

# NPA

August 2016  
www.taegutec.com



New Product Announcement No. 2016-12



## T-BURST

HIGH PRESSURE

### A New T-BURST Holder for Swiss Turning Applications



 **TaeguTec**  
Member IMC Group

## KEY POINT

**TaeguTec is pleased to introduce a new addition to the T-BURST high pressure coolant holder for swiss turning applications.**

The **T-BURST** holder for swiss turning applications, as with the current **T-BURST** holder, applies high pressure coolant from dual holes directly between the metal chip and the insert's rake face for optimum chip control, extended tool life as well as increased productivity through higher cutting speeds and feed rates.

It is capable of handling coolant pressure up to 140 [bar] maximum and is designed to machine miniature products generally found in the automotive, medical and aerospace sectors. The new **T-BURST** holder is ideally suited for machining difficult-to-cut materials such as stainless steel, titanium, inconel and other heat resistant alloys.

For added convenience, a simple coupling (one-touch exchange) system has been introduced. The hose connecting the machine to the holder can be easily and quickly attached or detached for replacement.

The coupling system's hoses are available in two lengths: 200 mm and 300 mm depending on the machine's specifications.

### Features

- Excellent chip control
- Increased tool life under the same cutting conditions
- Better productivity in higher cutting conditions because both the cutting speed and feed rate are increased
- Simplified hose set coupling system for quick holder set-up



## Swiss turn T-BURST holder components

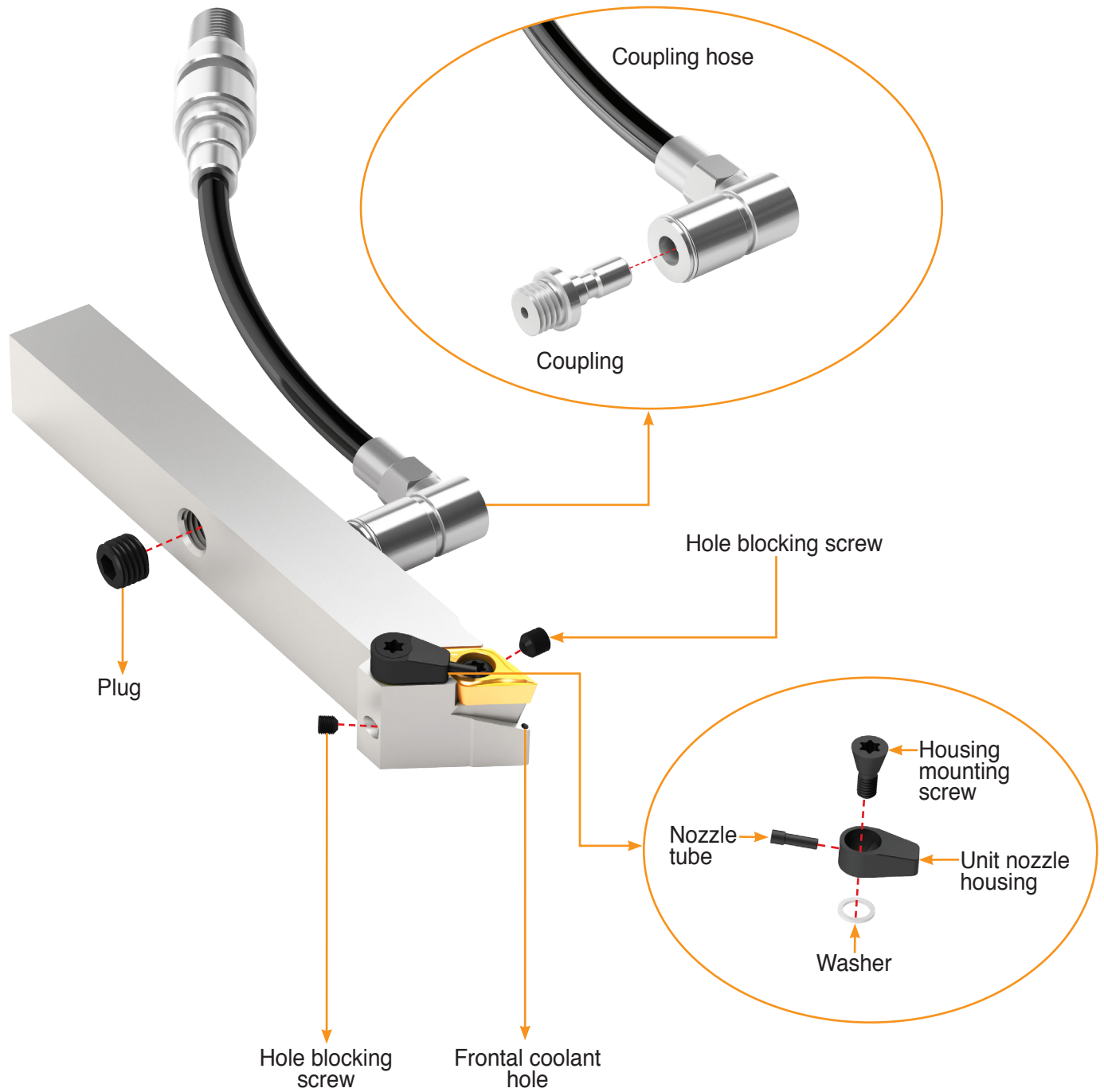

## New Product Announcement No. 2016-12

**T-BURST**  
HIGH PRESSURE

### T-BURST vs normal pressure tool life test results

Workpiece material	Stainless steel
Operation	Ext, Wet
Test coolant pressure	69 bar

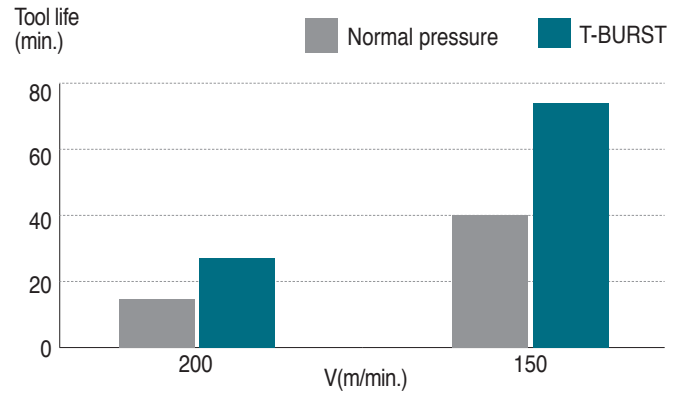

### T-BURST vs normal pressure chip breaking test results

V=200m/min.

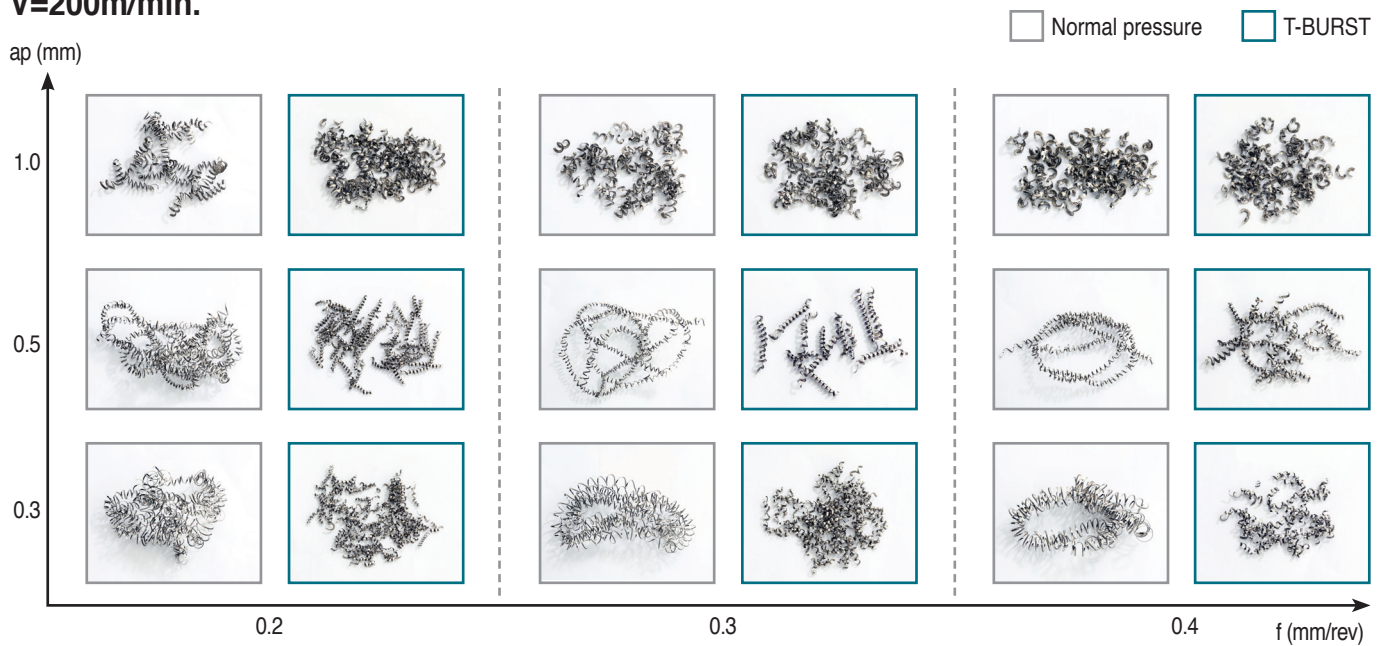

#### Availability

In stock

#### Price

Available in the GAL system

Sincerely,  
**TaeguTec**

**Park Hong-sik**  
Non-Rotating Product Manager

Sincerely,  
**TaeguTec**

**Bae Dae-wi**  
Turning Product Manager

## New Product Announcement No. 2016-12



### Case study 1 (Auto part)

		Competitor	TaeguTec
Component		Mission (core)	
Workpiece material		Steel magnetic iron	
Tool		High pressure holder	SDJCR 1616 K11-SH-TB
Insert		DCGT 110304	DCGT 11T304 SA
Grade		PVD coating grade	TT9020
Cutting speed	V (m/min)	141	141
Feed rate	f (mm/rev)	0.06	0.06
Depth of cut	ap (mm)	0.3	0.3
Coolant		High pressure internal coolant	High pressure internal coolant
Tool life (pcs/insert)		200	400

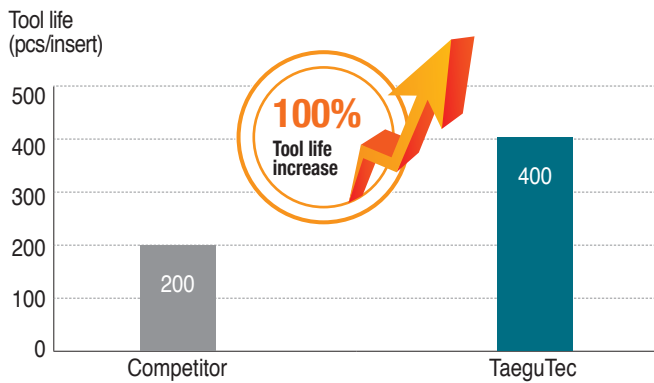

### Case study 2 (Auto part)

		Competitor	TaeguTec
Component		Mission (Core)	
Workpiece material		Steel magnetic iron	
Tool		Conventional holder	SDJCR 1616 K11-SH-TB
Insert		DCGT 11T304	DCGT 11T304 SA
Grade		PVD coating grade	TT9020
Coolant		High pressure external coolant	High pressure internal coolant
Tool life (pcs/insert)		100	400

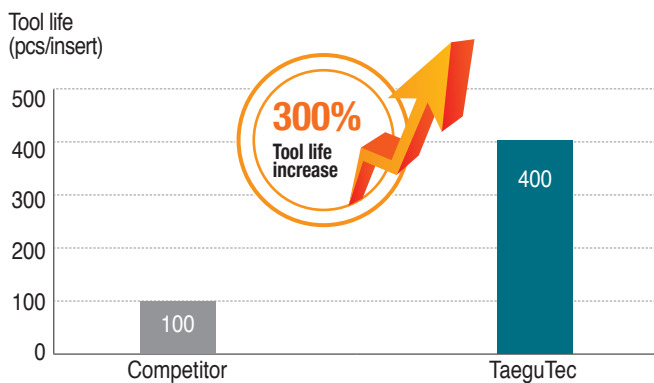

## New Product Announcement No. 2016-12



### Case study 3 (Auto part)

		Competitor	TaeguTec
Component		Mission (core)	
Workpiece material		Steel magnetic iron	
Tool		High pressure holder	SVJBR 1616 K11-SH-TB
Insert		VCGT 110302	VCGT 110302 SA
Grade		PVD coating grade	TT9020
Cutting speed	V (m/min)	226	226
Feed rate	f (mm/rev)	0.07	0.07
Depth of cut	ap (mm)	0.05-0.1	0.05-0.1
Coolant		High pressure internal coolant	High pressure internal coolant
Tool life (pcs/insert)		200	400

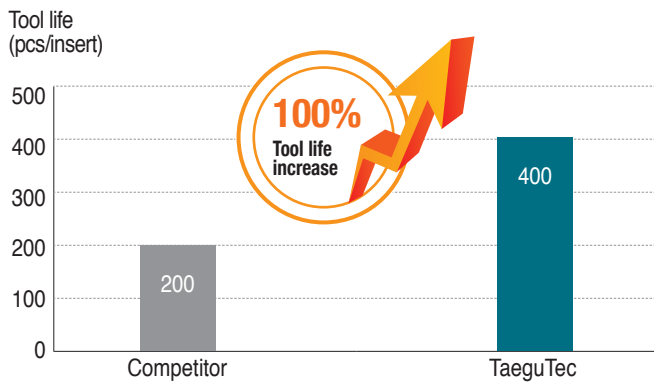

### Case study 4 (Medical part)

		Competitor	TaeguTec
Component		Abutment	
Workpiece material		Chrome cobalt molybden steel	
Tool		Conventional holder	SVJCR 1616 K11-SH-TB
Insert		VCGT 110302	VCGT 11T302 SA
Grade		PVD coating grade	TT9020
Cutting speed	V (m/min)	62	62
Feed rate	f (mm/rev)	0.04	0.04
Depth of cut	ap (mm)	0.1	0.1
Coolant		High pressure external coolant	High pressure internal coolant
Tool life (pcs/insert)		100	200

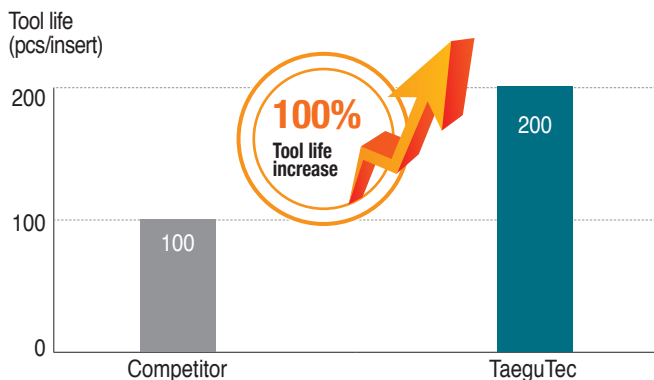

## New Product Announcement No. 2016-12



### SCACR/L-SH-TB

#### T-BURST holder

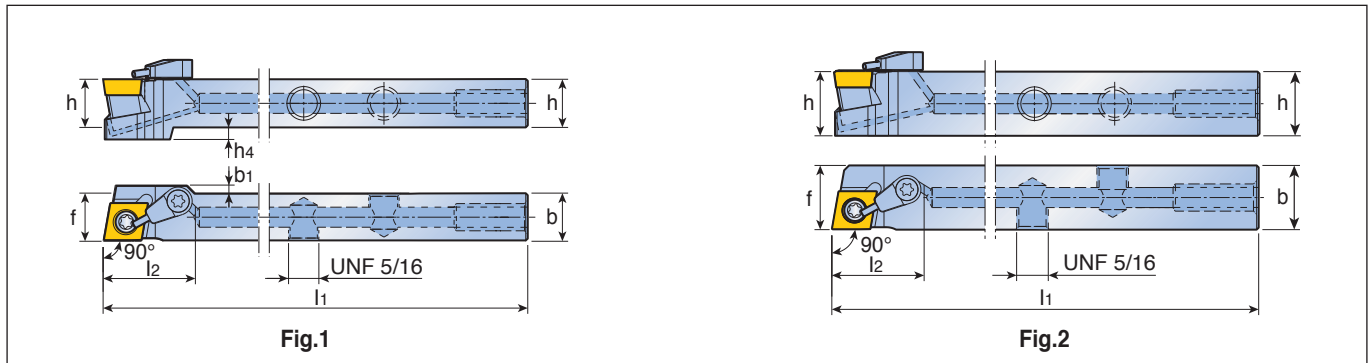

Approach angle	Designation	Dimension (mm)							Fig.	Insert
		h	b	l1	l2	f	b1	h4		
90°	<b>SCACR/L 1212 K09-SH-TB</b>	12	12	125	23	12	2	3	1	CC...T 09T3...
	<b>1616 K09-SH-TB</b>	16	16	125	23	16	-	-	2	

#### Spare parts

Designation	Screw	Oil-supply unit	Plug1	Plug2	Wrench1	Wrench2
<b>SCACR/L...TB</b>	SO 350801	S-CU-TB	PLG 5/16 UNF	SS M3x0.5x3-NL	T 15	L-W 5/32

### SCLCR/L-SH-TB

#### T-BURST holder

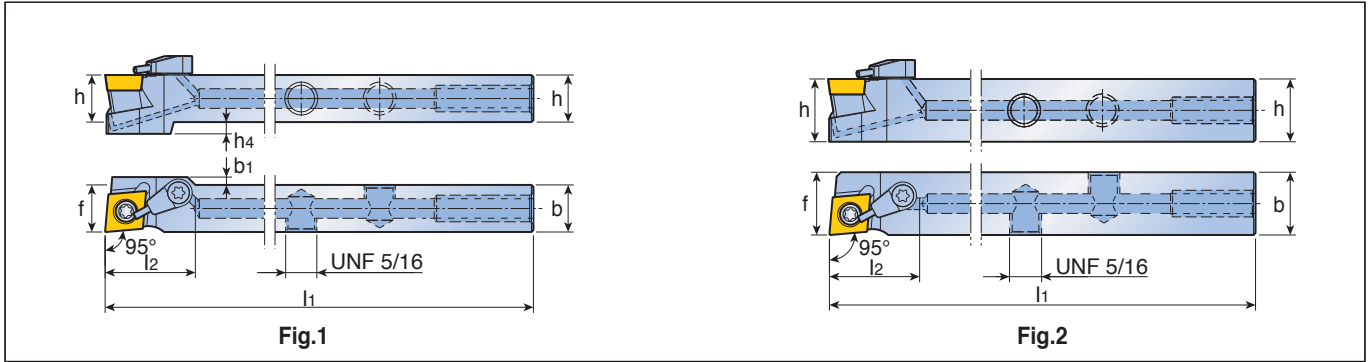

Approach angle	Designation	Dimension (mm)							Fig.	Insert
		h	b	l <sub>1</sub>	l <sub>2</sub>	f	b <sub>1</sub>	h <sub>4</sub>		
95°	<b>SCLCR/L 1212 K09-SH-TB</b>	12	12	125	23	12	2	3	1	CC...T 09T3...
	<b>1616 K09-SH-TB</b>	16	16	125	23	16	-	-	2	

#### Spare parts

Designation	Screw	Oil-supply unit	Plug1	Plug2	Wrench1	Wrench2
<b>SCLCR/L...TB</b>	SO 350801	S-CU-TB	PLG 5/16 UNF	SS M3x0.5x3-NL	T 15	L-W 5/32



## New Product Announcement No. 2016-12



### SDJCR/L-SH-TB

T-BURST holder

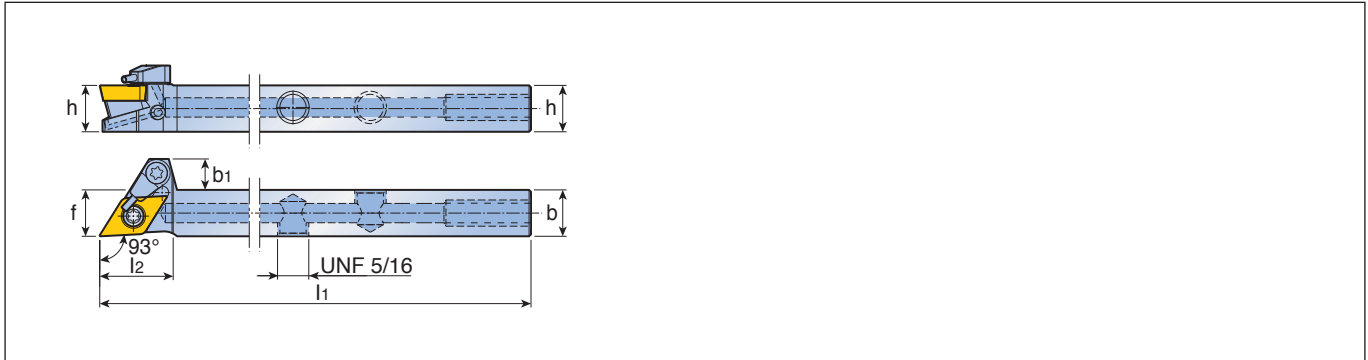

Approach angle	Designation	Dimension (mm)						Insert
		h	b	l <sub>1</sub>	l <sub>2</sub>	f	b <sub>1</sub>	
93°	<b>SDJCR/L 1212 K11-SH-TB</b>	12	12	125	19	12	8	DC...T 11T3...
	<b>1616 K11-SH-TB</b>	16	16	125	19	16	4	

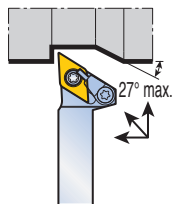

### Spare parts

Designation	Screw	Oil-supply unit	Plug1	Plug2	Plug3	Wrench1	Wrench2
<b>SDJCR/L...TB</b>	SO 350801	S-CU-TB	PLG 5/16 UNF	SS M4x0.7x4-NL	SS M3x0.5x3-NL	T 15	L-W 5/32

## New Product Announcement No. 2016-12



### SDNCN-SH-TB

#### T-BURST holder

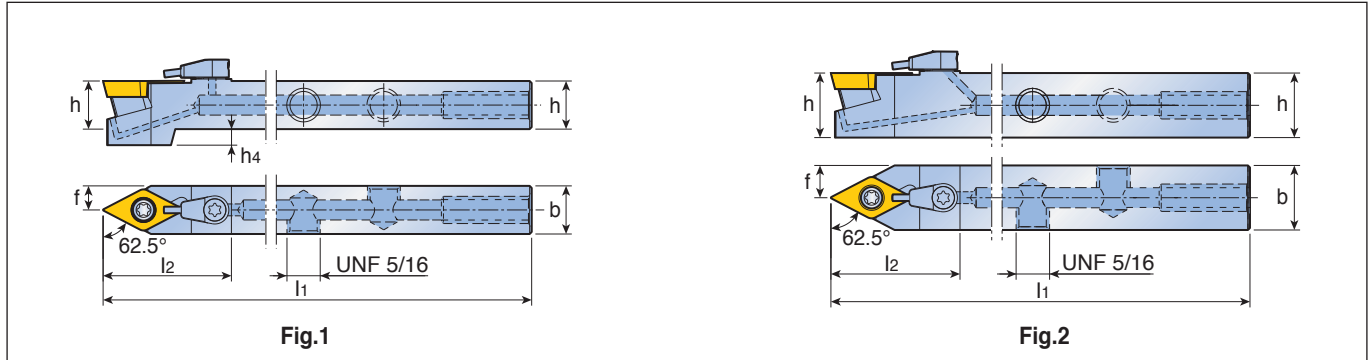

Approach angle	Designation	Dimension (mm)						Fig.	Insert
		h	b	l <sub>1</sub>	l <sub>2</sub>	f	h <sub>4</sub>		
62.5°	<b>SDNCN 1212 K11-SH-TB</b>	12	12	125	32	6	4	1	DC...T 11T3...
	<b>1616 K11-SH-TB</b>	16	16	125	32	8	-	2	

#### Spare parts

Designation	Screw	Oil-supply unit	Plug1	Plug2	Wrench1	Wrench2
<b>SDNCN...TB</b>	SO 35080I	S-CU-TB	PLG 5/16 UNF	SS M2.5x0.45x2.5 SH-TB	T 15	L-W 5/32

## New Product Announcement No. 2016-12



### STGCR/L-SH-TB



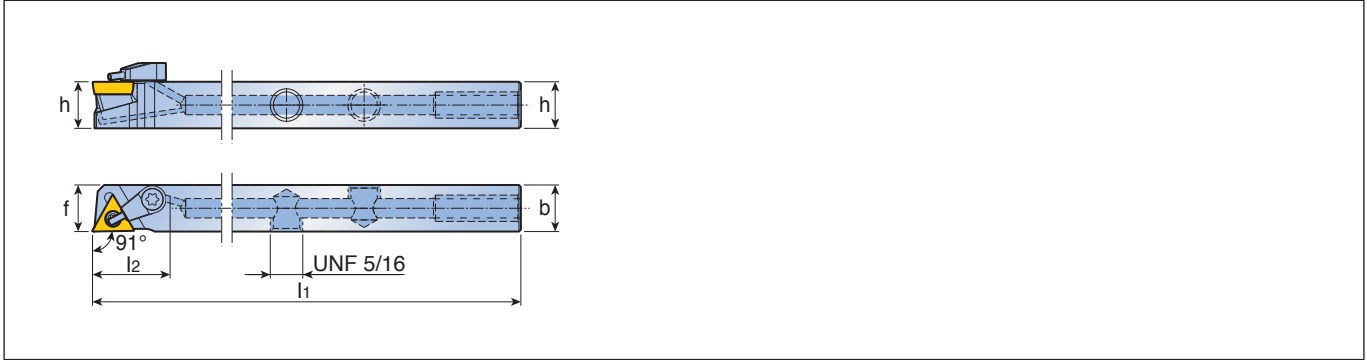

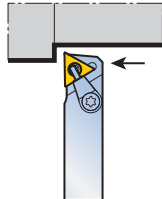

#### T-BURST holder



Approach angle	Designation	Dimension (mm)					Insert
		h	b	l1	l2	f	
<b>91°</b>	<b>STGCR/L 1212 K11-SH-TB</b>	12	12	125	20	12	TC...T 1103...
	<b>1616 K11-SH-TB</b>	16	16	125	20	16	



#### Spare parts

Designation	Screw	Oil-supply unit	Plug1	Plug2	Wrench1	Wrench2
<b>STGCR/L...TB</b>	 SO 250651	 S-CU-TB	 PLG 5/16 UNF	 SS M3x0.5x3-NL	 T 7	 L-W 5/32

### SVJBR/L-SH-TB

#### T-BURST holder

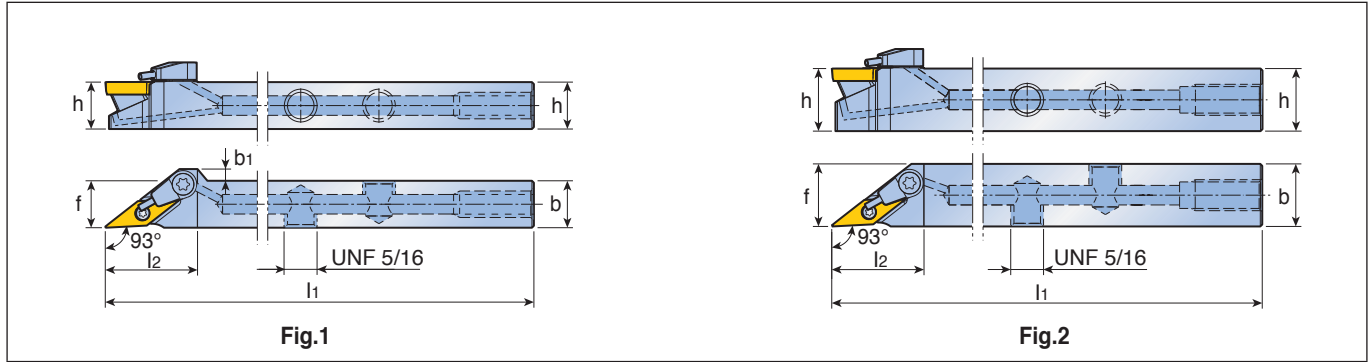

Approach angle	Designation	Dimension (mm)						Fig.	Insert
		h	b	l <sub>1</sub>	l <sub>2</sub>	f	b <sub>1</sub>		
93°	SVJBR/L 1212 K11-SH-TB	12	12	125	23.6	12	3	1	VB...T 1103...
	1616 K11-SH-TB	16	16	125	23.6	16	-	2	

#### Spare parts

Designation	Screw	Oil-supply unit	Plug1	Plug2	Wrench1	Wrench2
SVJBR/L...TB	SO 25065I	S-CU-TB	PLG 5/16 UNF	SS M3X0.5X3-NL	T 7	L-W 5/32

## New Product Announcement No. 2016-12



### SVJCR/L-SH-TB

#### T-BURST holder

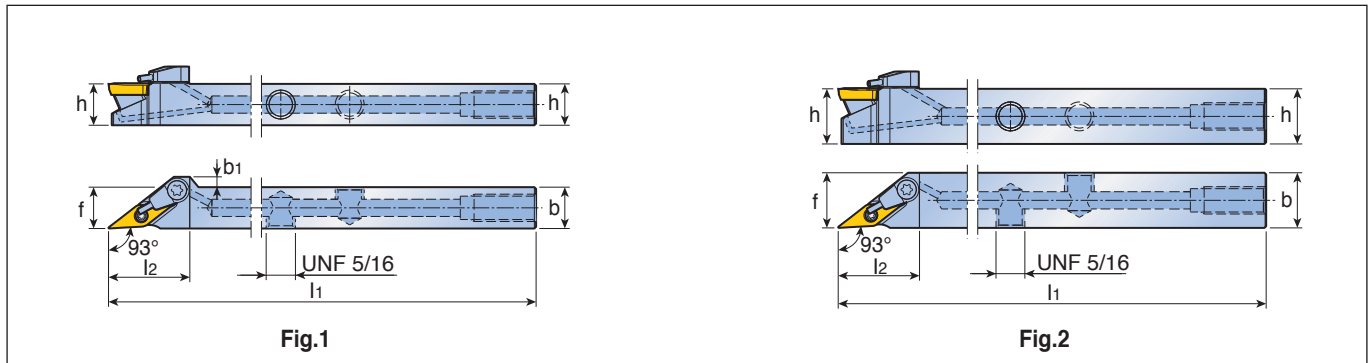

Approach angle	Designation	Dimension (mm)						Fig.	Insert
		h	b	l <sub>1</sub>	l <sub>2</sub>	f	b <sub>1</sub>		
93°	<b>SVJCR/L 1212 K11-SH-TB</b>	12	12	125	23.6	12	3	1	VC...T 1103...
	<b>1616 K11-SH-TB</b>	16	16	125	23.6	16	-	2	

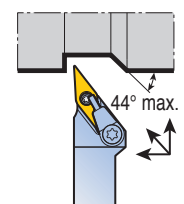

#### Spare parts

Designation	Screw	Oil-supply unit	Plug1	Plug2	Wrench1	Wrench2
<b>SVJCR/L...TB</b>	SO 250651	S-CU-TB	PLG 5/16 UNF	SS M3X0.5X3-NL	T 7	L-W 5/32

## New Product Announcement No. 2016-12



### SVVBN-SH-TB

#### T-BURST holder

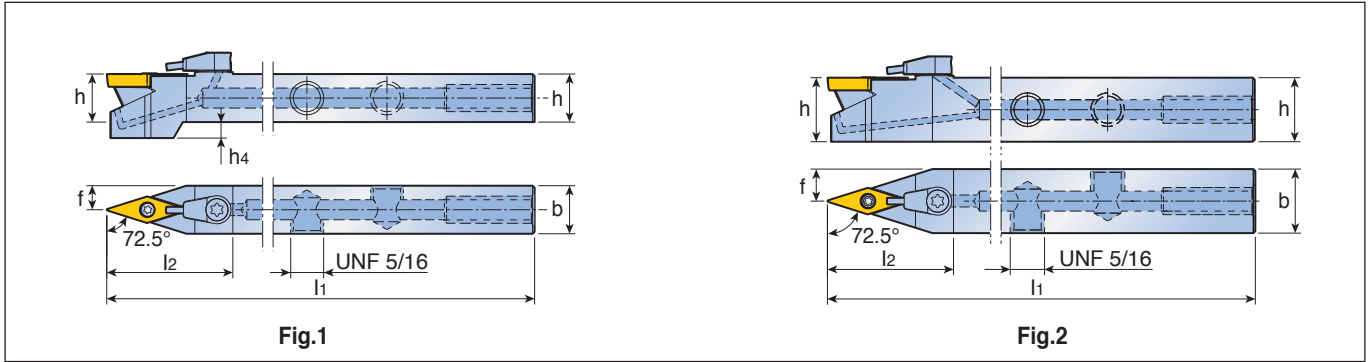

Approach angle	Designation	Dimension (mm)						Fig.	Insert
		h	b	l <sub>1</sub>	l <sub>2</sub>	f	h <sub>4</sub>		
72.5°	<b>SVVBN 1212 K11-SH-TB</b>	12	12	125	31.5	6	4	1	VB...T 1103...
	<b>1616 K11-SH-TB</b>	16	16	125	31.5	8	-	2	

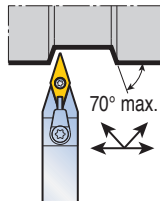

#### Spare parts

Designation	Screw	Oil-supply unit	Plug1	Plug2	Wrench1	Wrench2
<b>SVVBN...TB</b>	SO 25065I	S-CU-TB	PLG 5/16 UNF	SS M2.5X0.45X2.5 SH-TB	T 7	L-W 5/32

## New Product Announcement No. 2016-12



### Components

#### Hose

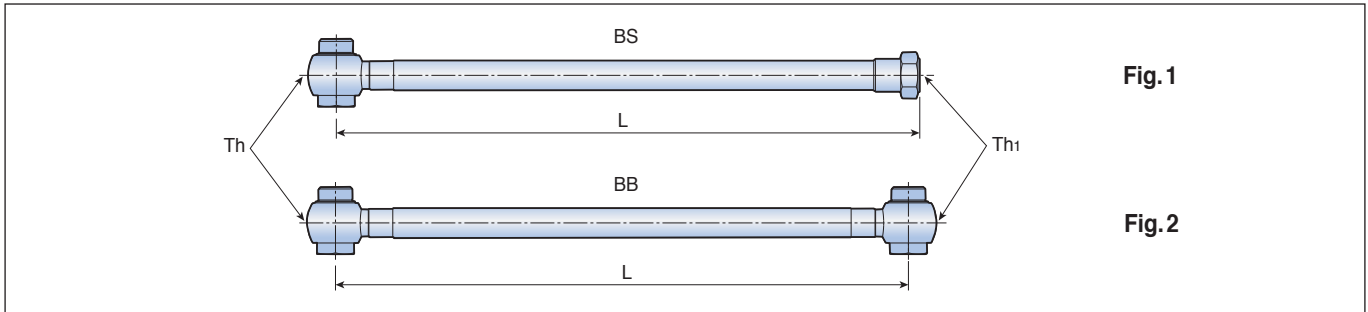

Designation	Dimension				Fig.
	L(mm)	Th	Th1	Max.pressure(Bar)	
<b>TB HOSE G1/8-7/16-200BS</b>	200	G1/8"-28 BSPP	7/16"-20 UNF (Flare 37°)	260	1
<b>G1/8-7/16-250BS</b>	250	G1/8"-28 BSPP	7/16"-20 UNF (Flare 37°)	260	1
<b>G1/8-G1/8-200BB</b>	200	G1/8"-28 BSPP	G1/8"-28 BSPP	260	2
<b>G1/8-G1/8-250BB</b>	250	G1/8"-28 BSPP	G1/8"-28 BSPP	260	2
<b>5/16-7/16-200BS</b>	200	5/16"-24 UNF	7/16"-20 UNF (Flare 37°)	200	1
<b>5/16-G1/8-200BS</b>	200	5/16"-24 UNF	G1/8"-28 BSPP	200	1

• Hose is ordered separately

#### Adapter

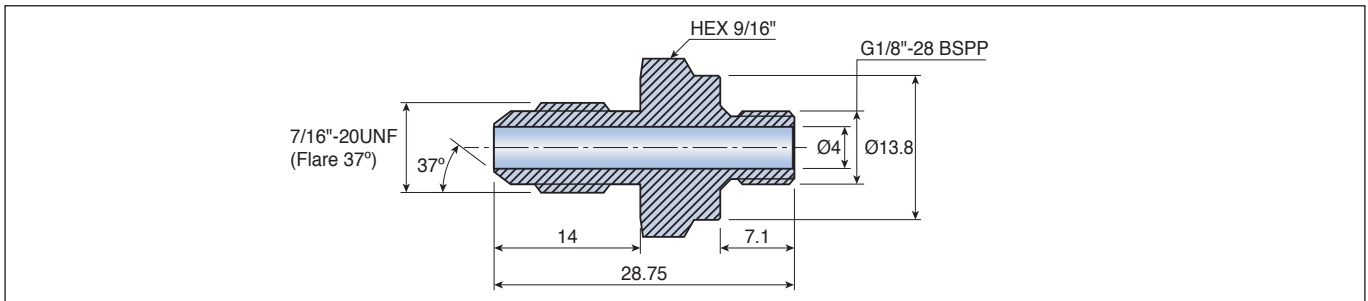

Designation
<b>TB NIPPLE G1/8-7/16 UNF</b>

• Adapter is ordered separately

#### Seal washer

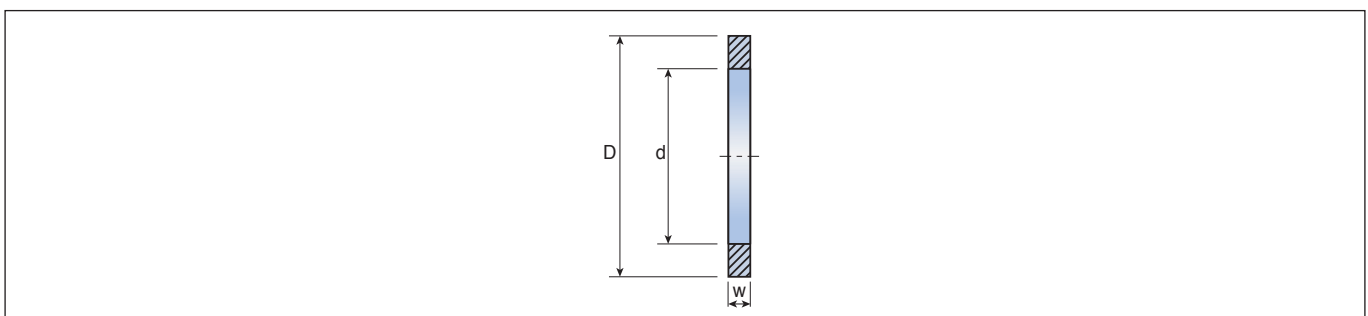

Designation	Dimension (mm)		
	D	d	w
<b>TB COPPER SEAL 1/8"</b>	15	10	1
<b>SEAL 5/16"</b>	12	8	1

• Seal washer is ordered separately

## New Product Announcement No. 2016-12



### Components

#### Connector

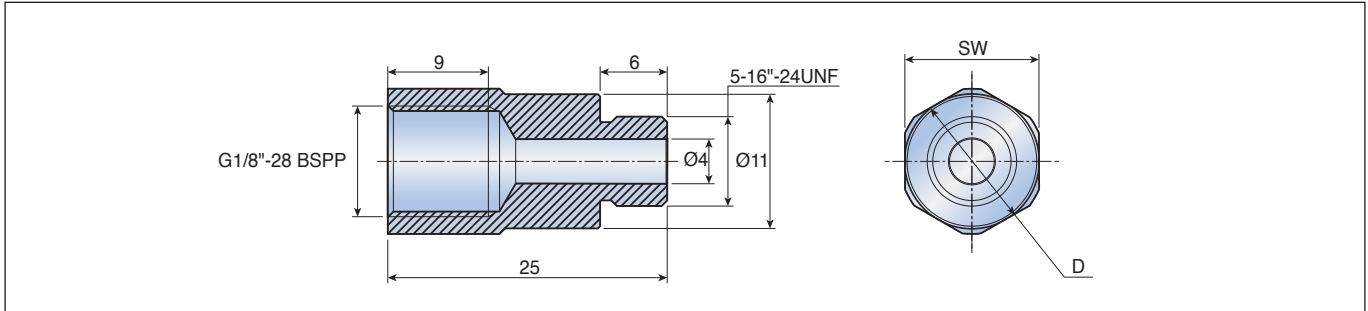

Designation	Dimension (mm)	
	D	SW
<b>TB CONECTOR 5/16"-G1/8"</b>	13	12
<b>5/16"-G1/8"-12</b>	12	11

• Connector is ordered separately

#### Coupling system

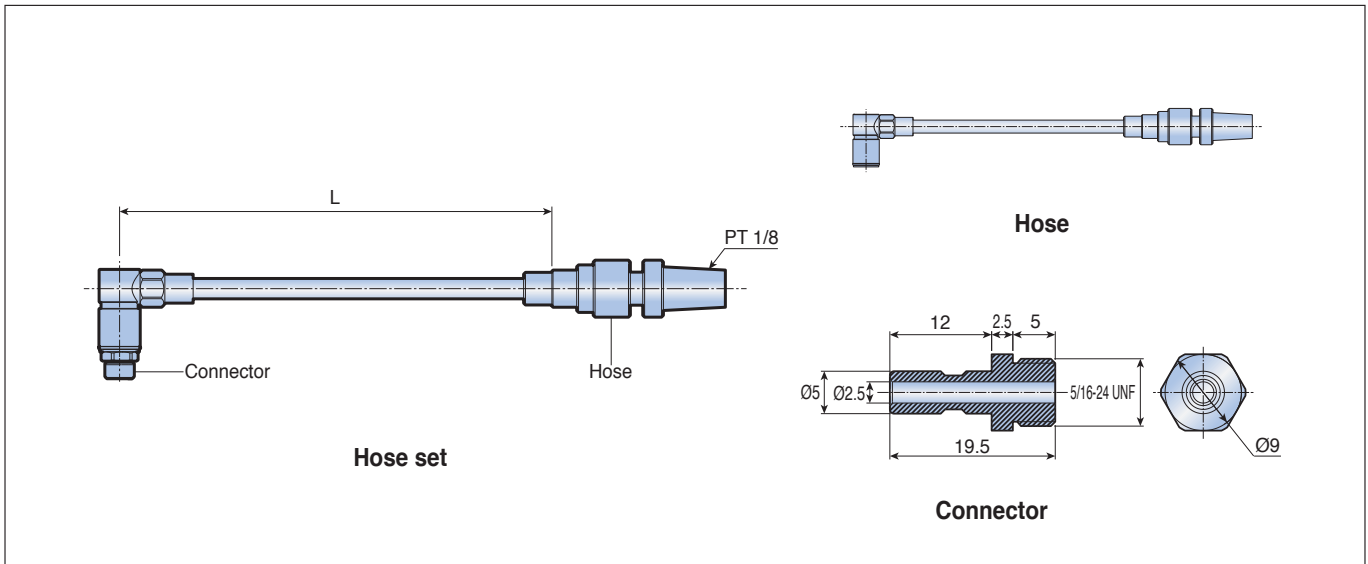

Components	Designation	Dimension	
		L (mm)	Maximum Pressure (Bar)
<b>Hose set</b>	<b>S-TB HOSE R1/8-COUPLE-200</b>	200	140
	<b>R1/8-COUPLE-300</b>	300	140
<b>Hose</b>	<b>TB HOSE R1/8-COUPLE-200</b>	200	140
	<b>R1/8-COUPLE-300</b>	300	140
<b>Connector</b>	<b>TB CONNECTOR 5/16-COUPLE</b>	-	-

• Hose set, hose and connector are ordered separately



## How to connect coupling system

### 1. Coupling connection

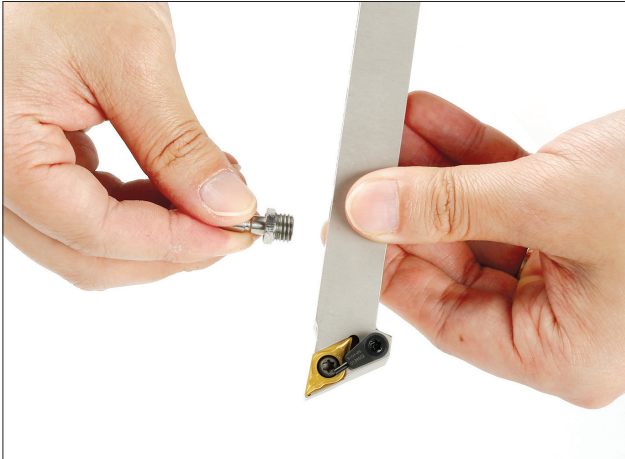

### 2. Connection between hose and coupling

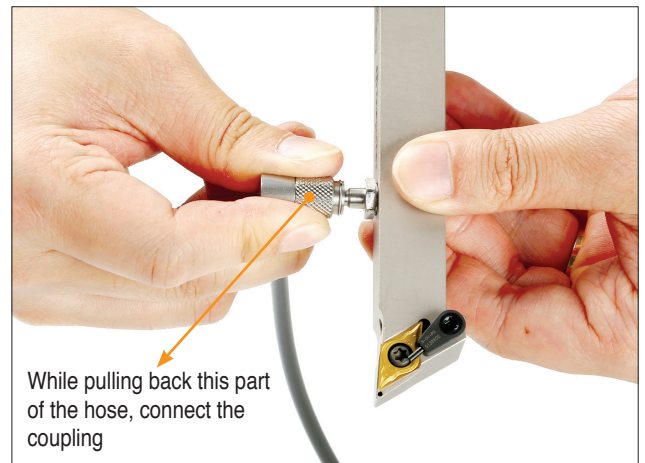
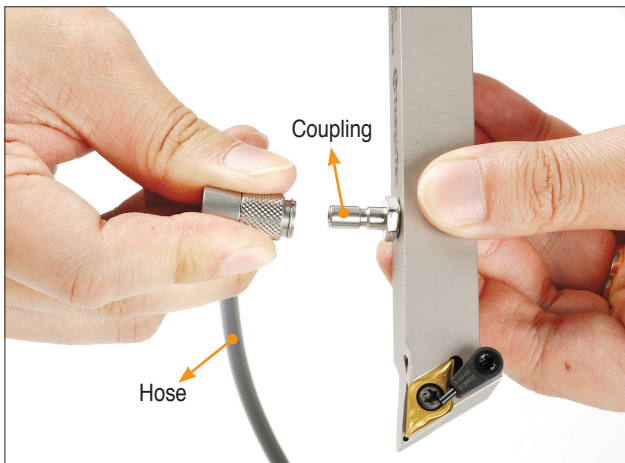

### 3. Connection completed

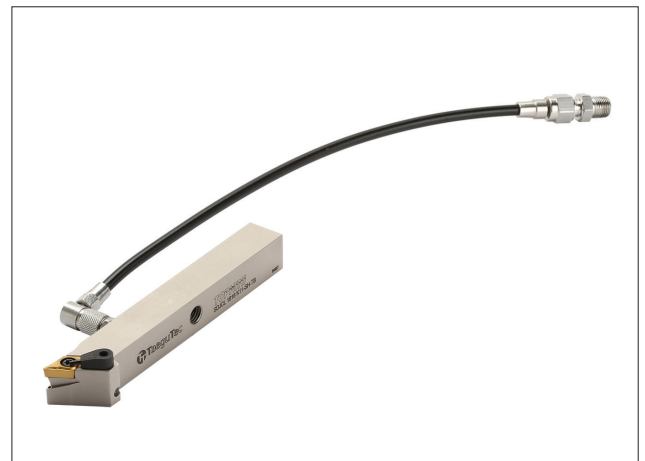
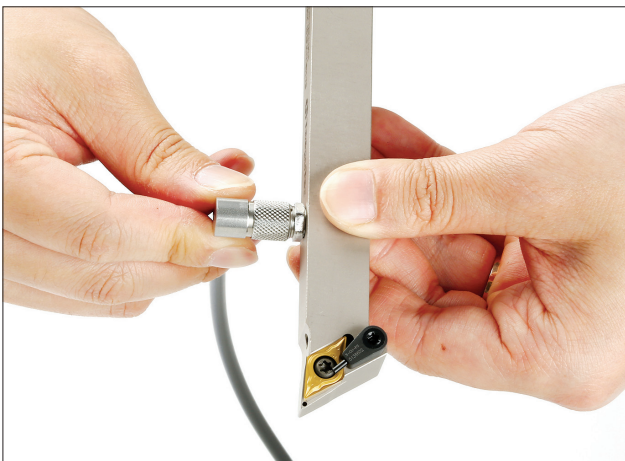

\* To disconnect from the holder, proceed in the reverse order as shown above.