

# PARTING & GROOVING



[Contents](#)

# PARTING & GROOVING



## contents

### Tool Selection Guide

Holder Selection Guide	B4
Insert Selection Guide	B10

### Grades

B12

### Toolholders

Blade Designation System	B14
Holder Designation System	B15
T-CLAMP Holder	B16
T-GROOVE Holder	B56
TOPCUT Holder	B57
QUADRUSH Holder	B59

- For more technical information, see TaeguTec technical guide part TB

## Guide to Icons



➤ Holder Page



➤ Sleeve Page



➤ Insert Page



➤ Components Page



➤ Cutting Condition Page



➤ Technical Guide Page



### Inserts and Solid Bars

Insert Designation System	B62
T-CLAMP Insert	B64
T-GROOVE Insert	B78
TOPMICRO Designation System	B79
TOPMICRO Sleeve and Solid Bar	B80
TOPCUT Designation System	B91
TOPCUT Insert	B92
QUADRUSH Designation System	B95
QUADRUSH Insert	B96
Tailor-made Designation System	B103
Tailor-made Insert	B104
<b>Recommended Cutting Conditions</b>	<b>B110</b>

---



---



---



---



---



---



---



---





# Tool Selection Guide

## Parting and grooving holder

Series			<b>T-CLAMP</b> <small>ULTRA PLUS</small>				
			TGB	TGB-MS	TGBR/L TGBR/L-DR/L	TGBFR/L	TGER/L
Pages			B16	B17	B18	B21	B22
Application	External	Parting		●	●	●	●
		Grooving		●	●	●	●
		Turning					
	Facing	Grooving					●
		Turning					
	Internal	Grooving					
		Turning					
	Profiling						
	Threading						
	Undercut						

# Tool Selection Guide

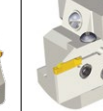

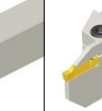
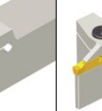
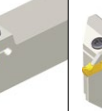







## Parting and grooving holder

T-CLAMP <small>ULTRA PLUS</small>		QUAD-RUSH	T-CLAMP <small>ULTRA PLUS</small>				
TCER/L	TCFR/L	TQCR/L	C-ADAPTER	TTER/L-SH	TTER/L-D	TTER/L	TTSER/L
							
B25	B26	B27	B30	B33	B34	B36	B38
●		●	●	●	●	●	○
●		●	●	●	●	●	●
●		○	●	●	●	●	●
	●		●				
	●		●				
●		○	●	●	●	●	○
●		○	●	●	●	●	○
			●				

● Recommended, ○ Suitable

# Tool Selection Guide









## Parting and grooving holder

Series			<b>T-CLAMP</b> <small>ULTRA PLUS</small>					
			<u>TGSFR/L</u>	<u>TGFR/L</u>	<u>TTFR/L</u>	<u>TTFR/L-RN</u>	<u>TGFPR/L</u>	
<b>Pages</b>			B39	B40	B41	B42	B44	
<b>Application</b>	External	Parting						
		Grooving		●	●			●
		Turning		●	○			○
	Facing	Grooving		○	●	●	●	●
		Turning		○	●	●	●	●
	Internal	Grooving						
		Turning						
	Profiling							
	Threading							
	Undercut							

# Tool Selection Guide

## Parting and grooving holder

**T-CLAMP**  
ULTRA PLUS











<u>TTFPR/L</u>	<u>TGIFR/L</u>	<u>TTFIR/L</u>	<u>TTIR/L</u>	<u>TTSIR/L</u>	<u>TGSIR/L</u>	<u>TGEUR/L</u>	<u>TGIUR/L</u>
							
B45	B46	B47	B48	B50	B51	B52	B53
●	●	●					
●	●	●					
			●	●	●		
			●	●	●		○
						●	●

● Recommended, ○ Suitable

Contents

# Tool Selection Guide

## Parting and grooving holder

Series			<b>T-CLAMP</b> <small>ULTRA PLUS</small>		<b>T-GROOVE</b>	<b>TOPCUT</b>	<b>QUAD-RUSH</b>	
			<u>TTER/L-15A</u>	<u>TGIUR/L-15A</u>	<u>TTLEN</u>	<u>TTVER/L</u> <u>TTVBR/L</u>	<u>TQHR/L</u> <u>TQHPR/L</u>	
<b>Pages</b>			B54	B55	B56	B57	B59	
<b>Application</b>	External	Parting					●	●
		Grooving				●	●	●
		Turning		●	●		●	○
	Facing	Grooving						
		Turning						
	Internal	Grooving						
		Turning						
	Profiling		●	●			○	
	Threading					●	○	
	Undercut							

● Recommended, ○ Suitable

















# Tool Selection Guide

Internal application by diameter

Internal diameter (mm)	<i>TOPMICRO</i>	<i>TOPCAP</i>	TTSIR/L	TTIR/L
0				
0.6	↓			
1				
2				
3				
4				
5				
6				
7				
8				
9				
10				
11				
12		↓		
12.5				↓
13				
14				
15				
16				
17				
18				
19				
20				
21				
22				
23				
24				
25				↓
26				







# Tool Selection Guide

## Parting and grooving insert

			<b>T-CLAMP</b> <small>TURNING PLUS</small>					
			TDC TSC	TDJ TSJ	TDXU TDXT	TDT	TDT - RU TDT	
<b>Series</b>								
<b>Pages</b>			B64	B66	B68	B69	B71	
<b>Application</b>	External	Parting		●	●	○		
		Grooving		●	●	●	●	
		Turning				●	●	●
	Facing	Grooving		○	○	●	○	
		Turning				●	○	
	Internal	Grooving		○	○	●	○	
		Turning				●	○	
	Profiling							●
	Threading						○	
	Undercut						○	

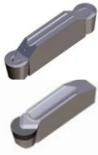
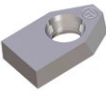
# Tool Selection Guide

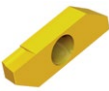

## Parting and grooving insert

<b>T-CLAMP</b> <small>ULTRA PLUS</small>				<b>T-GROOVE</b>	<b>TOPMICRO</b>	<b>TOPCUT</b>	<b>QUAD-RUSH</b>
<u>TDFT</u>	<u>TDIT</u>	<u>TDIM TDIP</u>	<u>TDA TSA</u>	<u>TGUX</u>	<u>MIN.</u>	<u>TV..</u>	<u>TQ..</u>
							
B73	B73	B75	B77	B78	B81	B92	B96
○	○	○				●	●
○	○	●		●		●	●
○	○	●	●			●	●
●		○					
●		○					
	●	●			●		
	●	●			●		
			●		●		○
					●	●	●
	○						

● Recommended, ○ Suitable

# Grades

## Parting and grooving grades

Grades	ISO	Characteristics & applications
 <b>TT6300</b> CVD coated	<b>K01</b> – <b>K15</b>	This grade has an extra thick CVD coating that guarantees excellent tool life especially when machining gray cast iron. Its surface has been treated after the coating process.
 <b>TT6080</b> PVD coated	<b>K05</b> – <b>K25</b> <b>H05</b> – <b>H25</b>	The latest PVD coating technology has been applied to substrate that has multi nano layers such as Multi Nano AlTiN/TiAlCrN/TiN. This ensures outstanding performance when machining ductile cast iron, as well as interrupted machining on gray cast iron. The surface has been treated after the coating process.
<b>TT5100</b> CVD coated	<b>P20</b> – <b>P35</b> <b>M20</b> – <b>M35</b>	A CVD coated grade for machining carbon steels, alloy steels and stainless steels with outstanding tool life
 <b>TT9080</b> PVD coated	<b>P20</b> – <b>P40</b> <b>M20</b> – <b>M40</b> <b>S20</b> – <b>S40</b>	In order to improve machining performance of the existing TT9030 grade for general turning, grooving profiling and parting applications on carbon steel, alloy steel and stainless steel, TaeguTec has applied the latest coating technology to the existing sub micron substrate. This grade has better wear resistance than the TT9030 while maintaining the same toughness levels.
<b>TT7220</b> PVD coated	<b>P25</b> – <b>P45</b> <b>M25</b> – <b>M45</b>	A PVD coated grade for machining carbon steel and alloy steel
<b>TT8020</b> PVD coated	<b>P30</b> – <b>P50</b> <b>M30</b> – <b>M50</b> <b>S30</b> – <b>S50</b>	TaeguTec's toughest PVD grade for severely interrupted cutting, stainless steel and exotic alloy machining
<b>CT3000</b> Cermet	<b>P10</b> – <b>P20</b> <b>M10</b> – <b>M20</b> <b>K10</b> – <b>K20</b>	A tough new reinforced cermet grade with excellent wear resistance. Recommended for grooving, parting & turning alloy steels and stainless steels with good surface quality and long tool life

# Parting & Grooving Toolholders



# Blade Designation System



## 1 TaeguTec

### 2 Application type

G	Grooving
T	Turning

### 3 Holer type

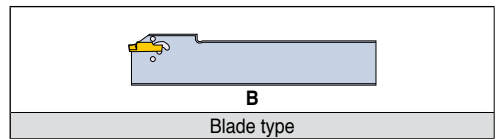

### 4 Machining type

F	Face grooving
---	---------------

### 5 Hand of holder

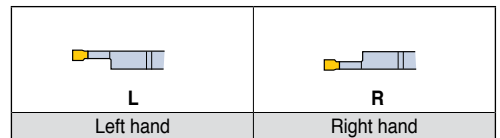

### 6 Blade height

	<p><b>26</b> = 26.0 mm</p> <p><b>32</b> = 32.0 mm</p> <p><b>45</b> = 45.0 mm</p> <p><b>52</b> = 52.0 mm</p>
--	---

### 7 Insert size

	<p><b>2</b> = 2.0 mm</p> <p><b>3</b> = 3.0 mm</p> <p><b>4</b> = 4.0 mm</p> <p><b>5</b> = 5.0 mm</p> <p><b>6</b> = 6.0 mm</p>
--	--

### 8 Special code

S	Single type blade
MS	Blade for multi spindle machine
CL	Screw clamping

# Holder Designation System

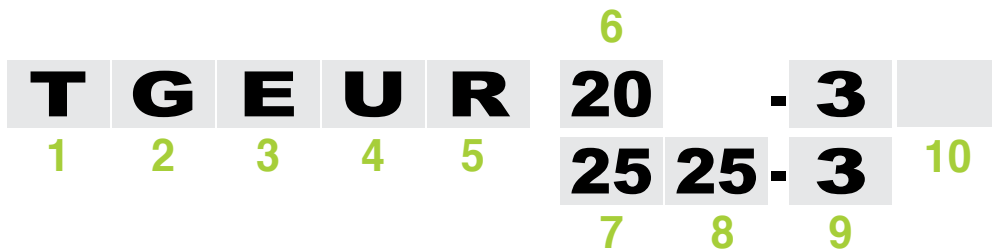

## 1 TaeguTec

### 2 Application type

**G** Grooving  
**T** Turning

### 3 Machining type

**E** External machining  
**I** Internal machining  
**F** Face machining

### 4 Holder shape

**U** Undercutting  
**P** Perpendicular type

### 5 Hand of holder

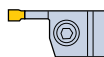

**L**

Left hand

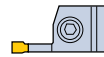

**R**

Right hand

### 6 Shank diameter

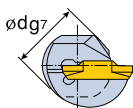

10, 12, 16, 20, 25  
32, 40, 50, etc

### 7 Shank height

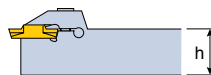

10, 12, 16, 20, 25  
32, 40, etc

### 8 Shank width



10, 12, 16, 20, 25, 32, 40, etc

### 9 Insert size

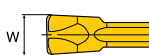

2, 3, 4, 5, 6, 8, 10

### 10 Special code

**C** With coolant hole  
**T**  Overhang length  
**SH** Holder for swiss automatics  
**RN** Renewed type holder

## Blades for parting and deep grooving

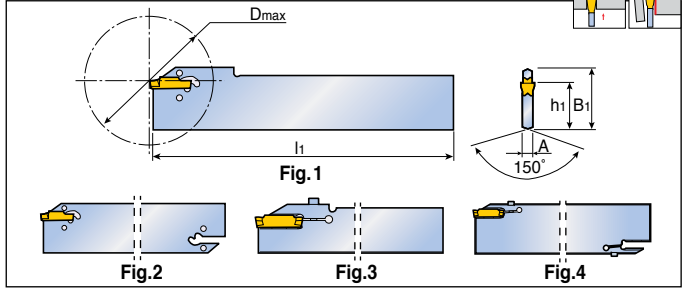
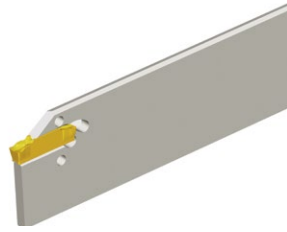

Designation	Insert seat size	Dimension (mm)						Block	Insert
		B1	li	h1	A	Dmax	Fig.		
<b>TGB 26-1.4S<sup>(1)</sup></b>	1	26	150	21.4	1.0 <sup>(2)</sup>	26	1	TTBN/U...26	TDC / J / T TDXU / XT
<b>26-2S<sup>(1)</sup></b>	2	26	150	21.4	1.8 <sup>(2)</sup>	40	1	TTBN/U...26	
<b>26-3S<sup>(1)</sup></b>	3	26	150	21.4	2.4	50	1	TTBN/U...26	TSC / J B64-B73
<b>26-4S<sup>(1)</sup></b>	4	26	150	21.4	3.2	80	1	TTBN/U...26	
<b>32-1.4</b>	1	32	150	24.9	1.0 <sup>(2)</sup>	26	2	TTBN/U...32	
<b>32-2</b>	2	32	150	24.9	1.8 <sup>(2)</sup>	50	2	TTBN/U...32	
<b>32-3</b>	3	32	150	24.9	2.4	100	2	TTBN/U...32	
<b>32-4</b>	4	32	150	24.9	3.2	100	2	TTBN/U...32	
<b>32-5</b>	5	32	150	24.9	4.0	120	2	TTBN/U...32	
<b>32-6</b>	6	32	150	24.9	5.2	120	2	TTBN/U...32	
<b>45-4</b>	4	45	150	38.1	3.2	120	2	TTBN/U...45	
<b>32-8S-CL<sup>(1)</sup></b>	8	32	150	24.9	6.2	80	3	TTBN/U...32	
<b>52-8-CL</b>	8	52	250	45.2	6.8	200	4	TTBN/U...52	

- <sup>(1)</sup> Single ended blade
- <sup>(2)</sup> Thickness at DOC area only. Overall thickness is 2.4mm

## Spare parts

Designation	Extractor	Screw	Wrench	
<b>TGB 26-1.4S / 32-1.4</b>	EDG-23B	-	-	
<b>TGB 26 / 32 / 45</b>	EDG-33B	-	-	
<b>TGB 32-8S-CL</b>	-	SH M4x0.7x20-MO	L-W3	
<b>TGB 52-8-CL</b>	-	SH M4x0.7x20-MO	L-W3	

Components • Extractor should be ordered separately





## Blades for multi-spindle machines replacement for HSS and brazed tools

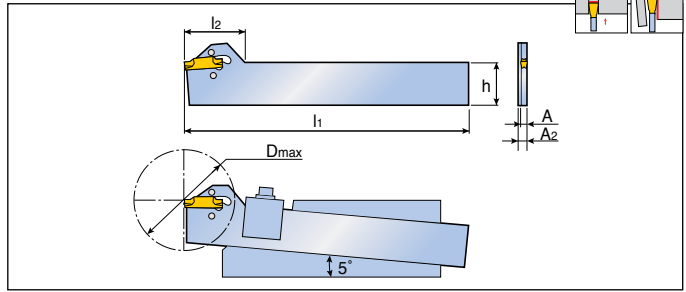
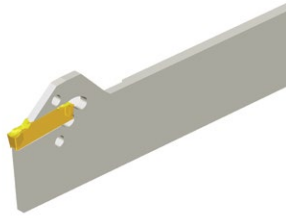

Designation	Insert seat size	Dimension (mm)						Insert
		h	l1	l2	A	A2	Dmax	
<b>TGB 5-22-2-MS</b>	2	22.2	150	32	1.8	3.2	42	TDC / J / T
<b>5-22-3-MS</b>	3	22.2	150	32	2.4	3.2	60	TDXU / XT
<b>5-22-4-MS</b>	4	22.2	150	32	3.2	3.2	80	TSC / J
								B64-B73

## Spare parts

Designation	Extractor			
<b>TGB-MS</b>	EDG-33B			

**Components** • Extractor should be ordered separately



## Reinforced blades for parting and deep grooving

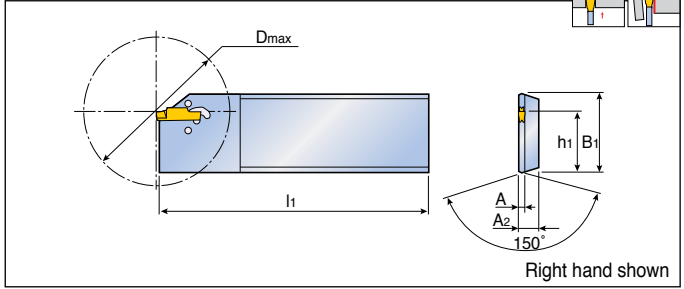
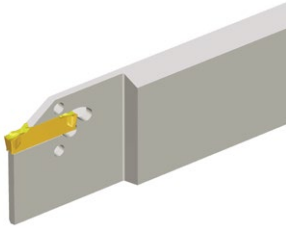

Designation	Insert seat size	Dimension (mm)						Block	Insert
		B1	l1	h1	A	A2	Dmax		
<b>TGBR/L 32T24-2</b>	2	32	110	24.9	1.8	8.0	42	TTBN/U..-32	TDC / J / T
<b>32T33-3</b>	3	32	110	24.9	2.4	8.0	60	TTBN/U..-32	TDXU / XT
<b>32T41-4</b>	4	32	110	24.9	3.2	10.0	80	TTBN/U..-32	TSC / J
									B64-B73

## Spare parts

Designation	Extractor			
<b>TGBR/L</b>	EDG-33B			

Components • Extractor should be ordered separately



## Reinforced type blades with screw clamping

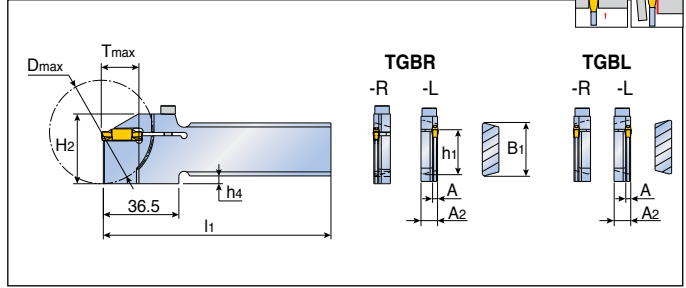
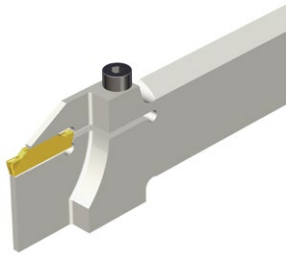

Designation	Insert seat size	Dimension (mm)									Block	Insert
		B1	A	A2	l1	h1	H2	h4	Tmax	Dmax		
<b>TGBR 26-2-D50R</b> <sup>(1)</sup>	2	26	1.8	8	110	21.4	33.7	3.6	18	50	TTBN/U...26	TDC / J / T TDXU / XT TSC / J B64-B73
<b>26-2-D50L</b> <sup>(2)</sup>	2	26	1.8	8	110	21.4	33.7	3.6	18	50	TTBN/U...26	
<b>TGBL 26-2-D50R</b> <sup>(2)</sup>	2	26	1.8	8	110	21.4	33.7	3.6	18	50	TTBN/U...26	
<b>26-2-D50L</b> <sup>(1)</sup>	2	26	1.8	8	110	21.4	33.7	3.6	18	50	TTBN/U...26	
<b>TGBR 26-3-D50R</b> <sup>(1)</sup>	3	26	2.4	8	110	21.4	33.7	3.6	18	50	TTBN/U...26	
<b>26-3-D50L</b> <sup>(2)</sup>	3	26	2.4	8	110	21.4	33.7	3.6	18	50	TTBN/U...26	
<b>TGBL 26-3-D50R</b> <sup>(2)</sup>	3	26	2.4	8	110	21.4	33.7	3.6	18	50	TTBN/U...26	
<b>26-3-D50L</b> <sup>(1)</sup>	3	26	2.4	8	110	21.4	33.7	3.6	18	50	TTBN/U...26	
<b>TGBR 32-2-D50R</b> <sup>(3)</sup>	2	32	1.8	8	120	24.9	33.7	-	18	50	TTBN/U...32	
<b>32-2-D50L</b> <sup>(2)</sup>	2	32	1.8	8	120	24.9	33.7	-	18	50	TTBN/U...32	
<b>TGBL 32-2-D50R</b> <sup>(2)</sup>	2	32	1.8	8	120	24.9	33.7	-	18	50	TTBN/U...32	
<b>32-2-D50L</b> <sup>(3)</sup>	2	32	1.8	8	120	24.9	33.7	-	18	50	TTBN/U...32	
<b>TGBR 32-3-D50R</b> <sup>(3)</sup>	3	32	2.4	8	120	24.9	33.7	-	18	50	TTBN/U...32	
<b>32-3-D50L</b> <sup>(2)</sup>	3	32	2.4	8	120	24.9	33.7	-	18	50	TTBN/U...32	
<b>TGBL 32-3-D50R</b> <sup>(2)</sup>	3	32	2.4	8	120	24.9	33.7	-	18	50	TTBN/U...32	
<b>32-3-D50L</b> <sup>(3)</sup>	3	32	2.4	8	120	24.9	33.7	-	18	50	TTBN/U...32	

- <sup>(1)</sup> for Traub machines, model TNC 30, TNM 28, TNS 26/30/42/112, TNA 300, TNK 260
- <sup>(2)</sup> for Tornos Bechler, model Emco 2000/20, 2000/26
- <sup>(3)</sup> for Traub machines, model TNC 42/65, TNM 42/65, TNS 42/60/65, TNA 300/400

## Spare parts

Designation	Screw	Wrench		
	<b>TGBR/L -DR/L</b>	SH M4x0.7x16	L-W3	



# TGBR/L -TI-D..R/L

Reinforced type blades with screw clamping for traub and index machines

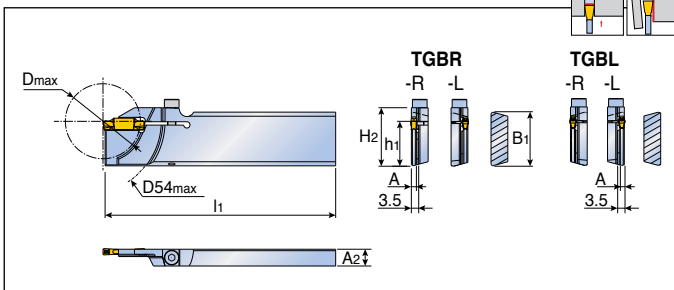
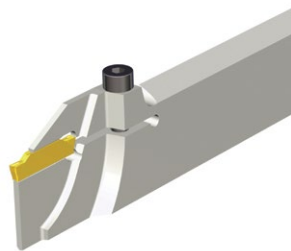

Designation	Insert seat size	Dimension (mm)							Block	Insert
		B1	A	A2	l1	h1	H2	Dmax		
TGBR/L 26-2TI-D36R	2	26	1.6	8	110	21.4	27.9	36	TTBN/U...-26	TDC / J / T
26-2TI-D36L	2	26	1.6	8	110	21.4	27.9	36	TTBN/U...-26	TDXU / XT
26-3TI-D36R	3	26	2.4	8	110	21.4	27.9	36	TTBN/U...-26	TSC / J
26-3TI-D36L	3	26	2.4	8	110	21.4	27.9	36	TTBN/U...-26	B64-B73

## Spare parts

Designation	Screw	Wrench		
TGBR/L -TI-DR/L	SH M4x0.7x16	L-W3		



## Blades for face grooving

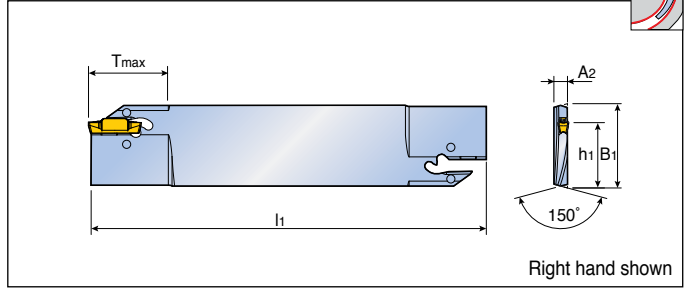

Designation	Insert seat size	Dimension (mm)							Block	Insert	
		B <sub>1</sub>	l <sub>1</sub>	h <sub>1</sub>	A <sub>2</sub>	T <sub>max</sub>	D <sub>min</sub>	D <sub>max</sub>			
<b>TGBFR/L 32T20-40-60-3</b>	3	32	150	24.9	5.2	20	40	60	TTBN/U...32	TDC / J / T TDXU / XT / FT TSC / J B64-B73	
<b>32T20-54-80-3</b>	3	32	150	24.9	5.2	20	54	80	TTBN/U...32		
<b>32T25-74-120-3</b>	3	32	150	24.9	5.2	25	74	120	TTBN/U...32		
<b>32T25-114-180-3</b>	3	32	150	24.9	5.2	25	114	180	TTBN/U...32		
<b>32T25-40-60-4</b>	4	32	150	24.9	5.2	25	40	60	TTBN/U...32		
<b>32T25-50-80-4</b>	4	32	150	24.9	5.2	25	50	80	TTBN/U...32		
<b>32T30-70-130-4</b>	4	32	150	24.9	5.2	30	70	130	TTBN/U...32		
<b>32T30-120-200-4</b>	4	32	150	24.9	5.2	30	120	200	TTBN/U...32		
<b>32T30-200-4</b>	4	32	150	24.9	5.2	30	200	∞	TTBN/U...32		
<b>32T32-60-95-5</b>	5	32	150	24.9	5.2	32	60	95	TTBN/U...32		
<b>32T35-85-140-5</b>	5	32	150	24.9	5.2	35	85	140	TTBN/U...32		
<b>32T35-130-250-5</b>	5	32	150	24.9	5.2	35	130	250	TTBN/U...32		
<b>32T35-250-5</b>	5	32	150	24.9	5.2	35	250	∞	TTBN/U...32		
<b>32T32-80-180-6</b>	6	32	150	24.9	5.2	32	80	180	TTBN/U...32		
<b>32T38-168-300-6</b>	6	32	150	24.9	5.2	38	168	300	TTBN/U...32		
<b>32T38-300-6</b>	6	32	150	24.9	5.2	38	300	∞	TTBN/U...32		

• Please check insert min. dia for face grooving [B43](#) page

## Spare parts

Designation	Extractor			
<b>TGBFR/L</b>	EDG-33B			



• Extractor should be ordered separately

TB31-TB32

## Parting and deep grooving

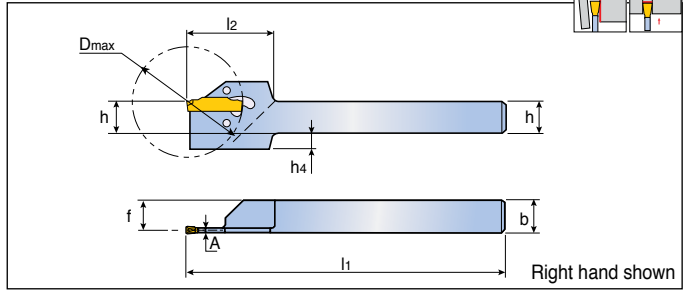
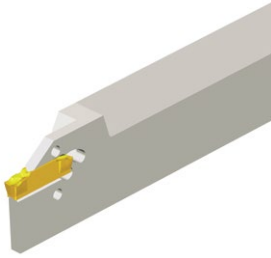

Designation	Insert seat size	Dimension (mm)							Dmax		Insert
		h	b	l <sub>1</sub>	f	l <sub>2</sub>	A	h <sub>4</sub>	TDJ/C	TSJ/C	
<b>TGER/L 2020-1.4T10</b>	1	20	20	125	19.5	31	1.0	-	20	20	TDC / J / T
<b>1010-2</b>	2	10	10	150	9.1	31	1.8	8	33	33	TDXU / XT
<b>1212-2</b>	2	12	12	150	11.1	31	1.8	6	35	35	TSC / J
<b>1616-2</b>	2	16	16	150	15.1	31	1.8	2	35	35	B64-B73
<b>2012-2</b>	2	20	12	150	11.1	31	1.8	-	35	35	
<b>2020-2</b>	2	20	20	150	19.1	31	1.8	-	35	35	
<b>1212-3</b>	3	12	12	150	10.8	31	2.4	6	38	40	
<b>1616-3</b>	3	16	16	150	14.8	31	2.4	2	38	45	
<b>2020-3</b>	3	20	20	125	18.8	31	2.4	-	38	45	
<b>2525-3</b>	3	25	25	150	23.8	31	2.4	-	38	45	
<b>2020-4</b>	4	20	20	125	18.4	33	3.2	-	38	55	
<b>2525-4</b>	4	25	25	150	23.4	33	3.2	-	38	55	

## Spare parts

Designation	Extractor			
<b>TGER/L....-1.4T10</b>	EDG-23B			
<b>TGER/L....-2</b>	EDG-33B			
<b>TGER/L....-3</b>	EDG-33B			
<b>TGER/L....-4</b>	EDG-33B			

Components • Extractor should be ordered separately



## Blocks for parting and deep grooving blades

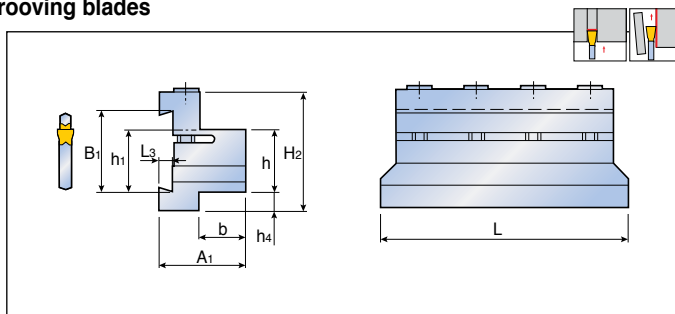

Designation	Dimension (mm)								
	B1	h1	h	h4	H2	L3	L	b	A1
<b>TTBN 16-26</b>	26	21.0	16	12	38	4.0	87	15	29
<b>20-26</b>	26	21.4	20	8	38	4.0	87	19	33
<b>25-26</b>	26	21.4	25	3	38	4.0	110	20	34
<b>20-32</b>	32	24.8	20	13	48	5.5	100	19	35
<b>25-32</b>	32	24.8	25	8	48	5.5	110	20	36
<b>32-32</b>	32	24.8	32	3	48	5.5	120	28	44
<b>25-45</b>	45	38.1	25	25	66	5.5	110	22	40
<b>32-45</b>	45	38.1	32	18	66	5.5	120	28	45
<b>40-52</b>	52	45.2	40	21	82	8.0	160	40	65

## Spare parts

Designation	Screw	Wrench		
<b>TTBN...26</b>	SH M6x1.0x25	L-W5		
<b>TTBN...32</b>	SH M6x1.0x30	L-W5		
<b>TTBN...45</b>	SH M6x1.0x40	L-W5		
<b>TTBN...52</b>	SH M8x1.25x45	L-W6		

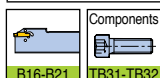

## Blocks for parting and deep grooving blades

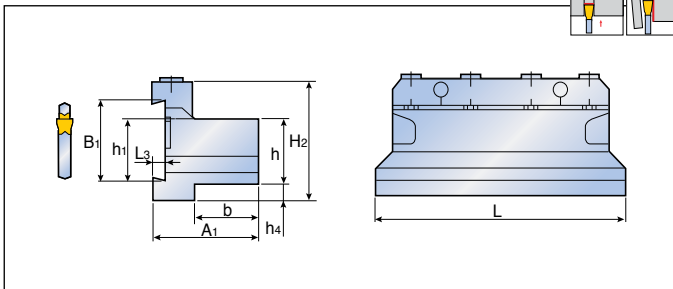
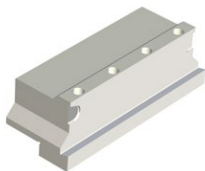

Designation	Dimension (mm)								
	B1	h1	h	h4	H2	L3	L	b	A1
<b>TTBU 20-26</b>	26	21.4	20	9	43	4.0	86	21	38
<b>25-26</b>	26	21.4	25	5	45	4.0	110	23	42
<b>20-32</b>	32	24.8	20	13	50	5.3	100	19	38
<b>25-32</b>	32	24.8	25	8	50	5.3	110	23	42
<b>32-32</b>	32	24.8	32	5	54	5.3	110	29	48
<b>25-45</b>	45	38.1	25	27	70	5.3	110	23	42
<b>32-45</b>	45	38.1	32	20	70	5.3	110	29	48

## Spare parts

Designation	Screw	Clamp	Wrench	
<b>TTBU 20-26</b>	SR-M6x30	BKU- 86	L-W5	
<b>TTBU 25-26</b>	SR-M6x30	BKU-105	L-W5	
<b>TTBU 20-32</b>	SR-M6x30 DIN 912	BKU-100	L-W5	
<b>TTBU 25/32-32/45</b>	SR-M6x30	BKU-110	L-W5	

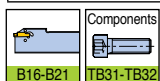



## Cartridge for external turning and grooving

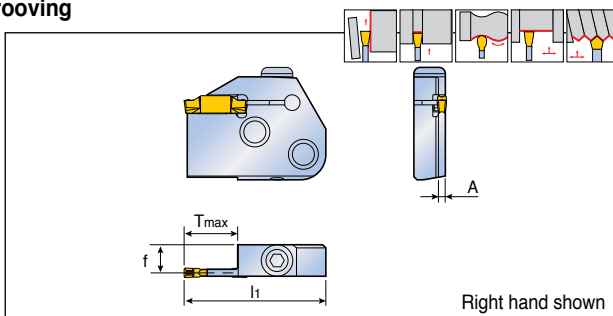

Designation	Insert seat size	Dimension (mm)				Insert	Holder
		l <sub>1</sub>	A	f	T <sub>max</sub>		
<b>TCER/L 1.4T12</b>	1	41	1.0	9.5	12	TDJ 1.4	C.-TCHN
<b>2T16</b>	2	45	1.8	9.1	16	TDC <sup>(1)</sup> / J <sup>(1)</sup> / T	C.-TCHPN
<b>2T22</b>	2	51	1.8	9.1	22	TDXU / XT	TCHR/L
<b>3T16</b>	3	45	2.4	8.8	16	TSC <sup>(1)</sup> / J <sup>(1)</sup>	TCHPR/L
<b>3T22</b>	3	51	2.4	8.8	22	B64-B73	B28-B31
<b>4T16</b>	4	45	3.0	8.5	16		
<b>4T22</b>	4	51	3.0	8.5	22		
<b>5T20</b>	5	49	4.0	8.0	20		
<b>5T25</b>	5	54	4.0	8.0	25		
<b>6T20</b>	6	49	5.0	7.5	20		
<b>6T25</b>	6	54	5.0	7.5	25		

- <sup>(1)</sup> Insert for grooving only
- Ordering example: 2 pcs. TCER 3T16

## Spare parts

Designation	Screw	Wrench		
<b>TCER/L</b>	BH M6x1x20	L-W4		

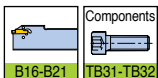

## Cartridge for external face grooving and turning

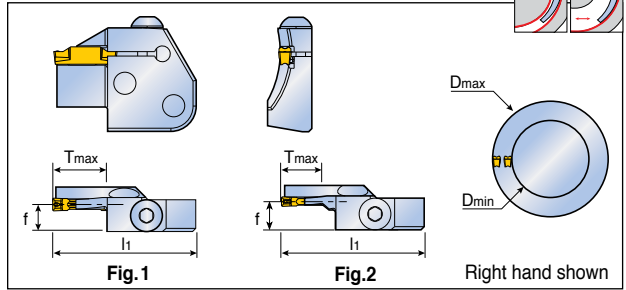

Designation	Insert seat size	Dimension (mm)					Fig.	Insert	Holder
		l <sub>1</sub>	f	T <sub>max</sub>	D <sub>min</sub>	D <sub>max</sub>			
<b>TCFR/L 3T12-40-55 RN</b>	3	45	8.9	12	40	55	2	TDC <sup>(1)</sup> / J <sup>(1)</sup> / T	C.-TCHN
<b>3T12-55-75 RN</b>	3	45	8.9	12	55	75	2	TDXU / XT	C.-TCHPN
<b>3T12-75-100 RN</b>	3	45	8.9	12	75	100	2	TSC <sup>(1)</sup> / J <sup>(1)</sup>	TCHR/L
<b>3T12-100-140 RN</b>	3	45	8.9	12	100	140	2	B64-B73	TCHPR/L
<b>3T12-140-200 RN</b>	3	45	8.9	12	140	200	2		B28-B31
<b>4T16-50-70 RN</b>	4	45	8.5	16	50	70	1		
<b>4T16-70-100 RN</b>	4	45	8.5	16	70	100	1		
<b>4T16-100-150 RN</b>	4	45	8.5	16	100	150	1		
<b>4T16-150-250 RN</b>	4	45	8.5	16	150	250	1		
<b>4T16-250 RN</b>	4	45	8.5	16	250	∞	1		
<b>5T20-55-80 RN</b>	5	49	8.0	20	55	80	1		
<b>5T20-80-120 RN</b>	5	49	8.0	20	80	120	1		
<b>5T20-120-180 RN</b>	5	49	8.0	20	120	180	1		
<b>5T20-180-300 RN</b>	5	49	8.0	20	180	300	1		
<b>5T20-300 RN</b>	5	49	8.0	20	300	∞	1		
<b>6T25-60-90 RN</b>	6	55	7.5	25	60	90	1		
<b>6T25-90-150 RN</b>	6	55	7.5	25	90	150	1		
<b>6T25-150-250 RN</b>	6	55	7.5	25	150	250	1		
<b>6T25-250-400 RN</b>	6	55	7.5	25	250	400	1		
<b>6T25-400 RN</b>	6	55	7.5	25	400	∞	1		

- <sup>(1)</sup> Insert for grooving only
- Ordering example: 5 pcs. TCFR 3T12-40-55RN
- Please check insert min. dia for face grooving [B43](#) page

## Spare parts

Designation	Screw	Wrench		
<b>TCFR/L</b>	BH M6x1x20	L-W4		



# TQCR/L

QUAD-RUSH

Cartridge for grooving, parting and recessing

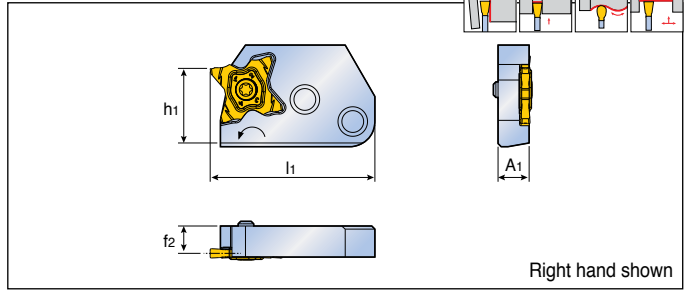

Designation	Dimension (mm)					Insert	Holder
	f <sub>2</sub> <sup>(1)</sup>	l <sub>1</sub>	W <sub>range</sub>	h <sub>1</sub>	A <sub>1</sub>		
<b>TQCR 27</b>	8.8	53	0.5 ≤ W < 5.3	24	10	TQ.. 27...	C..-TCHN
<b>TQCL 27</b>	8.8	53	0.5 ≤ W < 5.3	24	10	B96-B102	C..-TCHPN TCHR/L TCHPR/L B28-B31

• <sup>(1)</sup> "f<sub>2</sub>" value is based on TQ.. 27 standard insert

## Spare parts

Designation	Screw	Wrench		
<b>TQCR 27</b>	TS 50125IL	T 10 / 20		
<b>TQCL 27</b>	TS 50125I	T 10 / 20		



## Parallel holders

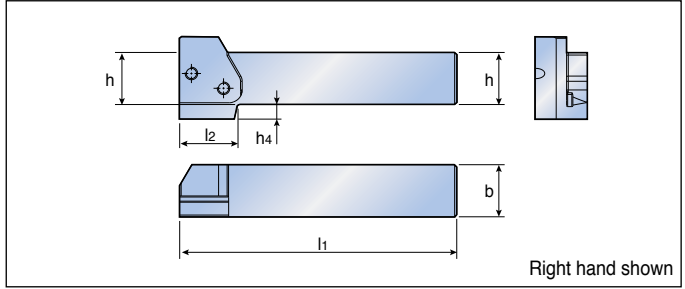
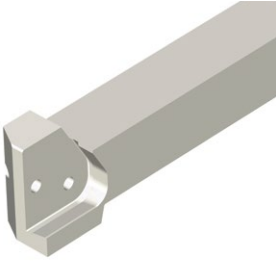

Designation	Dimension (mm)					Cartridge
	h	b	l <sub>1</sub>	l <sub>2</sub>	h <sub>4</sub>	
<b>TCHR/L 2020</b>	20	20	133	35	12	TCER/L / TCFR/L TQCR/L B25-B27
<b>2525</b>	25	25	133	28	7	
<b>3232</b>	32	32	153	28	-	

• Ordering example: 2 pcs. TCHR 2525

## Spare parts

Designation	Clamp screw	Wrench		
<b>TCHR/L</b>	 TS 601901	 L-W4		



## Perpendicular holders

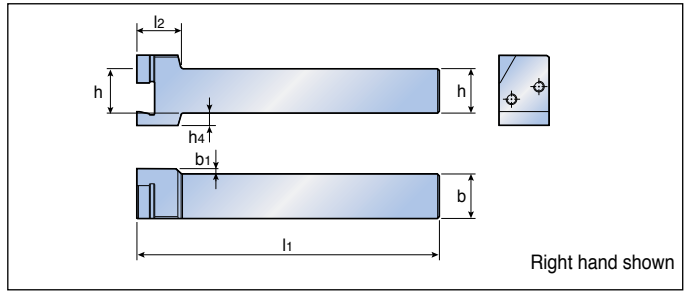
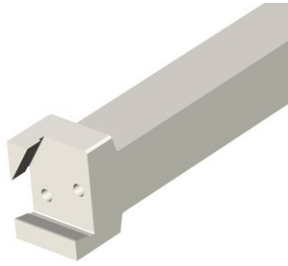

Designation	Dimension (mm)						Cartridge
	h	b	l1	l2	b1	h4	
<b>TCHPR/L 2020</b>	20	20	150	25	8	12	TCER/L / TCFR/L TQCR/L B25-B27
<b>2525</b>	25	25	150	25	3	7	
<b>3232</b>	32	32	170	25	-	-	

• Ordering example: 2 pcs. TCHPR 2525

## Spare parts

Designation	Clamp screw	Wrench		
<b>TCHPR/L</b>	TS 60190I	L-W4		



# C-ADAPTER

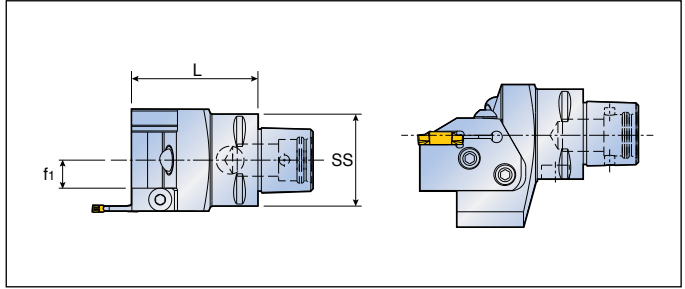

Parallel type



Designation	Dimension (mm)			Cartridge
	SS	L	f1	
<b>C4-TCHN</b>	40	55	12.2	TCER/L / TCFR/L
<b>C5-TCHN</b>	50	58	17.2	TQCR/L
<b>C6-TCHN</b>	63	60	22.2	 B25-B27

• Cartridge should be ordered separately

## Spare parts

Designation	Screw	Nozzle	Wrench	
				
<b>TCHN</b>	TS 601901	NZ-125	L-W4	



# C-ADAPTER

## Perpendicular type

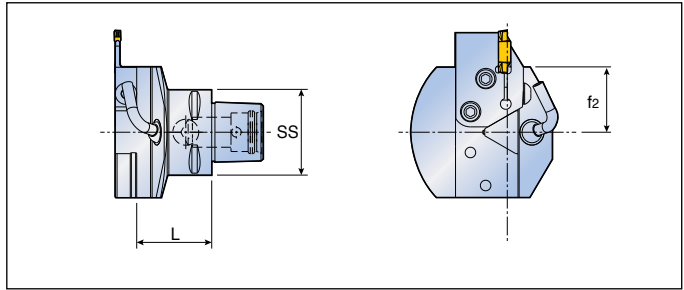
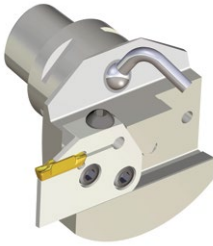

Designation	Dimension (mm)			Cartridge
	SS	L	f2	
C4-TCHPN	40	35	30.5	TCER/L / TCFR/L
C5-TCHPN	50	40	35.5	TQCR/L
C6-TCHPN	63	42	35.5	B25-B27

• Cartridge should be ordered separately

## Spare parts

Designation	Screw	Nozzle	Wrench	Pipe
TCHPN	TS 60190I	NZ-125	L-W4	NZP 5



# Cartridge and Holder Selection

## Parallel type

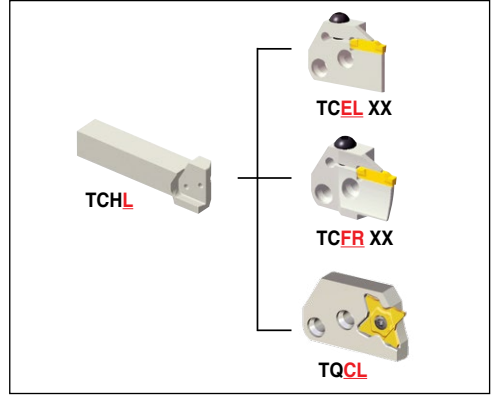
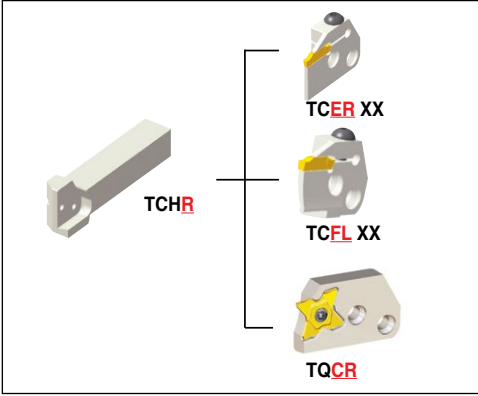

## Perpendicular type

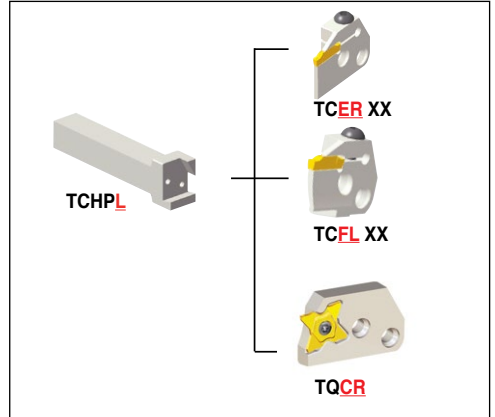
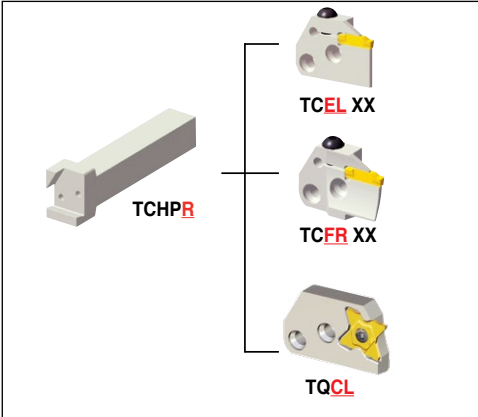

## C-ADAPTER

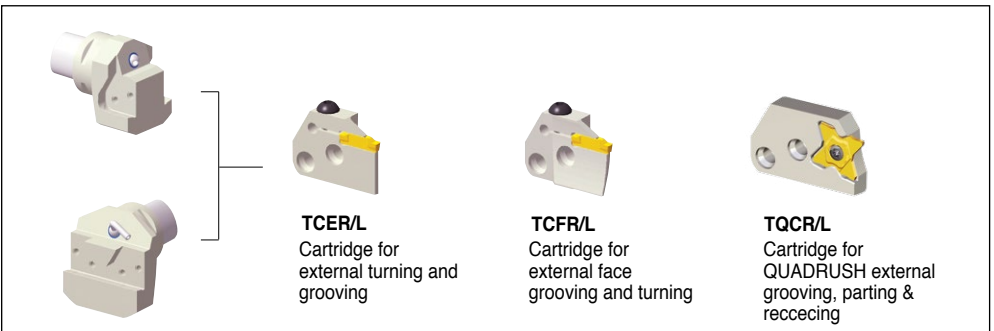



# TTER/L-SH

External turning and grooving holder for swiss automatics

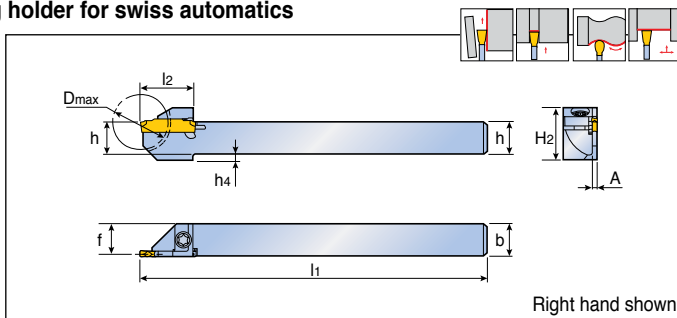

Designation	Insert seat size	Dimension (mm)									Insert
		h	b	l <sub>1</sub>	f	l <sub>2</sub>	A	h <sub>4</sub>	H <sub>2</sub>	D <sub>max</sub>	
<b>TTER/L 10-20-1.4SH</b>	1	10	10	125	9.5	18	1.0	-	13.7	20	TDC / J / T TDXU / XT TSC / J B64-B73
<b>12-24-1.4SH</b>	1	12	12	125	11.5	19.5	1.0	-	15.7	24	
<b>14-24-1.4SH</b>	1	14	14	125	13.5	19.5	1.0	-	17.7	24	
<b>16-32-1.4SH</b>	1	16	16	125	15.5	24	1.0	-	19.7	32	
<b>10-20-2SH</b>	2	10	10	125	9.1	19	1.8	2	17.5	20	
<b>12-24-2SH</b>	2	12	12	125	11.1	19	1.8	2	19.0	24	
<b>14-24-2SH</b>	2	14	14	125	13.1	19	1.8	-	19.0	24	
<b>16-32-2SH</b>	2	16	16	125	15.1	24	1.8	-	21.0	32	
<b>12-24-3SH</b>	3	12	12	125	10.8	19	2.4	2	19.0	24	
<b>16-32-3SH</b>	3	16	16	125	14.8	24	2.4	-	21.0	32	

## Spare parts

Designation	Screw	Wrench		
<b>TTER/L- SH</b>	TS 40A115I	T15		



## Reinforced external turning and grooving

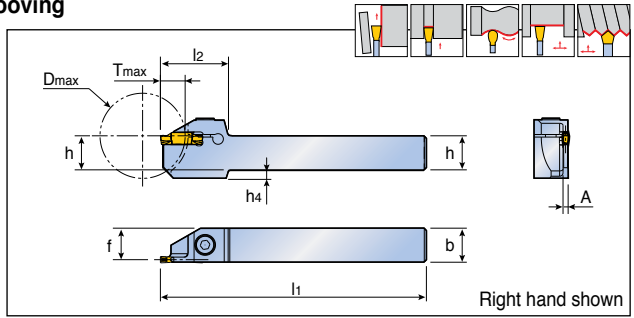
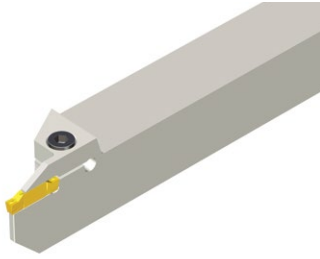

Designation	Insert seat size	Dimension (mm)									Insert
		h	b	l <sub>1</sub>	f	l <sub>2</sub>	h <sub>4</sub>	A	T <sub>max</sub>	D <sub>max</sub>	
<b>TTER/L 1010-1.4T15-D40</b>	1	10	10	125	9.5	32	6	1.0	15	40	TDC / J / T TDXU / XT TSC / J B64-B73
<b>1212-1.4T15-D40</b>	1	12	12	125	11.5	32	4	1.0	15	40	
<b>1616-1.4T20-D45</b>	1	16	16	125	15.5	38	4	1.0	20	45	
<b>2020-1.4T20-D45</b>	1	20	20	125	19.5	38	-	1.0	20	45	
<b>1010-2T15-D40</b>	2	10	10	125	9.1	32	6	1.8	15	40	
<b>1212-2T15-D40</b>	2	12	12	125	11.1	32	4	1.8	15	40	
<b>1616-2T20-D45</b>	2	16	16	125	15.1	38	4	1.8	20	45	
<b>2020-2T20-D45</b>	2	20	20	125	19.1	38	-	1.8	20	45	
<b>2525-2T20-D45</b>	2	25	25	150	24.1	38	-	1.8	20	45	
<b>1212-3T15-D40</b>	3	12	12	125	10.8	32	4	2.4	15	40	
<b>1616-3T20-D45</b>	3	16	16	125	14.8	38	4	2.4	20	45	
<b>2020-3T20-D45</b>	3	20	20	125	18.8	38	-	2.4	20	45	
<b>2525-3T20-D45</b>	3	25	25	150	23.8	38	-	2.4	20	45	
<b>2525-3T25-D60</b>	3	25	25	150	23.8	43	-	2.4	25	60	

## Spare parts

Designation	Screw	Wrench		
<b>TTER/L-D</b>	SH M5x0.8x16	L-W 4		

Components



## Machining depth for diameter of workpiece

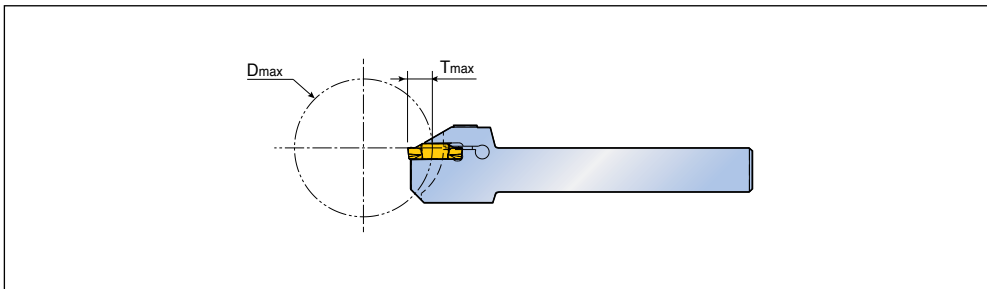

Designation	Dmax	Tmax														
		1	2	3	4	5	6	7	8	9	10	11	12	13		
TTER/L 1010-1.4T15-D40						∞							269	120	79	
1212-1.4T15-D40						∞							269	120	79	
1616-1.4T20-D45						∞										432
2020-1.4T20-D45						∞										432
1010-2T15-D40						∞							269	120	79	
1212-2T15-D40						∞							269	120	79	
1616-2T20-D45						∞										432
2020-2T20-D45						∞										432
2525-2T20-D45						∞					1468	339	193	136	106	
1212-3T15-D40						∞							269	120	79	
1616-3T20-D45						∞										432
2020-3T20-D45						∞										432
2525-3T20-D45						∞					1468	339	193	136	106	
2525-3T25-D60						∞										

Designation	Dmax	Tmax													
		14	15	16	17	18	19	20	21	22	23	24	25		
TTER/L 1010-1.4T15-D40		59	40												
1212-1.4T15-D40		59	40												
1616-1.4T20-D45		193	125	94	76	64	57	45							
2020-1.4T20-D45		193	125	94	76	64	57	45							
1010-2T15-D40		59	40												
1212-2T15-D40		59	40												
1616-2T20-D45		193	125	94	76	64	57	45							
2020-2T20-D45		193	125	94	76	64	57	45							
2525-2T20-D45		87	75	67	60	56	52	45							
1212-3T15-D40		59	40												
1616-3T20-D45		193	125	94	76	64	57	45							
2020-3T20-D45		193	125	94	76	64	57	45							
2525-3T20-D45		87	75	67	60	56	52	45							
2525-3T25-D60					1810	418	237	167	130	107	91	81	73	60	

## External turning and grooving

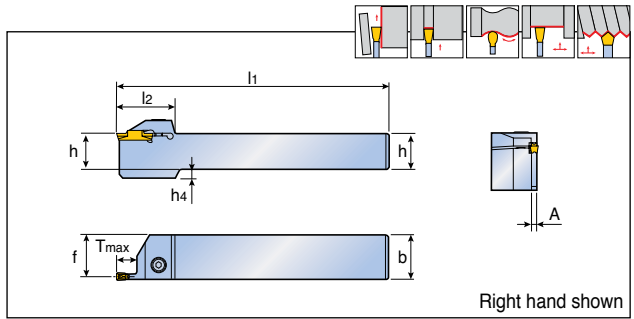
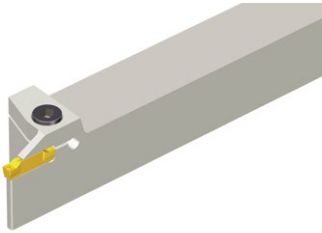

Designation	Insert seat size	Dimension (mm)								Insert
		h	b	l <sub>1</sub>	f	l <sub>2</sub>	A	h <sub>4</sub>	T <sub>max</sub>	
<b>TTER/L 1616-2T08</b>	2	16	16	110	15.1	33	1.8	4	8.0	TDC / J / T / A TDXU / XT TSC / J / A B64-B77
<b>2020-2T08</b>	2	20	20	125	19.1	33	1.8	-	8.0	
<b>2525-2T08</b>	2	25	25	150	24.1	33	1.8	-	8.0	
<b>1616-2</b>	2	16	16	110	15.1	32	1.8	4	12.0	
<b>2020-2</b>	2	20	20	125	19.1	32	1.8	-	12.0	
<b>2525-2</b>	2	25	25	150	24.1	32	1.8	-	12.0	
<b>1616-2T17</b>	2	16	16	110	15.1	37	1.8	4	17.0	
<b>2020-2T17</b>	2	20	20	125	19.1	37	1.8	-	17.0	
<b>2525-2T17</b>	2	25	25	150	24.1	37	1.8	-	17.0	
<b>TTER/L 1616-3T09</b>	3	16	16	110	14.8	32	2.4	4	9.0	
<b>2020-3T09</b>	3	20	20	125	18.8	32	2.4	-	9.0	
<b>2525-3T09</b>	3	25	25	150	23.8	32	2.4	-	9.0	
<b>1616-3</b>	3	16	16	110	14.8	32	2.4	4	12.0	
<b>2020-3</b>	3	20	20	125	18.8	32	2.4	-	12.0	
<b>2525-3</b>	3	25	25	150	23.8	32	2.4	-	12.0	
<b>1616-3T20</b>	3	16	16	110	14.8	38.5	2.4	-	20.0	
<b>2020-3T20</b>	3	20	20	125	18.8	38.5	2.4	-	20.0	
<b>2525-3T20</b>	3	25	25	150	23.8	38.5	2.4	-	20.0	
<b>2525-3T25</b>	3	25	25	150	23.8	44.5	2.4	-	25.0	
<b>TTER/L 1616-4T10</b>	4	16	16	110	14.5	32	3.0	4	10.0	
<b>2020-4T10</b>	4	20	20	125	18.5	32	3.0	-	10.0	
<b>2525-4T10</b>	4	25	25	150	23.5	32	3.0	-	10.0	
<b>1616-4</b>	4	16	16	110	14.5	33	3.0	4	15.0	
<b>2020-4</b>	4	20	20	125	18.5	33	3.0	-	15.0	
<b>2525-4</b>	4	25	25	150	23.5	33	3.0	-	15.0	
<b>1616-4T25</b>	4	16	16	110	14.5	45	3.0	-	25.0	
<b>2020-4T25</b>	4	20	20	125	18.5	45	3.0	-	25.0	
<b>2525-4T25</b>	4	25	25	150	23.5	45	3.0	-	25.0	
<b>TTER/L 2020-5T12</b>	5	20	20	125	18.1	37	4.0	-	12.0	
<b>2525-5T12</b>	5	25	25	150	23.1	37	4.0	-	12.0	
<b>2020-5</b>	5	20	20	125	18.1	37	4.0	-	20.0	
<b>2525-5</b>	5	25	25	150	23.1	37	4.0	-	20.0	
<b>2525-5T32</b>	5	25	25	150	23.0	56	4.0	-	32.0	



## External turning and grooving

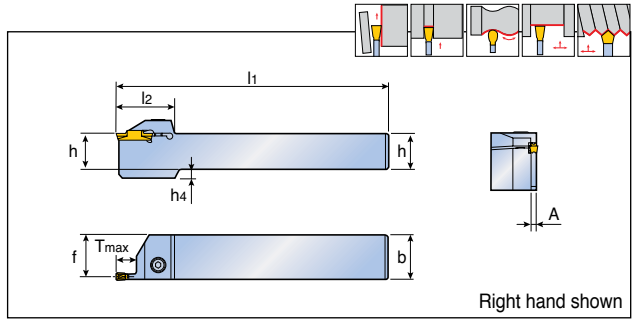
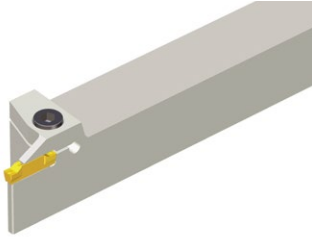

Designation	Insert seat size	Dimension (mm)								Insert
		h	b	l <sub>1</sub>	f	l <sub>2</sub>	A	h <sub>4</sub>	T <sub>max</sub>	
<b>TTER/L 2020-6T12</b>	6	20	20	125	17.6	37	5.0	-	12.0	TDC / J / T / A
<b>2525-6T12</b>	6	25	25	150	22.6	37	5.0	7	12.0	TDXU / XT
<b>2020-6</b>	6	20	20	125	17.6	41	5.0	-	20.0	TSC / J / A
<b>2525-6</b>	6	25	25	150	22.6	41	5.0	7	20.0	B64-B77
<b>2525-6T32</b>	6	25	25	150	22.5	56	5.0	7	32.0	
<b>TTER/L 2525-8T16</b>	8	25	25	150	22.1	47	6.0	7	16.0	
<b>2525-8</b>	8	25	25	150	22.1	47	6.0	7	25.0	
<b>3232-8</b>	8	32	32	170	29.1	47	6.0	-	25.0	
<b>2525-8T36</b>	8	25	25	150	22.1	60	6.0	7	36.0	
<b>3232-8T36</b>	8	32	32	170	29.1	60	6.0	-	36.0	
<b>TTER/L 2525-10T25</b>	10	25	25	150	21.1	50	7.85	7	25.0	
<b>3232-10T25</b>	10	32	32	170	28.1	50	7.85	-	25.0	
<b>4040-10T25</b>	10	40	40	200	36.1	50	7.85	-	25.0	

## Spare parts

Designation	Screw	Wrench		
<b>TTER/L 1616-2/3</b>	SH M5x0.8x16	L-W 4		
<b>TTER/L 2020-2/3</b>	SH M5x0.8x20	L-W 4		
<b>TTER/L 2525-2/3</b>	SH M5x0.8x25	L-W 4		
<b>TTER/L 1616-4/5</b>	SH M6x1x16	L-W 5		
<b>TTER/L 2020-4/5</b>	SH M6x1x20	L-W 5		
<b>TTER/L 2525-4/5</b>	SH M6x1x25	L-W 5		
<b>TTER/L 2020-6</b>	SH M8x1.25x20	L-W 6		
<b>TTER/L 2525-6/8</b>	SH M8x1.25x25	L-W 6		
<b>TTER/L 3232-8/10</b>	SH M8x1.25x25	L-W 6		
<b>TTER/L 4040-10</b>	SH M8x1.25x25	L-W 6		

Components



TB31-TB32

## External turning and grooving

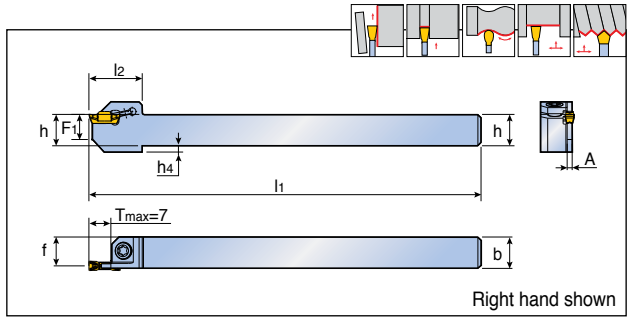
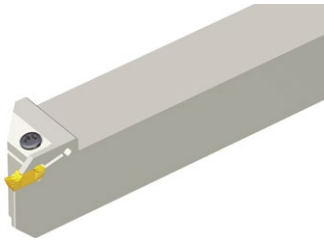

Designation	Insert seat size	Dimension (mm)								Insert
		h	b	l <sub>1</sub>	f	F <sub>1</sub>	l <sub>2</sub>	A	h <sub>4</sub>	
<b>TTSER/L 1010-2T7</b>	2	10	10	125	9.2	8	17	1.6	2	TDIM / IP B75, B76
<b>1212-2T7</b>	2	12	12	125	11.2	8	17	1.6	-	
<b>1616-2T7</b>	2	16	16	125	15.2	11	20	1.6	-	
<b>2020-2T7</b>	2	20	20	125	19.2	14	20	1.6	-	
<b>2525-2T7</b>	2	25	25	125	24.2	18	20	1.6	-	
<b>1010-3T7</b>	3	10	10	125	8.8	8	17	2.4	2	
<b>1212-3T7</b>	3	12	12	125	10.8	8	17	2.4	-	
<b>1616-3T7</b>	3	16	16	125	14.8	11	20	2.4	-	
<b>2020-3T7</b>	3	20	20	125	18.8	14	20	2.4	-	
<b>2525-3T7</b>	3	25	25	125	23.8	18	20	2.4	-	

## Spare parts

Designation	Screw	Wrench		
<b>TTSER/L</b>	TS 400971	T 15		



## Shallow turning and grooving

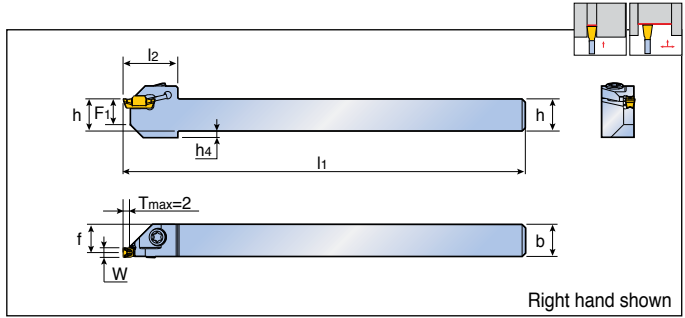
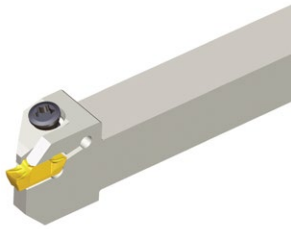

Designation	Insert seat size	Dimension (mm)								Insert
		h	b	l <sub>1</sub>	f	F <sub>1</sub>	l <sub>2</sub>	h <sub>4</sub>	W	
<b>TGSFR/L 1010-3T2</b>	2, 3	10	10	125	8.8	8	17	2	≤ 3	TDIM / IP B75, B76
<b>1212-3T2</b>	2, 3	12	12	125	10.8	8	17	-	≤ 3	
<b>1616-3T2</b>	2, 3	16	16	125	14.8	11	20	-	≤ 3	

## Spare parts

Designation	Screw	Wrench		
	<b>TGSFR/L</b>	 TS 400971	 T 15	



## External face grooving and turning

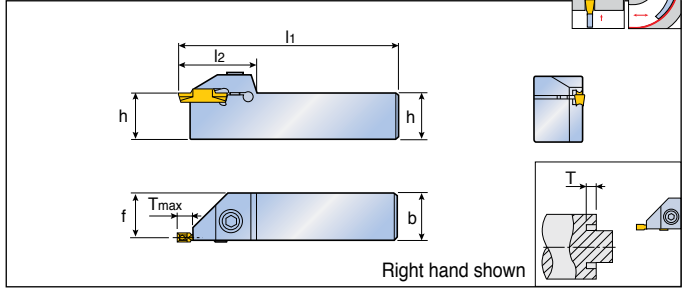
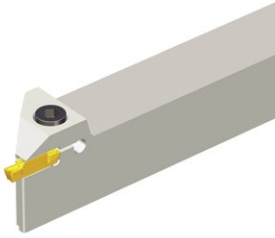

Designation	Insert seat size	Dimension (mm)						Insert
		h	b	l <sub>1</sub>	f	l <sub>2</sub>	T <sub>max</sub>	
<b>TGFR/L 1616-4</b>	2, 3, 4	16	16	110	14.6	33	4.8	TDC <sup>(1)</sup> / J <sup>(1)</sup> / T TDXU / XT / FT TSC <sup>(1)</sup> / J <sup>(1)</sup> B64-B73
<b>2020-4</b>	2, 3, 4	20	20	125	18.6	33	4.8	
<b>2525-4</b>	2, 3, 4	25	25	150	23.6	33	4.8	
<b>2020-6</b>	5, 6	20	20	125	17.6	37	4.8	
<b>2525-6</b>	5, 6	25	25	150	22.6	37	4.8	

- <sup>(1)</sup> Insert for grooving only
- External turning & grooving is available depending on the insert type
- Please check insert min. dia for face grooving B43 page

## Spare parts

Designation	Screw	Wrench		
<b>TGFR/L 1616</b>	SH M6x1x16	L-W5		
<b>TGFR/L 2020</b>	SH M6x1x20	L-W5		
<b>TGFR/L 2525</b>	SH M6x1x25	L-W5		





## Deep face grooving and turning

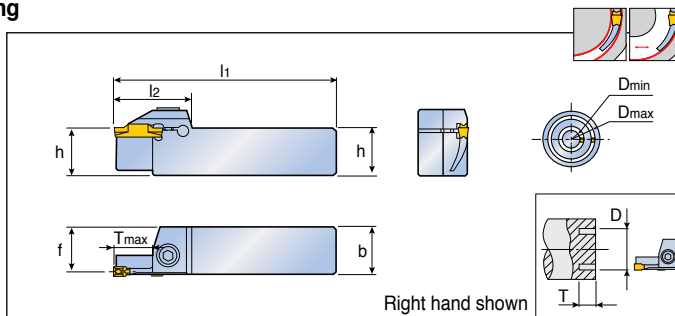
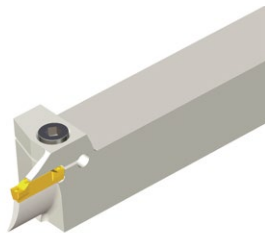

Designation	Insert seat size	Dimension (mm)									Insert
		h	b	l <sub>1</sub>	f	l <sub>2</sub>	T <sub>max</sub>	D <sub>min</sub>	D <sub>max</sub>		
<b>TTFR/L 25-30-3</b>	3	25	25	150	24.0	32	10	24	35	TDC <sup>(1)</sup> / J <sup>(1)</sup> / T TDXU / XT / FT TSC <sup>(1)</sup> / J <sup>(1)</sup> B64-B73	
<b>25-35-3</b>	3	25	25	150	24.0	32	10	29	40		
<b>25-40-3</b>	3	25	25	150	24.0	32	10	34	50		
<b>25-50-3</b>	3	25	25	150	24.0	32	15	44	60		
<b>25-60-3</b>	3	25	25	150	24.0	32	15	54	85		
<b>25-30-4</b>	4	25	25	150	23.6	33	12	22	40		
<b>25-40-4</b>	4	25	25	150	23.6	33	15	32	50		
<b>25-50-4</b>	4	25	25	150	23.6	33	15	42	60		
<b>25-60-4</b>	4	25	25	150	23.6	33	15	52	85		
<b>25-60-5</b>	5	25	25	150	23.5	41	20	50	80		
<b>25-80-5</b>	5	25	25	150	23.5	41	20	70	110		
<b>25-110-5</b>	5	25	25	150	23.5	41	20	110	150		
<b>25-150-5</b>	5	25	25	150	23.5	41	20	140	200		
<b>25-60-6</b>	6	25	25	150	22.6	41	20	48	85		
<b>25-85-6</b>	6	25	25	150	22.6	41	20	73	150		
<b>25-150-6</b>	6	25	25	150	22.6	41	20	140	200		
<b>25-250-6</b>	6	25	25	150	22.6	41	20	250	∞		

- <sup>(1)</sup> Insert for grooving only
- Please check insert min. dia for face grooving B43 page

## Spare parts

Designation	Screw	Wrench		
<b>TTFR/L...-3</b>	SH M5x0.8x25	L-W 4		
<b>TTFR/L...-4</b>	SH M6x1x25	L-W 5		
<b>TTFR/L...-5</b>	SH M6x1x25	L-W 5		
<b>TTFR/L...-6</b>	SH M6x1x25	L-W 5		



# TTFR/L-RN (Renewed Type)

Deep face grooving and turning

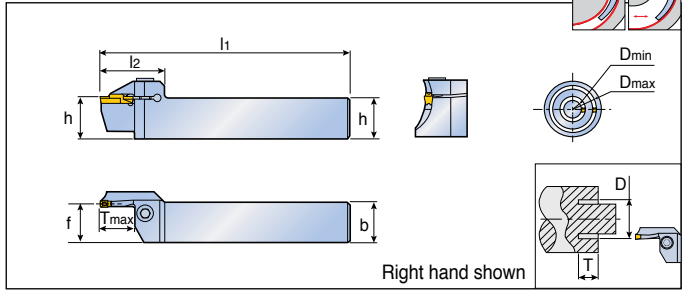
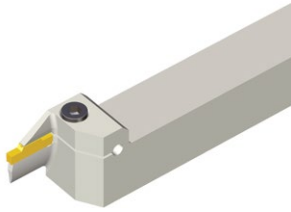

Designation	Insert seat size	Dimension (mm)								Insert
		h	b	l <sub>1</sub>	f	l <sub>2</sub>	T <sub>max</sub>	D <sub>min</sub>	D <sub>max</sub>	
<b>TTFR/L 20-21-30-3T10 RN</b>	3	20	20	140	19	31	10	21	30	TDC <sup>(1)</sup> / J <sup>(1)</sup> / T TDXU / XT / FT TSC <sup>(1)</sup> / J <sup>(1)</sup> B64-B73
<b>20-24-35-3T10 RN</b>	3	20	20	140	19	31	10	24	35	
<b>20-29-40-3T10 RN</b>	3	20	20	140	19	31	10	29	40	
<b>20-34-50-3T10 RN</b>	3	20	20	140	19	31	10	34	50	
<b>20-44-70-3T15 RN</b>	3	20	20	140	19	35	15	44	70	
<b>20-64-100-3T15 RN</b>	3	20	20	140	19	35	15	64	100	
<b>20-19-30-4T10 RN</b>	4	20	20	140	18.6	31	10	19	30	
<b>20-22-36-4T10 RN</b>	4	20	20	140	18.6	31	10	22	36	
<b>20-28-42-4T16 RN</b>	4	20	20	140	18.6	36	16	28	42	
<b>20-34-50-4T16 RN</b>	4	20	20	140	18.6	36	16	34	50	
<b>20-42-70-4T16 RN</b>	4	20	20	140	18.6	36	16	42	70	
<b>20-62-120-4T16 RN</b>	4	20	20	140	18.6	36	16	62	120	
<b>20-112-200-4T16 RN</b>	4	20	20	140	18.6	36	16	112	200	
<b>25-30-3 RN</b>	3	25	25	150	24.0	38	10.0	24	35	
<b>25-35-3 RN</b>	3	25	25	150	24.0	38	10.0	29	40	
<b>25-40-3 RN</b>	3	25	25	150	24.0	38	10.0	34	50	
<b>25-50-3 RN</b>	3	25	25	150	24.0	38	15.0	44	70	
<b>25-70-3 RN</b>	3	25	25	150	24.0	38	15.0	64	100	
<b>25-30-4 RN</b>	4	25	25	150	23.6	39	10.0	22	36	
<b>25-36-4 RN</b>	4	25	25	150	23.6	39	20.0	28	42	
<b>25-42-4 RN</b>	4	25	25	150	23.6	39	20.0	34	50	
<b>25-50-4 RN</b>	4	25	25	150	23.6	39	20.0	42	70	
<b>25-70-4 RN</b>	4	25	25	150	23.6	39	20.0	62	120	
<b>25-120-4 RN</b>	4	25	25	150	23.6	39	20.0	112	200	
<b>25-200-4 RN</b>	4	25	25	150	23.6	39	20.0	200	∞	
<b>25-60-5 RN</b>	5	25	25	150	23.1	49	25.0	50	80	
<b>25-60-5T15 RN</b>	5	25	25	150	23.1	41	15.0	50	80	
<b>25-80-5 RN</b>	5	25	25	150	23.1	49	25.0	70	110	
<b>25-80-5T15 RN</b>	5	25	25	150	23.1	41	15.0	70	110	
<b>25-110-5 RN</b>	5	25	25	150	23.1	49	25.0	100	150	
<b>25-150-5 RN</b>	5	25	25	150	23.1	49	25.0	140	200	
<b>25-200-5 RN</b>	5	25	25	150	23.1	49	25.0	200	∞	



- <sup>(1)</sup> Insert for grooving only
- Please check insert min. dia for face grooving B43 page

TB31-TB32

# TTFR/L-RN (Renewed Type)

## Deep face grooving and turning

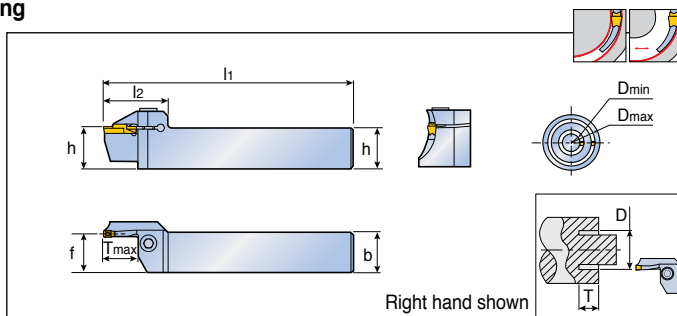
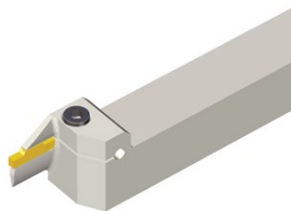

Designation	Insert seat size	Dimension (mm)								Insert
		h	b	l <sub>1</sub>	f	l <sub>2</sub>	T <sub>max</sub>	D <sub>min</sub>	D <sub>max</sub>	
<b>TTFR/L 25-60-6 RN</b>	6	25	25	150	22.6	49	25.0	48	70	TDC <sup>(1)</sup> / J <sup>(1)</sup> / T TDXU / XT / FT TSC <sup>(1)</sup> / J <sup>(1)</sup> B64-B73
<b>25-70-6 RN</b>	6	25	25	150	22.6	49	25.0	58	100	
<b>25-100-6 RN</b>	6	25	25	150	22.6	49	25.0	88	180	
<b>25-180-6 RN</b>	6	25	25	150	22.6	49	25.0	168	400	
<b>25-400-6 RN</b>	6	25	25	150	22.6	49	25.0	400	∞	

- <sup>(1)</sup> Insert for grooving only
- Please check insert min. dia for face grooving B43 page

### Insert initial min.Dia (Dmin) for face grooving

Machining	Insert	Size (mm)	Min. dia. (mm)	Insert	Size (mm)	Min. dia. (mm)
Facing Min. dia. of face machining 	TDJ/C	3	54	TDT RU	3	41
		4	34		4	36
		5	49		5	54
		6	46		6	54
	TDT	3	44	TDXU	3	18
		4	42		4	18
		5	50		5	20
		6	48		6	18

### Spare parts

Designation	Screw	Wrench		
<b>TTFR/L 20...RN</b>	SH M6x1x20	L-W 5		
<b>TTFR/L 25...3/4 RN</b>	SH M6x1x25	L-W 5		
<b>TTFR/L 25...5/6 RN</b>	SH M8x1.25x25	L-W 6		

Components



TB31-TB32

## Shallow face perpendicular grooving and face turning

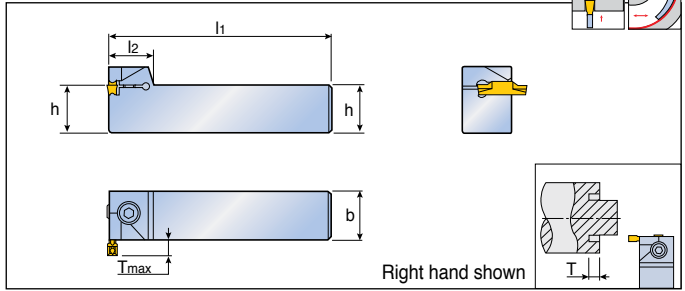
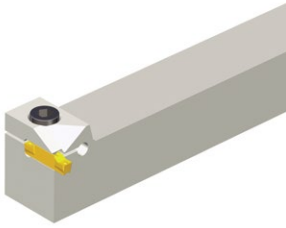

Designation	Insert seat size	Dimension (mm)					Insert
		h	b	l1	l2	Tmax	
<b>TGFPR/L 2020-4</b>	2, 3, 4	20	20	125	18	4.8	TDC <sup>(1)</sup> / J <sup>(1)</sup> / T
<b>2525-4</b>	2, 3, 4	25	25	150	18	4.8	TDXU / XT / FT
<b>2525-6</b>	5, 6	25	25	150	22	4.8	TSC <sup>(1)</sup> / J <sup>(1)</sup>
							B64-B73

- <sup>(1)</sup> Insert for grooving only
- External Turning & Grooving is available depending on the insert
- Please check insert min. dia for face grooving [B43](#) page

## Spare parts

Designation	Screw	Wrench		
<b>TGFPR/L 2020</b>	SH M6x1x20	L-W5		
<b>TGFPR/L 2525</b>	SH M6x1x25	L-W5		
<b>TGFPR/L 2525</b>	SH M6x1x25	L-W5		

Components  
  
**TB31-TB32**

## Deep face grooving and turning

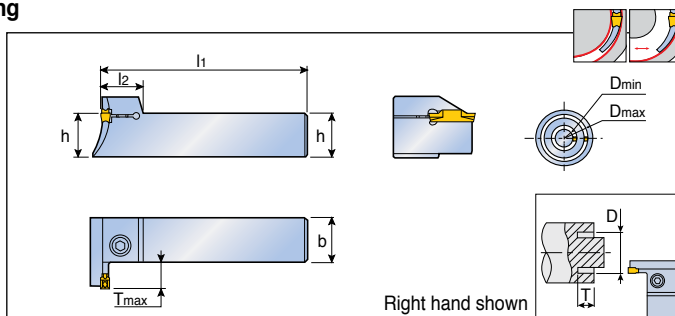

Designation	Insert seat size	Dimension (mm)							Insert
		h	b	l <sub>1</sub>	l <sub>2</sub>	T <sub>max</sub>	D <sub>min</sub>	D <sub>max</sub>	
<b>TTFPR/L 25-30-3</b>	3	25	25	150	18	10	24	35	TDC <sup>(1)</sup> / J <sup>(1)</sup> / T
<b>25-35-3</b>	3	25	25	150	18	10	29	40	TDXU / XT / FT
<b>25-40-3</b>	3	25	25	150	18	10	34	50	TSC <sup>(1)</sup> / J <sup>(1)</sup>
<b>25-50-3</b>	3	25	25	150	18	15	44	60	B64-B73
<b>25-60-3</b>	3	25	25	150	18	15	54	85	
<b>25-30-4</b>	4	25	25	150	18.5	12	22	40	
<b>25-40-4</b>	4	25	25	150	18.5	15	32	50	
<b>25-50-4</b>	4	25	25	150	18.5	15	42	60	
<b>25-60-4</b>	4	25	25	150	18.5	15	52	85	
<b>25-60-5</b>	5	25	25	150	22	20	50	80	
<b>25-80-5</b>	5	25	25	150	22	20	70	110	
<b>25-110-5</b>	5	25	25	150	22	20	100	150	
<b>25-150-5</b>	5	25	25	150	22	20	140	200	
<b>25-200-5</b>	5	25	25	150	22	20	200	∞	
<b>25-60-6</b>	6	25	25	150	22	20	48	85	
<b>25-85-6</b>	6	25	25	150	22	20	73	150	
<b>25-150-6</b>	6	25	25	150	22	20	138	250	
<b>25-250-6</b>	6	25	25	150	22	20	250	∞	

- <sup>(1)</sup> Insert for grooving only
- Please check insert min. dia for face grooving B43 page

## Spare parts

Designation	Screw	Wrench		
<b>TTFPR/L...-3</b>	SH M5x0.8x25	L-W 4		
<b>TTFPR/L...-4</b>	SH M6x1x25	L-W 5		
<b>TTFPR/L...-5</b>	SH M8x1.25x25	L-W 6		
<b>TTFPR/L...-6</b>	SH M8x1.25x25	L-W 6		

Components



TB31-TB32

## Shallow internal face grooving and face turning

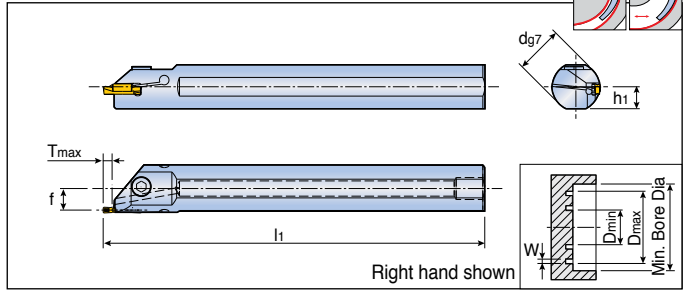

Designation	Insert seat size	Dimension (mm)					Insert
		d	l <sub>1</sub>	f	h <sub>1</sub>	T <sub>max</sub>	
<b>TGIFR/L 25-4C-T5.5</b>	3, 4	25	200	11.3	11.5	5.5	TDC <sup>(1)</sup> / J <sup>(1)</sup> / T
<b>32-4C-T5.5</b>	3, 4	32	250	14.8	15	5.5	TDXU / XT / FT
<b>25-6C-T5.5</b>	5, 6	25	200	10.3	11.5	5.5	TSC <sup>(1)</sup> / J <sup>(1)</sup>
<b>32-6C-T5.5</b>	5, 6	32	250	13.8	15	5.5	B64-B73

- <sup>(1)</sup> Insert for grooving only
- Please check insert min. dia for face grooving [B43](#) page

W	Min. bore dia		D <sub>min</sub>		D <sub>max</sub>
	d=25	d=32	TDFT / TDXU	TDT / TDC / TDJ	
<b>3</b>	26.3	33.3	20	44	∞
<b>4</b>	26.8	33.8	18	42	
<b>5</b>	26.3	33.3	20	50	
<b>6</b>	26.8	33.8	18	48	

## TGIFR/L Application

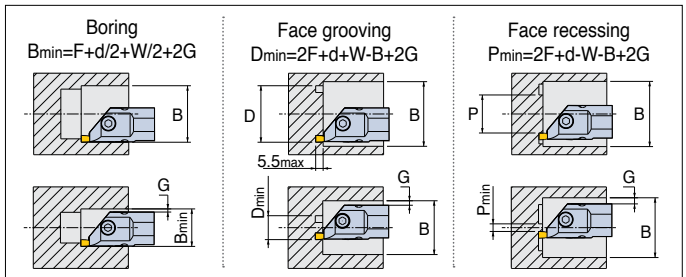

## Spare parts

Designation	Screw	Wrench	Seal	
<b>TGIFR/L 25</b>	SH M6x1x16	L-W5	PL 25 (R1/8")	
<b>TGIFR/L 32</b>	SH M6x1x16	L-W5	PL 32 (R1/8")	



## Internal face grooving and face turning

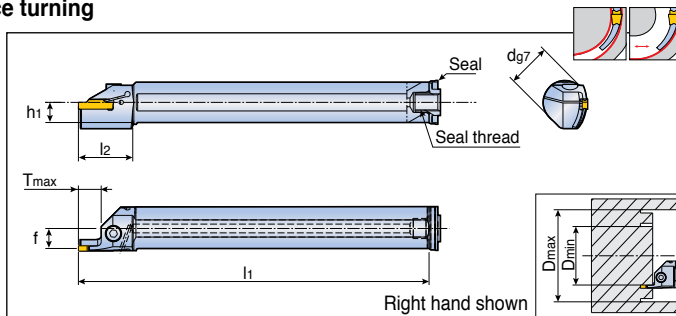

Designation	Insert seat size	Dimension (mm)								Insert
		d	l <sub>1</sub>	l <sub>2</sub>	f	h <sub>1</sub>	T <sub>max</sub>	D <sub>min</sub>	D <sub>max</sub>	
<b>TTFIR/L 25-3T12 20-33</b>	3	25	200	31	11.5	11.5	12	20	33	TDC <sup>(1)</sup> / J <sup>(1)</sup> / T TDXU / XT / FT TSC <sup>(1)</sup> / J <sup>(1)</sup> B64-B73
<b>25-3T12 26-39</b>	3	25	200	31	11.5	11.5	12	26	39	
<b>25-3T12 33-48</b>	3	25	200	31	11.5	11.5	12	33	48	
<b>25-3T12 42-60</b>	3	25	200	31	11.5	11.5	12	42	60	
<b>25-3T12 54-85</b>	3	25	200	31	11.5	11.5	12	54	85	
<b>25-3T12 79-150</b>	3	25	200	31	11.5	11.5	12	79	150	
<b>25-4T12 18-34</b>	4	25	200	31	11	11.5	12	18	34	
<b>25-4T12 26-42</b>	4	25	200	31	11	11.5	12	26	42	
<b>25-4T12 34-55</b>	4	25	200	31	11	11.5	12	34	55	
<b>32-4T12 47-70</b>	4	32	250	31	14.5	15.0	12	47	70	
<b>32-4T12 62-100</b>	4	32	250	31	14.5	15.0	12	62	100	
<b>32-4T12 92-180</b>	4	32	250	31	14.5	15.0	12	92	180	

- <sup>(1)</sup> Insert for grooving only
- Please check insert min. dia for face grooving B43 page

## Spare parts

Designation	Screw	Wrench	Seal	
<b>TTFIR/L 25</b>	SH M5x0.8x16	L-W 4	PL 25 (R1/8")	
<b>TTFIR/L 32</b>	SH M5x0.8x16	L-W 4	PL 32 (R1/8")	



## Internal turning, grooving and profiling

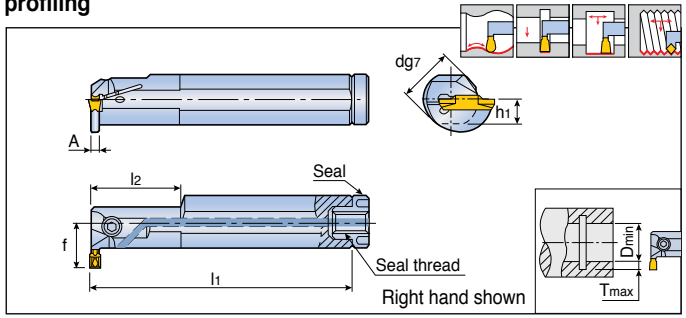

Designation	Insert seat size	Dimension (mm)								Insert
		d	l <sub>1</sub>	l <sub>2</sub>	f	h <sub>1</sub>	A	T <sub>max</sub>	D <sub>min</sub>	
<b>TTIR/L 16-2C</b>	2	16	125	-	16.5	7.5	1.8	8.5	25	TDC <sup>(1)</sup> / J <sup>(1)</sup> / T
<b>20-2C</b>	2	20	160	40	15.8	9.0	1.6	6.0	25	TDXU / XT / FT / IT
<b>25-2C</b>	2	25	200	40	17.5	11.5	1.6	5.0	25	TSC <sup>(1)</sup> / J <sup>(1)</sup>
<b>20-3C</b>	3	20	160	40	15.8	9.0	2.1	6.0	25	B64-B74
<b>25-3C</b>	3	25	200	40	17.5	11.5	2.1	5.1	25	
<b>25-3C-T8</b>	3	25	200	40	21.5	11.5	2.4	8	32	
<b>32-3C</b>	3	32	250	60	19.8	14.0	2.1	4.7	31	
<b>32-3C-T10</b>	3	32	250	60	27	15	2.4	10	40	
<b>40-3C-T12</b>	3	40	300	65	33	19	2.4	12	50	
<b>20-4C</b>	4	20	160	40	15.8	9.0	2.9	6.0	25	
<b>25-4C</b>	4	25	200	40	17.5	11.5	2.9	5.2	25	
<b>25-4C-T8</b>	4	25	200	40	21.5	11.5	3.0	8	32	
<b>32-4C</b>	4	32	250	60	20.8	14.0	2.9	4.7	31	
<b>32-4C-T10</b>	4	32	250	60	27	15	3.0	10	40	
<b>40-4C-T12</b>	4	40	300	65	33	19	3.0	12	50	
<b>50-4C-T14</b>	4	50	350	70	40	23.5	3.0	14	60	
<b>25-5C</b>	5	25	200	40	17.3	11.5	3.9	5.2	31	
<b>32-5C</b>	5	32	250	60	20.8	14.0	3.9	4.7	31	
<b>32-5C-T10</b>	5	32	250	60	27	15	3.85	10	40	
<b>40-5C-T12</b>	5	40	300	65	33	19	3.85	12	50	
<b>50-5C-T14</b>	5	50	350	70	40	23.5	3.85	14	60	
<b>32-6C</b>	6	32	250	60	20.8	14.0	4.9	4.7	31	
<b>32-6C-T10</b>	6	32	250	60	27	15	4.85	10	40	
<b>40-6C-T12</b>	6	40	300	65	33	19	4.85	12	50	
<b>50-6C-T14</b>	6	50	350	70	40	23.5	4.85	14	60	
<b>32-8C</b>	8	32	250	60	21.3	14.5	5.9	5.5	37	
<b>40-8C</b>	8	40	300	65	25.8	19.0	5.9	5.8	42	

Components • <sup>(1)</sup> Insert for grooving only  
 • Please check insert min. dia for internal grooving B49 page

TB31-TB32



## Internal turning, grooving and profiling

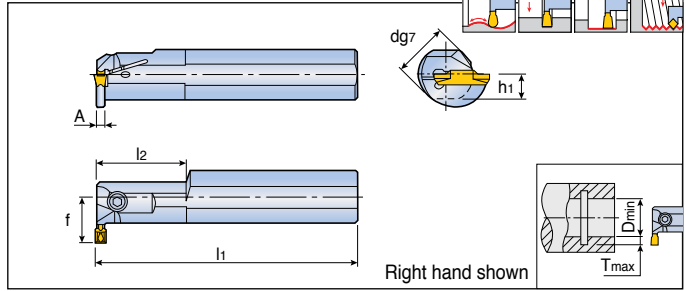

Designation	Insert seat size	Dimension (mm)								Insert
		d	l <sub>1</sub>	l <sub>2</sub>	f	h <sub>1</sub>	A	T <sub>max</sub>	D <sub>min</sub>	
<b>TTIR/L 16-2</b>	2	16	125	-	16.5	7.5	1.8	8.5	25	TDC <sup>(1)</sup> / J <sup>(1)</sup> / T
<b>20-2</b>	2	20	160	40	15.8	9.0	1.6	6.0	25	TDXU / XT /
<b>25-2</b>	2	25	200	40	17.5	11.5	1.6	5.0	25	FT / IT
<b>20-3</b>	3	20	160	40	15.8	9.0	2.1	6.0	25	TSC <sup>(1)</sup> / J <sup>(1)</sup>
<b>25-3</b>	3	25	200	40	17.5	11.5	2.1	5.1	25	B64-B74
<b>32-3</b>	3	32	250	60	19.8	14.0	2.1	4.7	31	
<b>20-4</b>	4	20	160	40	15.8	9.0	2.9	6.0	25	
<b>25-4</b>	4	25	200	40	17.5	11.5	2.9	5.2	25	
<b>32-4</b>	4	32	250	60	20.8	14.0	2.9	4.7	31	

- <sup>(1)</sup> Insert for grooving only
- Without "C" on the description: non-coolant hole type
- Please check insert min. dia for internal grooving B49 page

Machining	TDJ/C		TDT		TDT RU		TDXU	
	Size (mm)	Min. dia. (mm)	Size (mm)	Min. dia. (mm)	Size (mm)	Min. dia. (mm)	Size (mm)	Min. dia. (mm)
Internal grooving Min. dia. of internal machining	2	40	3	40	2	41	2	24
	3	50	4	40	3	38	3	24
	4	50	5	50	4	38	4	21
	5	60	6	50	5	43	5	30
	6	60	8	62	6	46	6	31
	8	70			8	56	8	33

## Spare parts

Designation	Screw	Wrench	Seal
<b>TTIR/L 16-2</b>	SH M5x0.8x10	L-W 4	PL 16 (M6)
<b>TTIR/L 20-2/3/4</b>	SH M5x0.8x12	L-W 4	PL 20 (M6)
<b>TTIR/L 25-2/3/4</b>	SH M5x0.8x16	L-W 4	PL 25 (R1/8")
<b>TTIR/L 32-3/4</b>	SH M5x0.8x16	L-W 4	PL 32 (R1/8")
<b>TTIR/L 40-3/4</b>	SH M5x0.8x16	L-W 4	PL 40 (R1/8")
<b>TTIR/L 50-4</b>	SH M5x0.8x20	L-W 4	PL 40 (R1/8")
<b>TTIR/L 25-5/6</b>	SH M6x1x16	L-W 5	PL 25 (R1/8")
<b>TTIR/L 32-5/6</b>	SH M6x1x20	L-W 5	PL 32 (R1/8")
<b>TTIR/L 40/50-5/6</b>	SH M6x1x25	L-W 5	PL 40 (R1/8")

Components



TB31-TB32

## Internal, grooving and turning on small diameter

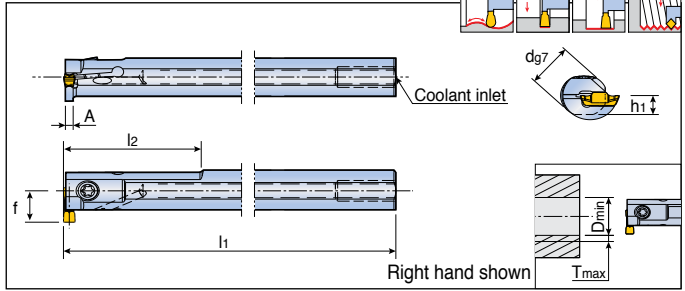
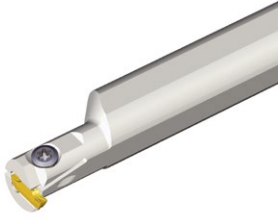

Designation	Insert seat size	Dimension (mm)								Coolant inlet	Insert
		d	l <sub>1</sub>	l <sub>2</sub>	f	h <sub>1</sub>	A	T <sub>max</sub>	D <sub>min</sub>		
<b>TTSIR/L 10-12.5-2</b>	2	10	125	25	7.5	4.5	1.6	2.4	12.5	Ø3.5	TDIM / TDIP B75, B76
<b>12-14-2</b>	2	12	125	35	9.1	5.5	1.6	2.6	14	Ø6	
<b>16-12.5-2</b>	2	16	150	20	10.5	7.5	1.6	2.4	12.5	-	
<b>16-14-2</b>	2	16	150	25	11.0	7.5	1.6	2.6	14	-	
<b>16-16-2</b>	2	16	150	40	11.0	7.5	1.6	3.0	16	-	
<b>12-14-3</b>	3	12	125	35	9.1	5.5	2.0	2.6	14	Ø6	
<b>16-12.5-3</b>	3	16	150	20	10.5	7.5	2.0	2.4	12.5	-	
<b>16-14-3</b>	3	16	150	25	11.0	7.5	2.0	2.6	14	-	
<b>16-16-3</b>	3	16	150	40	11.0	7.5	2.0	3.0	16	-	
<b>20-20-3</b>	3	20	150	40	14.0	9.0	2.0	4.0	20	-	

## Spare parts

Designation	Screw	Wrench	Seal	
<b>TTSIR/L 10/12</b>	TS 400931	T 15	-	
<b>TTSIR/L 16-12/14</b>	TS 400931	T 15	PL 16 (M6)	
<b>TTSIR/L 16-16</b>	TS 501251	T 20	PL 16 (M6)	
<b>TTSIR/L 20</b>	TS 501251	T 20	PL 20 (M6)	



## Internal shallow grooving and turning on small diameter

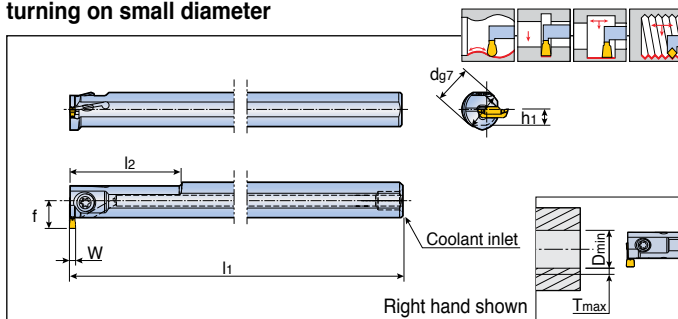

Designation	Insert seat size	Dimension (mm)								Coolant inlet	Insert
		d	l <sub>1</sub>	l <sub>2</sub>	f	h <sub>1</sub>	T <sub>max</sub>	D <sub>min</sub>	W		
<b>TGSIR/L 10-13-2</b>	2, 3	10	125	25	7.6	5	2.5	12.5	< 2	Ø3.5	TDIM / TDIP
<b>12-14-2</b>	2, 3	12	125	32	9.0	6	2.5	14.0	< 2	Ø6	B75, B76
<b>16-13-2</b>	2, 3	16	150	20	10.6	8	2.5	13.0	< 2	-	
<b>16-14-2</b>	2, 3	16	150	25	10.9	8	2.5	14.0	< 2	-	
<b>16-16-2</b>	2, 3	16	150	40	10.5	8	2.5	16.0	< 2	-	

## Spare parts

Designation	Screw	Wrench	Seal	
<b>TGSIR/L 10/12</b>	TS 40093I	T 15	-	
<b>TGSIR/L 16</b>	TS 40093I	T 15	PL 16 (M6)	



## External undercutting

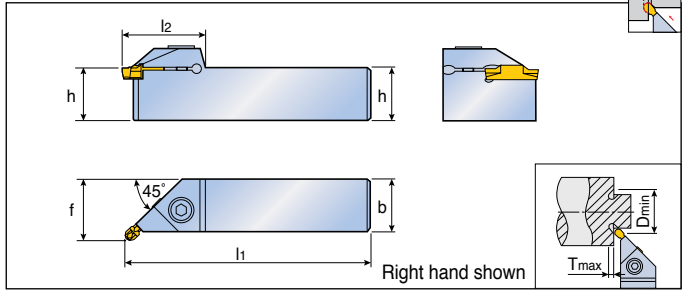
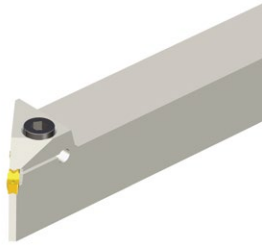

Designation	Insert seat size	Dimension (mm)								Insert
		h	b	l <sub>1</sub>	f	l <sub>2</sub>	T <sub>max</sub>	D <sub>min</sub>		
<b>TGEUR/L 1616-3</b>	2, 3	16	16	110	19.3	30	2.8	32	TDT / TDIT B69-B73	
<b>2020-3</b>	2, 3	20	20	125	23.3	30	2.8	32		
<b>2525-3</b>	2, 3	25	25	150	28.3	30	2.8	32		
<b>1616-4</b>	4	16	16	110	19.5	31	2.8	32		
<b>2020-4</b>	4	20	20	125	23.5	31	2.8	32		
<b>2525-4</b>	4	25	25	150	28.5	31	2.8	32		
<b>2525-6</b>	5, 6	25	25	150	28.9	35	3.4	34		

## Spare parts

Designation	Screw	Wrench		
<b>TGEUR/L 1616-3</b>	SH M5x0.8x16	L-W4		
<b>TGEUR/L 2020-3</b>	SH M5x0.8x20	L-W4		
<b>TGEUR/L 2525-3</b>	SH M5x0.8x25	L-W4		
<b>TGEUR/L 1616-4</b>	SH M6x1x16	L-W5		
<b>TGEUR/L 2020-4</b>	SH M6x1x20	L-W5		
<b>TGEUR/L 2525-4/6</b>	SH M6x1x25	L-W5		

Components



TB31-TB32

## Internal undercutting

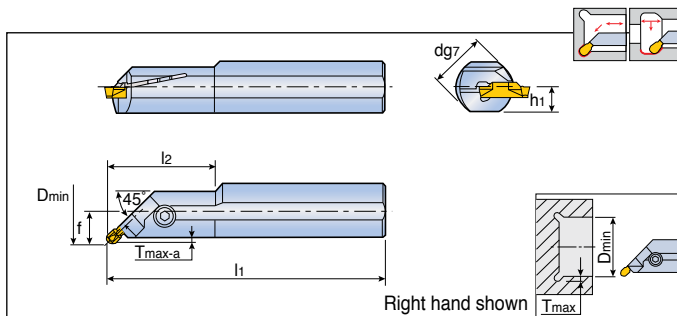

Designation	Insert seat size	Dimension (mm)								Insert
		d	l1	l2	f	h1	Tmax-a	Dmin		
<b>TGIUR/L 20-3</b>	2, 3	20	160	-	12.8	9.5	2.8	38	TDT / TDIT B69-B73	
<b>25-3</b>	2, 3	25	200	40	14.8	11.5	2.8	38		
<b>20-4</b>	4	20	160	-	12.9	9.5	2.8	38		
<b>25-4</b>	4	25	200	40	14.9	11.5	2.8	46		
<b>25-6</b>	5, 6	25	200	-	15.2	11.5	2.8	46		

## Spare parts

Designation	Screw	Wrench		
<b>TGIUR/L 20-3</b>	SH M5x0.8x12	L-W4		
<b>TGIUR/L 20-4</b>	SH M5x0.8x16	L-W4		
<b>TGIUR/L 25-3/4</b>	SH M5x0.8x16	L-W4		
<b>TGIUR/L 25-6</b>	SH M6x1x16	L-W5		



## Aluminum wheel machining

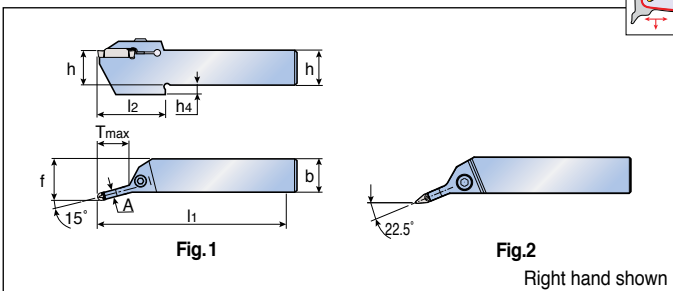

Designation	Insert seat size	Dimension (mm)								Fig.	Insert
		h	b	l1	f	l2	A	h4	Tmax		
<b>TTER/L 2525-6-15A</b>	6	25	25	150	30	51	4.9	7	25.0	1	TDA / TSA
<b>2525-8-15A</b>	8	25	25	150	30	55	5.9	7	30.0	1	B77
<b>2525-8V-22.5A*</b>	8	25	25	150	31.7	45	5.85	7	22.0	2	

\* For TDA-35V insert

## Spare parts

Designation	Screw	Wrench		
<b>TTER/L</b>	SH M6x1x25	L-W5		



## Aluminum wheel machining

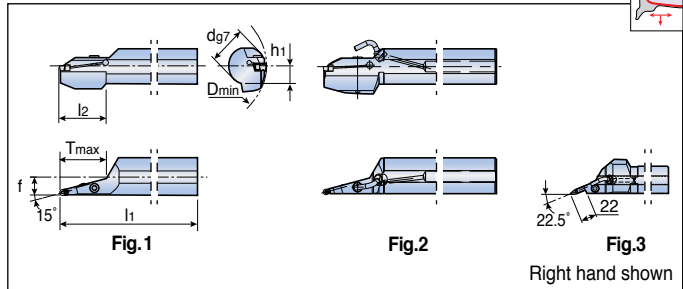

Designation	Insert seat size	Dimension (mm)							Fig.	Coolant	Insert
		d	l1	l2	f	h1	Tmax	Dmin			
<b>TGIUR/L40-6-15A</b>	6	40	320	60	19.8	19.0	50.00	160	1	External	TDA / TSA B77
<b>40-6C-15A</b>	6	40	320	60	19.8	19.0	50.00	160	2	Internal	
<b>50-6C-15A</b>	6	50	350	85	25.2	23.5	85.00	200	2	Internal	
<b>40-8-15A</b>	8	40	320	65	20.2	19.0	81.35	160	1	External	
<b>40-8C-15A</b>	8	40	320	85	20.2	19.0	83.00	160	2	Internal	
<b>50-8C-15A</b>	8	50	350	85	25.9	23.5	85.00	200	2	Internal	
<b>40-8VC-22.5A*</b>	8	40	320	85	19.3	19.0	35.00	160	3	Internal	

\* For TDA-35V insert

## Spare parts

Designation	Screw	Wrench	Seal	Coolant pipe	Coolant nozzle
<b>TGIUR/L</b>	SH M6x1x25	L-W5	PL 40 (R1/8")	NZP5	NZ125



## Semi finished holder for TGUX insert

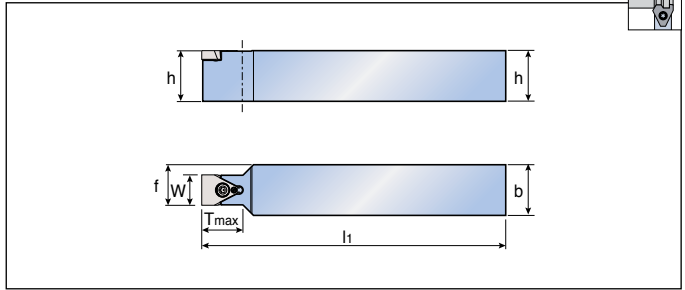

Designation	Dimension (mm)						Insert <sup>(1)</sup>	
	h	b	f	T <sub>max</sub>	l <sub>1</sub>	W		
<b>TTLEN 1212 K10</b>	12	12	11	20	125	10	TGUX B78	
<b>1616 K10</b>	16	16	13	20	125	10		
<b>2020 M10</b>	20	20	15	20	150	10		
<b>2525 M10</b>	25	25	17.5	20	150	10		
<b>1616 K15</b>	16	16	15.5	20	125	15		
<b>2020 M15</b>	20	20	17.5	20	150	15		
<b>2525 M15</b>	25	25	20	20	150	15		
<b>2020 K20</b>	20	20	20	35	125	20		
<b>2525 M20</b>	25	25	22.5	35	150	20		
<b>3232 P20</b>	32	32	26	35	170	20		
<b>2020 K25</b>	20	20	22.5	35	125	25		
<b>2525 M25</b>	25	25	25	35	150	25		
<b>3232 P25</b>	32	32	28.5	35	170	25		

<sup>(1)</sup> Designation of final insert will be different to the semi finished blank

## Spare parts

Designation	Screw	Wrench		
<b>TTLEN ...K10/K15/M10/M15</b>	TS 40B100I	T15		
<b>TTLEN ...K20/M20/P20</b>	TS 45120I	T20		
<b>TTLEN ...K25/M25/P25</b>	TS 45120I	T20		

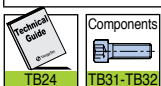



## Holders for grooving, parting, turning & reverse turning

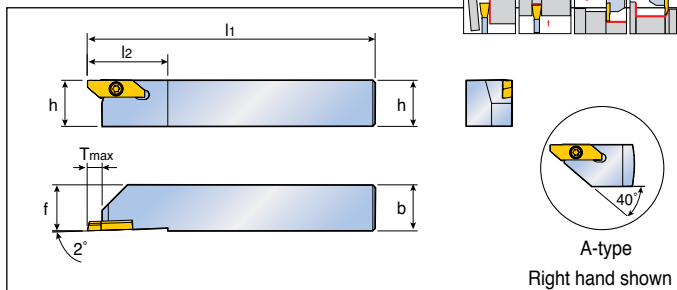
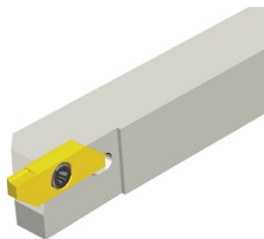

Designation	Dimension (mm)						Insert
	h	b	l <sub>1</sub>	l <sub>2</sub>	T <sub>max</sub>	f	
<b>TTVER/L 1010-4-A</b>	10	10	125	29	6.7	9.9	TVER/L
<b>1212-4-A</b>	12	12	125	29	6.7	11.9	TVRR/L
<b>1616-4</b>	16	16	125	29	6.5	15.9	TVPR/L
<b>2020-4</b>	20	20	125	29	6.5	19.9	B92, B94
<b>2525-4</b>	25	25	125	29	6.5	24.9	

## Spare parts

Designation	Screw	Wrench		
<b>TTVER/L</b>	 CSTB-4SD	 T 8		

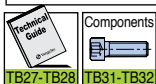

## Holders for threading & back turning

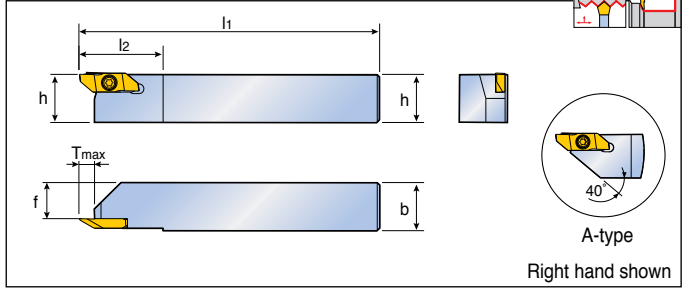
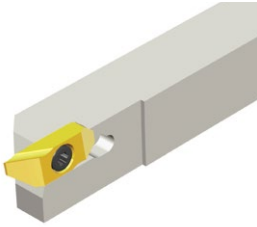

Designation	Dimension (mm)						Insert
	h	b	l <sub>1</sub>	l <sub>2</sub>	T <sub>max</sub>	f	
<b>TTVBR/L 1010-4-A</b>	10	10	125	29	6.7	5.7	TVBR/L TVTR/L B93
<b>1212-4-A</b>	12	12	125	29	6.7	7.7	
<b>1616-4</b>	16	16	125	29	6.4	11.7	
<b>2020-4</b>	20	20	125	29	6.4	15.7	
<b>2525-4</b>	25	25	125	29	6.4	20.7	

## Spare parts

Designation	Screw	Wrench		
<b>TTVER/L</b>	CSTB-4SD	T 8		
<b>TTVBR/L</b>	CSTB-4SD	T 8		

Technical Guide  
TB27-TB28

Components  
TB31-TB32

# TQHR/L

## Integral shank toolholders

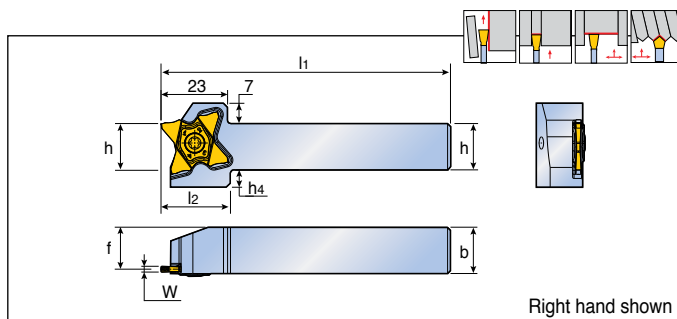

Designation	Dimension (mm)							Insert
	h	b	W <sub>range</sub>	f <sup>(2)</sup>	l <sub>1</sub>	l <sub>2</sub>	h <sub>4</sub>	
<b>TQHR/L 10-27</b>	10	10	$0.5 \leq W < 5.3$	8.5	120	24	9	TQ.. 27
<b>12-27</b>	12	12	$0.5 \leq W < 5.3$	10.5	120	24	8	B96-B102
<b>16-27</b>	16	16	$0.5 \leq W < 5.3$	14.5	120	24	6	
<b>20-27</b>	20	20	$0.5 \leq W < 5.3$	18.5	120	24	2	
<b>25-27</b>	25	25	$0.5 \leq W < 5.3$	23.5	135	-	-	
<b>16-27-8<sup>(1)</sup></b>	16	16	$5.3 \leq W \leq 8.2$	14.0	120	24	6	TQS 27
<b>20-27-8<sup>(1)</sup></b>	20	20	$5.3 \leq W \leq 8.2$	18.0	120	24	2	B102
<b>25-27-8<sup>(1)</sup></b>	25	25	$5.3 \leq W \leq 8.2$	23.0	135	-	-	

- <sup>(1)</sup> Only for TQS wider inserts from 5.3mm-8.2mm width
- <sup>(2)</sup> " f " value is based on TQ.. 27 standard insert

## Spare parts

Designation	Screw	Wrench		
<b>TQHR/L 10/12/16/20/25</b>	TS 50125I <sup>(1)</sup>	T 10/20		
	TS 50125IL <sup>(2)</sup>	T 10/20		
<b>TQHR/L16/20/25-27-8</b>	TS 501701I-IC <sup>(3)</sup>	T 15		
	TS 501701IL-IC <sup>(4)</sup>	T 15		

Cutting Condition  
 Precision Blade  
 Components

- <sup>(1)</sup>/<sup>(3)</sup> For left holder
- <sup>(2)</sup>/<sup>(4)</sup> For right holder

## Perpendicular integral shank toolholders

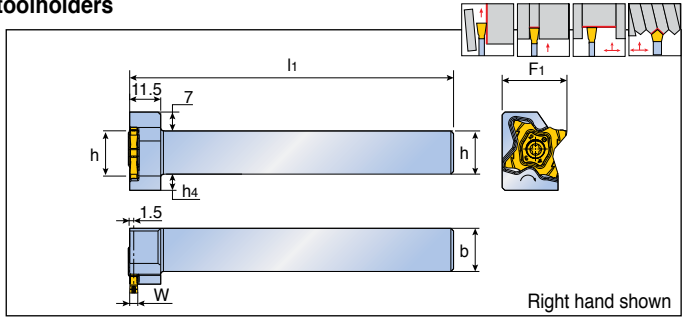

Designation	Dimension (mm)						Insert
	h	b	Wrange	F1	l1	h4	
<b>TQHPR/L 16-27</b>	16	16	$0.5 \leq W < 5.3$	24	120	6	TQ.. 27
<b>20-27</b>	20	20	$0.5 \leq W < 5.3$	28	120	2	B96-B102
<b>25-27</b>	25	25	$0.5 \leq W < 5.3$	33	135	-	
<b>16-27-8 <sup>(1)</sup></b>	16	16	$5.3 \leq W \leq 8.2$	24	120	6	TQS 27
<b>20-27-8 <sup>(1)</sup></b>	20	20	$5.3 \leq W \leq 8.2$	28	120	2	B102
<b>25-27-8 <sup>(1)</sup></b>	25	25	$5.3 \leq W \leq 8.2$	33	135	-	

• <sup>(1)</sup> Only for TQS wider inserts from 5.3mm-8.2mm width

## Spare parts

Designation	Screw	Wrench		
<b>TQHPR/L 16/20/25</b>	TS 501251 <sup>(1)</sup>	T 20		
	TS 501251L <sup>(2)</sup>	T 20		
<b>TQHPR/L 16/20/25-8</b>	TS 501701-IC <sup>(3)</sup>	T 15		
	TS 501701IL-IC <sup>(4)</sup>	T 15		

 Cutting Condition B113	 Technical Guide TB28	 Components TB31-TB32
-------------------------------	-----------------------------	-----------------------------

• <sup>(1)(3)</sup> For right holder • <sup>(2)(4)</sup> For left holder

# Parting & Grooving Inserts and Solid Bars

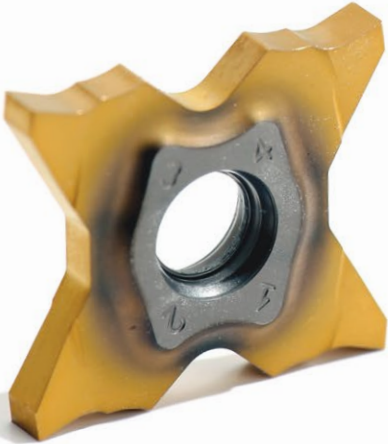

# Insert Designation System

## Parting and grooving



### 1 TaeguTec

### 2 Cutting edge type

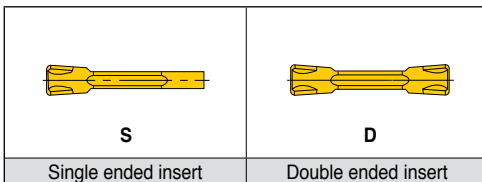

### 3 Chip breaker type

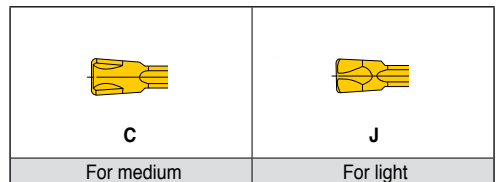

### 4 Width of insert

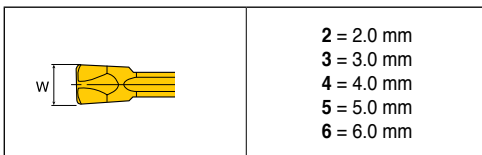

### 5 Lead angle

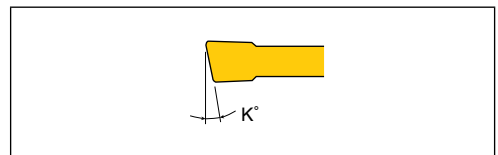

### 6 Hand of insert

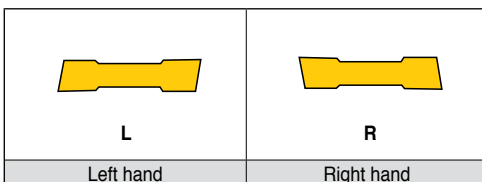

### 7 Corner type

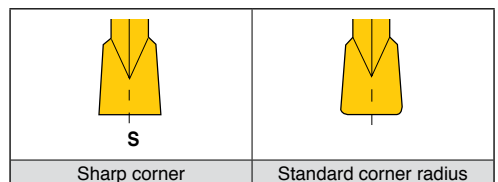

# Insert Designation System



Turning, grooving and face machining

**T** **D** **(F)** **T** **3.00** **E** - **0.40** **R**

1 2 3 4 5 6 7 8

## 1 TaeguTec

### 2 Cutting edge type

	
<b>S</b>	<b>D</b>
Single ended insert	Double ended insert

### 3 Application type

<b>F</b>	Face turning and grooving
<b>I</b>	Internal turning and grooving
<b>X</b>	Universal

### 4 Chip breaker type

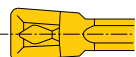
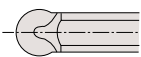
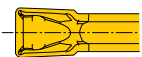
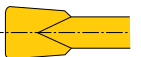
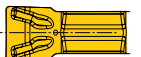
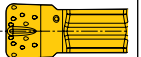
					
<b>T</b>	<b>A</b>	<b>U</b>	<b>G</b>	<b>M</b>	<b>P</b>
For steel, high-temp. alloy and cast iron	For aluminum	Universal chip breaker	Without chip breaker	Pressed for small diameter	Ground for small diameter

### 5 Width of insert (mm)

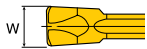
	<input type="checkbox"/> . <input type="checkbox"/> . <input type="checkbox"/> Precision insert
	<input type="checkbox"/> Pressed insert



### 6 Application type

<b>E</b>	For turning and grooving
<b>No designation</b>	For precision grooving

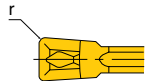
### 7 Corner radius (mm)

	<input type="checkbox"/> . <input type="checkbox"/> Precision insert
	<input type="checkbox"/> Pressed insert

### 8 Hand of insert - For face machining

	
<b>L</b>	<b>R</b>
Left hand insert on left hand holder	Right hand insert on right hand holder

## Double ended inserts for parting and grooving with "C" type chip breaker

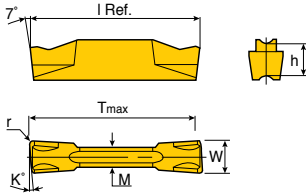

Right hand shown

Size	Dimension (mm)						
	W±0.05	r	M	l	K	h	Tmax
<b>2 (.R/L)</b>	2.0	0.20	1.7	20.0	0-15	4.7	19
<b>2 RS/LS</b>	2.0	0.02	1.7	19.6	15	4.7	19
<b>3 (.R/L)</b>	3.0	0.20	2.4	20.0	0-15	4.7	19
<b>3 RS/LS</b>	3.0	0.02	2.4	19.6	6-15	4.7	19
<b>4 (.R/L)</b>	4.0	0.30	3.0	20.0	0-15	4.7	19
<b>5 (.R/L)</b>	5.0	0.30	4.0	25.0	0-4	5.2	24
<b>6</b>	6.0	0.30	5.0	25.0	-	5.2	24
<b>8</b>	8.0	0.40	6.0	30.0	-	6.4	29

Insert	Designation	Insert seat size	Feed (mm/rev)	Cermet		Coated				Uncoated			
				PV3030	CT3000	TT6300	TT6080	TT5100	TT9080	TT7220	TT8020	K10	
	<b>TDC 2</b>	2	0.05-0.18	●	●					●	●	●	●
	<b>2-6R/L</b>	2	0.04-0.14							●	●	●	●
	<b>2-8R/L</b>	2	0.04-0.14							●	●		
	<b>2-15R/L</b>	2	0.04-0.12							●	●		
	<b>2-15RS/LS</b>	2	0.02-0.12							●	●		
	<b>3</b>	3	0.07-0.25	●	●					●	●	●	●
	<b>3-6R/L</b>	3	0.06-0.18							●	●		●
	<b>3-6RS/LS</b>	3	0.03-0.18							●			
	<b>3-15R/L</b>	3	0.06-0.16							●	●		
	<b>3-15RS/LS</b>	3	0.03-0.16							●	●		
	<b>4</b>	4	0.08-0.30		●					●	●	●	●
	<b>4-4R/L</b>	4	0.06-0.24							●	●		●
	<b>4-15R/L</b>	4	0.06-0.22							●	●		
	<b>5</b>	5	0.09-0.35							●	●	●	●
	<b>5-4R/L</b>	5	0.07-0.28							●	●		●
<b>6</b>	6	0.12-0.40							●	●	●	●	
<b>8</b>	8	0.14-0.43							●	●			

●: Standard item

### Dmax (mm) for parting & grooving

Insert	Dmax (mm)
<b>TDC 2-15 RS/LS</b>	28
<b>TDC 3-15 RS/LS</b>	29
<b>TDC 4-5 R/L</b>	30

- Standard holders (except TGFR xxxx) will be damaged if workpiece diameter goes over the dimension of each insert in the table.





## Single ended inserts for deep grooving and parting with "C" type chip breaker

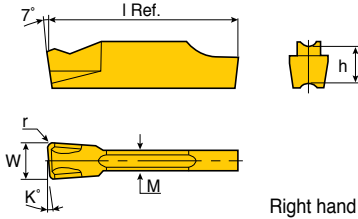

Size	Dimension (mm)					
	W±0.05	r	M	I	K	h
<b>2 (.R/L)</b>	2.0	0.20	1.7	20.0	0-15	4.7
<b>2 RS/LS</b>	2.0	0.02	1.7	19.6	15	4.7
<b>3 (.R/L)</b>	3.0	0.20	2.4	20.0	0-15	4.7
<b>3 RS/LS</b>	3.0	0.02	2.4	19.6	15	4.7
<b>4 (.R/L)</b>	4.0	0.30	3.0	20.0	0-15	4.7
<b>5 (.R/L)</b>	5.0	0.30	4.0	25.0	0-4	5.2
<b>6</b>	6.0	0.30	5.0	25.0	-	5.2
<b>8</b>	8.0	0.40	6.0	30.0	-	6.4

Insert	Designation	Insert seat size	Feed (mm/rev)	Cermet			Coated			Uncoated				
				PV3030	CT3000		TT6300	TT6080	TT5100	TT9080	TT7220	TT8020	K10	
	<b>TSC 2</b>	2	0.05-0.18						●	●	●	●		
	<b>2-6R/L</b>	2	0.04-0.14							●	●	●		
	<b>2-8R/L</b>	2	0.04-0.14							●	●			
	<b>2-15R/L</b>	2	0.04-0.12							●	●			
	<b>2-15RS/LS</b>	2	0.02-0.12							●	●			
	<b>3</b>	3	0.07-0.25						●	●	●	●		
	<b>3-6R/L</b>	3	0.06-0.18							●	●	●	●	
	<b>3-15R/L</b>	3	0.06-0.16							●	●			
	<b>3-15RS/LS</b>	3	0.03-0.16							●	●			
	<b>4</b>	3	0.08-0.30						●	●	●			
	<b>4-4R/L</b>	4	0.06-0.24						●	●	●	●		
	<b>4-6R/L</b>	4	0.06-0.23							●		●		
	<b>4-15R/L</b>	4	0.06-0.22							●	●			
	<b>5</b>	5	0.09-0.35						●	●	●	●		
	<b>5-4R/L</b>	5	0.07-0.28							●	●			
<b>6</b>	6	0.12-0.40						●	●	●	●			
<b>8</b>	8	0.14-0.43						●		●				

● Standard item

**Dmax (mm) for parting & grooving**

Insert	Dmax (mm)
<b>TSC 3-15 R/L</b>	96

• Standard holders (except TGFR xxxx) will be damaged if workpiece diameter goes over the dimension of each insert in the table.



## Double ended inserts for parting and grooving with "J" type chip breaker

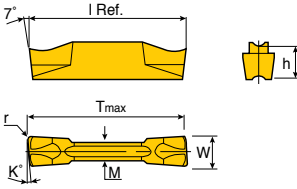

Right hand shown

Size	Dimension (mm)						
	W±0.05	r	M	l	K	h	Tmax
<b>1.4</b>	1.4	0.16	1.0	16.0	-	4.0	15
<b>2 (.R/L)</b>	2.0	0.20	1.7	20.0	0-15	4.7	19
<b>2 RS/LS</b>	2.0	0.02	1.7	19.6	6-15	4.7	19
<b>3 (.R/L)</b>	3.0	0.20	2.4	20.0	0-15	4.7	19
<b>3 RS/LS</b>	3.0	0.02	2.4	19.6	6-15	4.7	19
<b>4 (.R/L)</b>	4.0	0.30	3.0	20.0	0-15	4.7	19
<b>5 (.R/L)</b>	5.0	0.30	4.0	25.0	0-4	5.2	24
<b>6</b>	6.0	0.30	5.0	25.0	-	5.2	24

Insert	Designation	Insert seat size	Feed (mm/rev)	Cermet			Coated				Uncoated		
				PV3030	CT3000		TT6300	TT6080	TT5100	TT9080	TT7220	TT8020	K10
	<b>TDJ 1.4</b>	1	0.02-0.10						●		●		
	<b>2</b>	2	0.04-0.12						●	●	●		
	<b>2-6R/L</b>	2	0.03-0.08							●	●	●	
	<b>2-6RS/LS</b>	2	0.03-0.07							●	●	●	
	<b>2-8R/L</b>	2	0.03-0.08							●	●		
	<b>2-15R/L</b>	2	0.03-0.08							●	●		
	<b>2-15RS/LS</b>	2	0.03-0.07							●	●		
	<b>3</b>	3	0.04-0.16		●				●	●	●	●	
	<b>3-6R/L</b>	3	0.03-0.12							●	●	●	
	<b>3-6RS/LS</b>	3	0.03-0.10							●	●		
	<b>3-15R/L</b>	3	0.03-0.12							●	●		
	<b>3-15RS/LS</b>	3	0.03-0.10							●	●		
	<b>4</b>	4	0.05-0.18						●	●	●	●	
	<b>4-4R/L</b>	4	0.05-0.14							●	●	●	
	<b>4-15R/L</b>	4	0.05-0.12							●	●	●	
	<b>5</b>	5	0.05-0.20						●	●	●	●	
<b>5-4R/L</b>	5	0.05-0.16							●	●	●		
<b>6</b>	6	0.05-0.22						●	●	●	●		

●: Standard item

### Dmax (mm) for parting & grooving

Insert	Dmax (mm)
<b>TDJ 2-15 RS/LS</b>	28
<b>TDJ 3-15 RS/LS</b>	29
<b>TDJ 4-15 R/L</b>	30

- Standard holders (except TGFR xxxx) will be damaged if workpiece diameter goes over the dimension of each insert in the table.



## Single ended inserts for deep grooving and parting with "J" type chip breaker

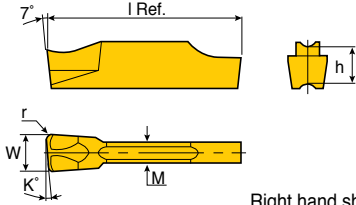

Size	Dimension (mm)					
	W±0.05	r	M	I	K	h
<b>2 (.R/L)</b>	2.0	0.20	1.7	20.0	0-15	4.7
<b>2 RS/LS</b>	2.0	0.02	1.7	19.8	15	4.7
<b>3 (.R/L)</b>	3.0	0.20	2.4	20.0	0-15	4.7
<b>3 RS/LS</b>	3.0	0.02	2.4	19.8	6-15	4.7
<b>4 (.R/L)</b>	4.0	0.30	3.0	20.0	0-6	4.7
<b>5 (.R/L)</b>	5.0	0.30	4.0	25.0	0-4	5.2
<b>6</b>	6.0	0.30	5.0	25.0	-	5.2

Insert	Designation	Insert seat size	Feed (mm/rev)	Cermet			Coated			Uncoated			
				PV3030	CT3000		TT6300	TT6080	TT5100	TT9080	TT7220	TT8020	K10
	<b>TSJ 2</b>	2	0.04-0.12						●	●	●	●	
	<b>2-6R/L</b>	2	0.03-0.08							●	●	●	
	<b>2-15R/L</b>	2	0.03-0.08							●	●		
	<b>2-15RS/LS</b>	2	0.03-0.08							●	●		
	<b>2-8R/L</b>	2	0.03-0.07							●	●		
	<b>3</b>	3	0.04-0.16						●	●	●	●	
	<b>3-6R/L</b>	3	0.03-0.12							●	●	●	
	<b>3-6RS/LS</b>	3	0.03-0.10							●	●	●	
	<b>3-15R/L</b>	3	0.03-0.12							●	●		
	<b>3-15RS/LS</b>	3	0.03-0.10							●	●		
	<b>4</b>	4	0.05-0.18						●	●	●	●	
	<b>4-4R/L</b>	4	0.05-0.14							●	●	●	
	<b>4-6R/L</b>	4	0.05-0.12							●			
	<b>5</b>	5	0.05-0.20						●	●	●	●	
	<b>5-4R/L</b>	5	0.05-0.16							●	●		
	<b>6</b>	6	0.05-0.22						●	●	●	●	

●: Standard item

**Dmax (mm) for parting & grooving**

Insert	Dmax (mm)
<b>TSJ 3-15 R/L</b>	103
<b>TSJ 3-15 RS/LS</b>	34

• Standard holders (except TGFR xxxx) will be damaged if workpiece diameter goes over the dimension of each insert in the table.



## Pressed inserts for external, internal, face turning, grooving and parting

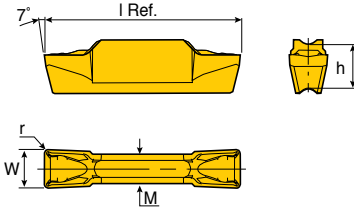

Size	Dimension (mm)				
	W±0.05	r	M	l	h
<b>2E-0.3</b>	2.0	0.3	1.7	20.0	4.7
<b>3E-0.3</b>	3.0	0.3	2.2	20.0	4.7
<b>4E-0.4</b>	4.0	0.4	3.0	20.0	4.7
<b>4E-0.8</b>	4.0	0.8	3.0	20.0	4.7
<b>5E-0.4</b>	5.0	0.4	4.0	25.0	5.2
<b>5E-0.8</b>	5.0	0.8	4.0	25.0	5.2
<b>6E-0.4</b>	6.0	0.4	5.0	25.0	5.2
<b>6E-0.8</b>	6.0	0.8	5.0	25.0	5.2
<b>8E-0.8</b>	8.0	0.8	6.0	30.0	6.4

Insert	Designation	Insert seat size	Turning		Grooving	Cermet		Coated				Uncoated		
			Feed (mm/rev)	ap (mm)	Feed (mm/rev)	PV3030	CT3000	TT6300	TT6080	TT5100	TT9080	TT7220	TT8020	K10
	<b>TDXU 2E-0.3</b>	2	0.12-0.18	0.4-1.2	0.03-0.18			●	●	●	●	●	●	
	<b>3E-0.3</b>	3	0.15-0.19	0.4-1.8	0.07-0.11	●	●	●	●	●	●	●	●	
	<b>4E-0.4</b>	4	0.18-0.24	0.5-2.4	0.09-0.15	●	●	●	●	●	●	●	●	
	<b>4E-0.8</b>	4	0.18-0.24	1.0-2.4	0.09-0.15		●	●	●	●	●	●	●	
	<b>5E-0.4</b>	5	0.20-0.30	0.5-3.0	0.11-0.20		●	●	●	●	●	●	●	
	<b>5E-0.8</b>	5	0.23-0.35	1.0-3.0	0.11-0.21		●	●	●	●	●	●	●	
	<b>6E-0.4</b>	6	0.22-0.36	0.1-0.4	0.13-0.23			●	●	●	●	●	●	
	<b>6E-0.8</b>	6	0.24-0.42	1.0-3.6	0.13-0.25			●	●	●	●	●	●	
<b>8E-0.8</b>	8	0.30-0.56	1.0-4.8	0.15-0.34			●	●	●	●	●	●		



●: Standard item

# TDXT-E

## Pressed inserts for external, internal, face turning and grooving

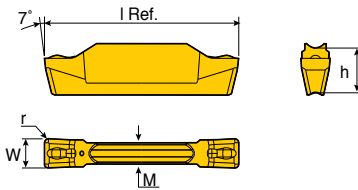

Size	Dimension (mm)				
	W±0.05	r	M	l	h
<b>3E-0.4</b>	3.0	0.4	2.2	20.0	4.7
<b>4E-0.4</b>	4.0	0.4	3.0	20.0	4.7
<b>5E-0.4</b>	5.0	0.4	4.0	25.0	5.2
<b>6E-0.8</b>	6.0	0.8	5.0	25.0	5.2
<b>8E-0.8</b>	8.0	0.8	6.0	30.0	6.4

Insert	Designation	Insert seat size	Turning		Grooving	Cermet		Coated				Uncoated		
			Feed (mm/rev)	ap (mm)	Feed (mm/rev)	PV3030	CT3000	TT6300	TT6080	TT5100	TT9080	TT7220	TT8020	K10
	<b>TDXT 3E-0.4</b>	3	0.15-0.22	0.5-1.8	0.07-0.15			●	●	●	●	●	●	
	<b>4E-0.4</b>	4	0.18-0.30	0.5-2.4	0.09-0.18		●	●	●	●	●	●	●	
	<b>5E-0.4</b>	5	0.20-0.35	0.5-3.0	0.11-0.20			●	●	●	●	●	●	
	<b>6E-0.8</b>	6	0.24-0.42	1.0-3.6	0.13-0.30			●	●	●	●	●	●	
	<b>8E-0.8</b>	8	0.30-0.56	1.0-4.8	0.15-0.40			●	●	●	●	●	●	



●: Non-standard grade production available at the customer's request

●: Standard item

## Precision inserts for external grooving only

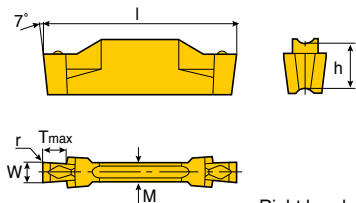

Size	Dimension (mm)					
	W±0.02	r±0.05	M	l	Tmax	h
<b>1.00</b>	1.00	0.00	2.2	20.0	2.5	4.7
<b>1.30</b>	1.30	0.00	2.2	20.0	2.5	4.7
<b>1.60</b>	1.60	0.10	2.2	20.0	2.5	4.7
<b>1.85</b>	1.85	0.10	2.2	20.0	3.5	4.7
<b>2.15</b>	2.15	0.15	2.2	20.0	3.5	4.7

Insert	Designation	Insert seat size	Grooving	Cermet		Coated					Uncoated	
			Feed (mm/rev)	PV3030	CT3000	TT6300	TT6080	TT5100	TT9080	TT7220	TT8020	K10
	<b>TDT 1.00-0.00*</b>	2	0.02-0.04						●	●	●	
	<b>1.30-0.00*</b>	2	0.02-0.05						●	●	●	
	<b>1.60-0.10*</b>	2	0.03-0.07						●	●	●	
	<b>1.85-0.10*</b>	2	0.03-0.09						●	●	●	
	<b>2.15-0.15</b>	2	0.03-0.10						●	●	●	



• \*: Not for standard holder & only for grooving

●: Standard item

# TDT-E

## Pressed inserts for external turning and grooving

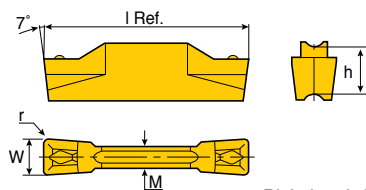

Size	Dimension (mm)					
	W±0.05	r	M	l	h	
<b>3</b>	3.0	0.4	2.2	20.0	4.7	
<b>4</b>	4.0	0.4	3.0	20.0	4.7	
<b>6</b>	6.0	0.8	5.0	25.0	5.2	

Insert	Designation	Insert seat size	Turning		Grooving	Cermet			Ceramic			Coated					Uncoated
			Feed (mm/rev)	ap (mm)	Feed (mm/rev)	PV3030	CT3000	AB30		TT6300	TT6080	TT5100	TT9080	TT7220	TT8020	K10	
	<b>TDT 3E-0.4</b>	3	0.15-0.22	0.5-1.8	0.07-0.15		●				●	●	●	●	●	●	●
	<b>4E-0.4</b>	4	0.18-0.30	0.5-2.4	0.09-0.18		●				●	●	●	●	●	●	●
	<b>4E-0.4T CE<sup>(1)</sup></b>	4	0.18-0.30	0.5-2.4	0.09-0.35			●									
	<b>6E-0.8T CE<sup>(1)</sup></b>	6	0.24-0.42	1.0-3.6	0.13-0.40			●									



• <sup>(1)</sup>This insert is a pressed ceramic insert

●: Standard item

## Precision inserts for external turning and grooving

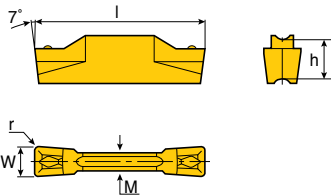

Size	Dimension (mm)				
	W±0.02	r	M	l	h
<b>2.65 / 3.00 / 3.15</b>	2.65-3.15	0.15-0.40	2.2	20.0	4.7
<b>4.00 / 4.15</b>	4.00-4.15	0.15-0.80	3.0	20.0	4.7
<b>4.78 / 5.00 / 5.15</b>	4.78-5.15	0.15-0.80	4.0	25.0	5.2
<b>6.00</b>	6.00	0.80-1.20	5.0	25.0	5.2
<b>8.00</b>	8.00	0.80-1.20	6.0	30.0	6.4
<b>10.00</b>	10.00	0.80-2.00	8.0	30.0	6.4

Insert	Designation	Insert seat size	Turning		Grooving	Cermet		Coated					Uncoated
			Feed (mm/rev)	ap (mm)	Feed (mm/rev)	PV3030	CT3000	TT6300	TT6080	TT15100	TT9080	TT7220	TT8020
	<b>TDT 2.65E-0.15</b>	3	0.10-0.18	0.2-1.8	0.05-0.12				●	●	●	●	
	<b>3.00E-0.20</b>	3	0.12-0.20	0.3-0.2	0.07-0.13				●	●	●	●	
	<b>3.00E-0.40</b>	3	0.15-0.22	0.5-0.2	0.07-0.15				●	●	●	●	
	<b>3.15E-0.15</b>	3	0.15-0.22	0.2-0.2	0.07-0.15				●	●	●	●	
	<b>4.00E-0.40</b>	4	0.18-0.30	0.5-2.4	0.09-0.18				●	●	●	●	
	<b>4.00E-0.80</b>	4	0.18-0.30	1.0-2.4	0.09-0.18				●	●	●	●	
	<b>4.15E-0.15</b>	4	0.18-0.30	0.5-2.4	0.09-0.18				●	●	●	●	
	<b>4.78E-0.55</b>	5	0.20-0.35	0.7-2.8	0.10-0.20				●	●	●	●	
	<b>5.00E-0.40</b>	5	0.20-0.35	0.5-2.3	0.11-0.20				●	●	●	●	
	<b>5.00E-0.80</b>	5	0.23-0.35	1.0-3.0	0.11-0.21				●	●	●	●	
	<b>5.15E-0.15</b>	5	0.23-0.35	0.2-3.0	0.11-0.21				●	●	●	●	
	<b>6.00E-0.80</b>	6	0.24-0.42	1.0-3.6	0.13-0.30				●	●	●	●	
	<b>6.00E-1.20</b>	6	0.24-0.42	1.3-3.6	0.13-0.30				●	●	●	●	
	<b>8.00E-0.80</b>	8	0.30-0.56	1.0-4.8	0.15-0.40				●	●	●	●	
	<b>8.00E-1.20</b>	8	0.30-0.56	1.3-4.8	0.15-0.40				●	●	●	●	
	<b>10.00E-0.80</b>	10	0.35-0.65	1.0-6.0	0.20-0.45				●				
<b>10.00E-1.20</b>	10	0.40-0.80	1.0-6.0	0.20-0.45				●	●				
<b>10.00E-2.00</b>	10	0.35-0.80	1.0-6.0	0.20-0.45				●	●				

●: Standard item









## Pressed inserts for face grooving and turning

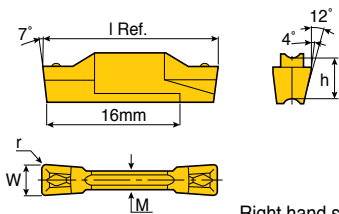

Size	Dimension (mm)				
	W±0.05	r	M	l	h
<b>3E</b>	3.0	0.40	2.2	20.0	4.7
<b>4E</b>	4.0	0.40	3.0	20.0	4.7
<b>4E... CE</b>	4.0	0.40	3.0	20.0	4.7

Insert	Designation	Insert seat size	Turning		Grooving	Cermet			Coated				Uncoated		
			Feed (mm/rev)	ap (mm)	Feed (mm/rev)	PV3030	CT3000	AB30	TT6300	TT6080	TT5100	TT9080	TT7220	TT8020	K10
	<b>TDFT 3E-0.4R/L</b>	3	0.15-0.22	0.5-0.2	0.07-0.15									●	●
	<b>4E-0.4R/L</b>	4	0.18-0.30	0.5-2.4	0.09-0.18									●	●
	<b>4E-0.4TR/L CE<sup>(1)</sup></b>	4	0.18-0.30	0.5-2.4	0.09-0.35			●							



- Apply R insert on R tool and L insert on L tool
- <sup>(1)</sup> This insert is a pressed ceramic insert

● Standard item

# TDIT-E (Full-Radius)

## Precision inserts for internal turning, grooving, profiling and undercutting

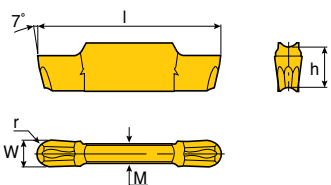

Size	Dimension (mm)				
	W±0.02	r±0.05	M	l	h
<b>3</b>	3.00	1.50	2.2	20.0	4.7
<b>4</b>	4.00	2.00	3.0	20.0	4.7
<b>5</b>	5.00	2.50	4.0	25.0	5.2
<b>6</b>	6.00	3.00	5.0	25.0	5.2

Insert	Designation	Insert seat size	Turning		Grooving	Cermet			Coated				Uncoated		
			Feed (mm/rev)	ap (mm)	Feed (mm/rev)	PV3030	CT3000	TT6300	TT6080	TT5100	TT9080	TT7220	TT8020	K10	
	<b>TDIT 3.00E-1.50</b>	3	0.15-0.28	0.0-1.5	0.08-0.18									●	●
	<b>4.00E-2.00</b>	4	0.18-0.35	0.0-2.0	0.10-0.20									●	●
	<b>5.00E-2.50</b>	5	0.20-0.42	0.0-2.5	0.12-0.23									●	●
	<b>6.00E-3.00</b>	6	0.25-0.54	0.0-3.0	0.15-0.27									●	●



● Standard item











<b>MIN</b>	<b>T</b>	<b>R</b>	<b>04</b>	<b>040</b>	<b>005</b>	<b>D010</b>
1	7	2	3	4	5	6

## 1 TOPMICRO series

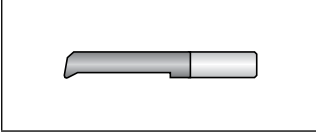

## 2 Hand of tool

R Right hand  
L Left hand

## 3 Shank dia.

04 4.0mm  
07 7.0mm

## 4 Max. depth

050 5.0mm  
140 14.0mm

## 5 Corner radius

010 0.10mm  
020 0.20mm

## 6 Min. bore dia.

D010 1.0mm

## 7 Application type

T	Turning and chamfering
B	Back turning
P	Turning and profiling
U	Undercutting and chamfering
C	Turning & 45° chamfering
G	Grooving and turning
A	Grooving along shaft
F	Face grooving
R	Full radius for internal boring and profiling
N	ISO full profile internal threading
SL	Sleeve for MINS



## Sleeves

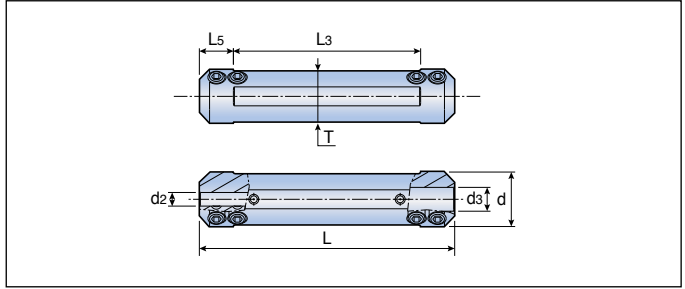

Designation	Dimension (mm)						
	d	d2	d3	L	L5	L3	T
<b>MINSL 12-4-4</b>	12.00	4.00	4.00	75.00	10.00	55.00	10.30
<b>14-4-4</b>	14.00	4.00	4.00	75.00	10.00	55.00	12.00
<b>16-4-7</b>	16.00	4.00	7.00	75.00	10.00	55.00	15.00
<b>20-4-7</b>	20.00	4.00	7.00	90.00	10.00	70.00	18.00
<b>22-4-7</b>	22.00	4.00	7.00	90.00	10.00	70.00	20.00
<b>25-4-7</b>	25.00	4.00	7.00	100.00	10.00	80.00	23.00

## Spare parts

Designation	Set screw	Wrench		
<b>MINSL 12</b>	SS M5x0.8x4-MG	L-W 2.5		
<b>MINSL 14/16/20/22/25</b>	SS M5x0.8x6-MG	L-W 2.5		







## Mini carbide bars for internal turning and chamfering

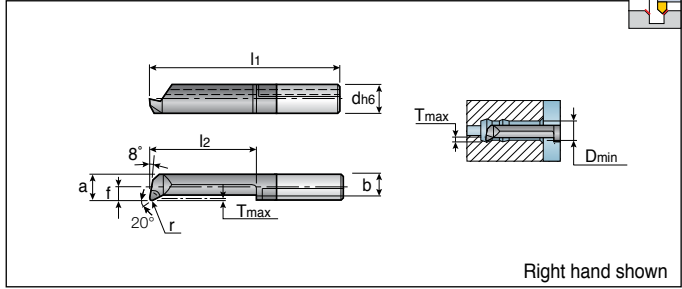

Designation	Dimension (mm)									R/L	Grade TT9030
	d	f	a	b	l <sub>1</sub>	l <sub>2</sub>	r±0.05	T <sub>max</sub>	D <sub>min</sub>		
<b>MINTR07-090015D050</b>	7.00	0.90	4.40	3.65	25.00	10.00	0.15	0.50	5.00	R	●
<b>140015D050</b>	7.00	0.90	4.40	3.65	30.00	15.00	0.15	0.50	5.00	R	●
<b>190015D050</b>	7.00	0.90	4.40	3.65	35.00	20.00	0.15	0.50	5.00	R	●
<b>240015D050</b>	7.00	0.90	4.40	3.65	40.00	25.00	0.15	0.50	5.00	R	●
<b>290015D050</b>	7.00	0.90	4.40	3.65	45.00	30.00	0.15	0.50	5.00	R	●
<b>340015D050</b>	7.00	0.90	4.40	3.65	50.00	35.00	0.15	0.50	5.00	R	●
<b>140015D060</b>	7.00	1.80	5.30	4.40	30.00	15.00	0.15	0.50	6.00	R	●
<b>210015D060</b>	7.00	1.80	5.30	4.40	37.00	22.00	0.15	0.50	6.00	R	●
<b>240015D060</b>	7.00	1.80	5.30	4.40	40.00	25.00	0.15	0.50	6.00	R	●
<b>290015D060</b>	7.00	1.80	5.30	4.40	45.00	30.00	0.15	0.50	6.00	R	●
<b>340015D060</b>	7.00	1.80	5.30	4.40	50.00	35.00	0.15	0.50	6.00	R	●
<b>410015D060</b>	7.00	1.80	5.30	4.40	57.00	42.00	0.15	0.50	6.00	R	●
<b>190015D068</b>	7.00	2.80	6.30	5.40	35.00	20.00	0.15	0.60	6.80	R	●
<b>240015D068</b>	7.00	2.80	6.30	5.40	40.00	25.00	0.15	0.60	6.80	R	●
<b>290015D068</b>	7.00	2.80	6.30	5.40	45.00	30.00	0.15	0.60	6.80	R	●
<b>340015D070</b>	7.00	2.80	6.30	5.40	50.00	35.00	0.15	0.60	7.00	R	●
<b>390015D070</b>	7.00	2.80	6.30	5.40	55.00	40.00	0.15	0.60	7.00	R	●
<b>440015D070</b>	7.00	2.80	6.30	5.40	60.00	45.00	0.15	0.60	7.00	R	●
<b>490015D070</b>	7.00	2.80	6.30	5.40	65.00	50.00	0.15	0.60	7.00	R	●
<b>MINTL07-090015D050</b>	7.00	0.90	4.40	3.65	25.00	10.00	0.15	0.50	5.00	L	●
<b>140015D050</b>	7.00	0.90	4.40	3.65	30.00	15.00	0.15	0.50	5.00	L	●
<b>190015D050</b>	7.00	0.90	4.40	3.65	35.00	20.00	0.15	0.50	5.00	L	●
<b>240015D050</b>	7.00	0.90	4.40	3.65	40.00	25.00	0.15	0.50	5.00	L	●
<b>290015D050</b>	7.00	0.90	4.40	3.65	45.00	30.00	0.15	0.50	5.00	L	●
<b>140015D060</b>	7.00	1.80	5.30	4.40	30.00	15.00	0.15	0.50	6.00	L	●
<b>210015D060</b>	7.00	1.80	5.30	4.40	37.00	22.00	0.15	0.50	6.00	L	●
<b>240015D060</b>	7.00	1.80	5.30	4.40	40.00	25.00	0.15	0.50	6.00	L	●
<b>290015D060</b>	7.00	1.80	5.30	4.40	45.00	30.00	0.15	0.50	6.00	L	●
<b>190015D068</b>	7.00	2.80	6.30	5.40	35.00	20.00	0.15	0.60	6.80	L	●
<b>290015D068</b>	7.00	2.80	6.30	5.40	45.00	30.00	0.15	0.60	6.80	L	●
<b>340015D070</b>	7.00	2.80	6.30	5.40	50.00	35.00	0.15	0.60	7.00	L	●

●: Standard item

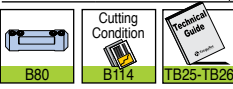

# MINP R 04/07

TOPMICRO

Mini carbide bars for internal turning and profiling

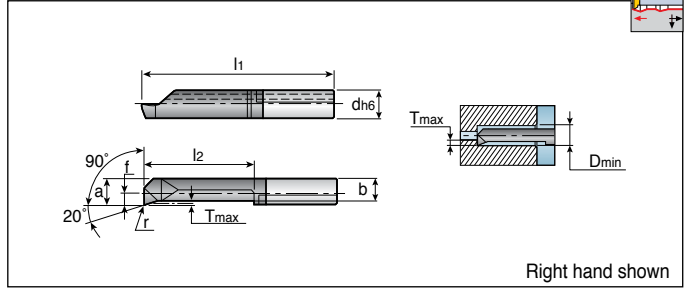

Designation	Dimension (mm)									R/L	Grade TT9030
	d	f	a	b	l <sub>1</sub>	l <sub>2</sub>	r ±0.05	T <sub>max</sub>	D <sub>min</sub>		
<b>MINPR04- 090010D028</b>	4.00	0.60	2.60	2.20	25.50	10.50	0.10	0.20	2.80	R	●
<b>150010D028</b>	4.00	0.60	2.60	2.20	31.50	16.50	0.10	0.20	2.80	R	●
<b>090010D040</b>	4.00	1.50	3.50	2.90	25.50	10.50	0.10	0.30	4.00	R	●
<b>150010D040</b>	4.00	1.50	3.50	2.90	31.50	16.50	0.10	0.30	4.00	R	●
<b>MINPR07- 140015D050</b>	7.00	0.90	4.40	3.65	30.00	15.00	0.15	0.50	5.00	R	●
<b>190015D050</b>	7.00	0.90	4.40	3.65	35.00	20.00	0.15	0.50	5.00	R	●

● Standard item



# MINC R 07

TOPMICRO

Mini carbide bars for internal turning and 45° chamfering

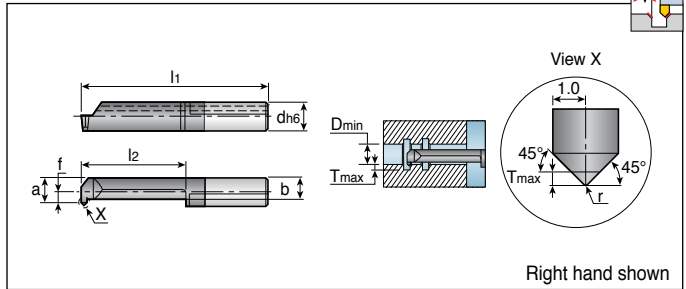

Designation	Dimension (mm)									R/L	Grade TT9030
	d	f	a	b	l <sub>1</sub>	l <sub>2</sub>	r ±0.04	T <sub>max</sub>	D <sub>min</sub>		
<b>MINCR07-140020D050</b>	7.00	0.90	4.40	3.20	30.00	15.00	0.20	0.70	5.00	R	●
<b>190020D050</b>	7.00	0.90	4.40	3.20	35.00	20.00	0.20	0.70	5.00	R	●
<b>190020D068</b>	7.00	2.80	6.30	3.80	35.00	20.00	0.20	0.70	6.80	R	●

● Standard item





# MING R/L 07

TOPMICRO

Mini carbide bars for grooving and turning

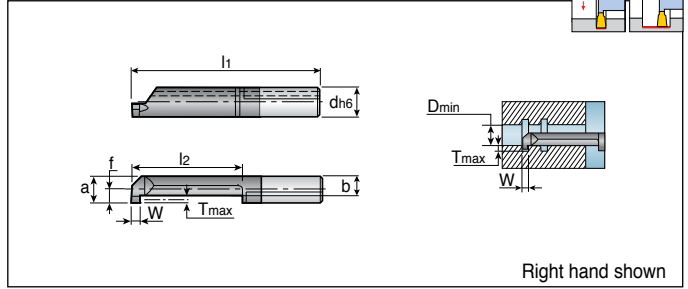

Designation	Dimension (mm)									R/L	Grade TT9030
	d	W±0.05	f	a	b	l1	l2	Tmax	Dmin		
<b>MINGR07-090100D050</b>	7.00	1.00	0.90	4.40	3.00	25.00	10.00	1.00	5.00	R	●
<b>140100D050</b>	7.00	1.00	0.90	4.40	3.00	30.00	15.00	1.00	5.00	R	●
<b>090150D050</b>	7.00	1.50	0.90	4.40	3.00	25.00	10.00	1.00	5.00	R	●
<b>140150D050</b>	7.00	1.50	0.90	4.40	3.00	30.00	15.00	1.00	5.00	R	●
<b>090200D050</b>	7.00	2.00	0.90	4.40	3.00	25.00	10.00	1.00	5.00	R	●
<b>190200D050</b>	7.00	2.00	0.90	4.40	3.00	35.00	20.00	1.00	5.00	R	●
<b>090100D060</b>	7.00	1.00	1.80	5.30	3.10	25.00	10.00	1.80	6.00	R	●
<b>140100D060</b>	7.00	1.00	1.80	5.30	3.10	30.00	15.00	1.80	6.00	R	●
<b>210100D060</b>	7.00	1.00	1.80	5.30	3.10	37.00	22.00	1.80	6.00	R	●
<b>290100D060</b>	7.00	1.00	1.80	5.30	3.10	45.00	30.00	1.80	6.00	R	●
<b>090150D060</b>	7.00	1.50	1.80	5.30	3.10	25.00	10.00	1.80	6.00	R	●
<b>140150D060</b>	7.00	1.50	1.80	5.30	3.10	30.00	15.00	1.80	6.00	R	●
<b>210150D060</b>	7.00	1.50	1.80	5.30	3.10	37.00	22.00	1.80	6.00	R	●
<b>240150D060</b>	7.00	1.50	1.80	5.30	3.10	40.00	25.00	1.80	6.00	R	●
<b>290150D060</b>	7.00	1.50	1.80	5.30	3.10	45.00	30.00	1.80	6.00	R	●
<b>090200D060</b>	7.00	2.00	1.80	5.30	3.10	25.00	10.00	1.80	6.00	R	●
<b>140200D060</b>	7.00	2.00	1.80	5.30	3.10	30.00	15.00	1.80	6.00	R	●
<b>210200D060</b>	7.00	2.00	1.80	5.30	3.10	37.00	22.00	1.80	6.00	R	●
<b>240200D060</b>	7.00	2.00	1.80	5.30	3.10	40.00	25.00	1.80	6.00	R	●
<b>290200D060</b>	7.00	2.00	1.80	5.30	3.10	45.00	30.00	1.80	6.00	R	●
<b>090100D068</b>	7.00	1.00	2.70	6.20	3.30	25.00	10.00	2.50	6.80	R	●
<b>140100D068</b>	7.00	1.00	2.70	6.20	3.30	30.00	15.00	2.50	6.80	R	●
<b>210100D068</b>	7.00	1.00	2.70	6.20	3.30	37.00	22.00	2.50	6.80	R	●
<b>090150D068</b>	7.00	1.50	2.70	6.20	3.30	25.00	10.00	2.50	6.80	R	●
<b>140150D068</b>	7.00	1.50	2.70	6.20	3.30	30.00	15.00	2.50	6.80	R	●
<b>210150D068</b>	7.00	1.50	2.70	6.20	3.30	37.00	22.00	2.50	6.80	R	●
<b>290150D068</b>	7.00	1.50	2.70	6.20	3.30	45.00	30.00	2.50	6.80	R	●
<b>090200D068</b>	7.00	2.00	2.70	6.20	3.30	25.00	10.00	2.50	6.80	R	●
<b>140200D068</b>	7.00	2.00	2.70	6.20	3.30	30.00	15.00	2.50	6.80	R	●
<b>210200D068</b>	7.00	2.00	2.70	6.20	3.30	37.00	22.00	2.50	6.80	R	●
<b>290200D068</b>	7.00	2.00	2.70	6.20	3.30	45.00	29.00	2.50	6.80	R	●
<b>MINGL07-090100D060</b>	7.00	1.00	1.80	5.30	3.10	25.00	10.00	1.80	6.00	L	●
<b>090150D060</b>	7.00	1.50	1.80	5.30	3.10	25.00	10.00	1.80	6.00	L	●
<b>140200D068</b>	7.00	2.00	2.70	6.20	3.30	30.00	15.00	2.50	6.80	L	●

● Standard item



Contents





# MINA R 07

TOPMICRO

Mini carbide bars for grooving along shaft

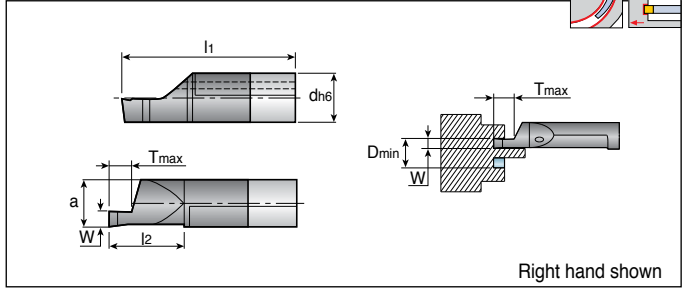

Designation	Dimension (mm)							R/L	Grade
	d	W	a	l <sub>1</sub>	l <sub>2</sub>	T <sub>max</sub>	D <sub>min</sub>		TT9030
<b>MINAR07 -200200D060</b>	7.00	2.00	5.20	36.00	21.00	4.00	6.00	R	●



● Standard item

# MINR R 07

TOPMICRO

Mini carbide bars, full radius for internal boring and profiling

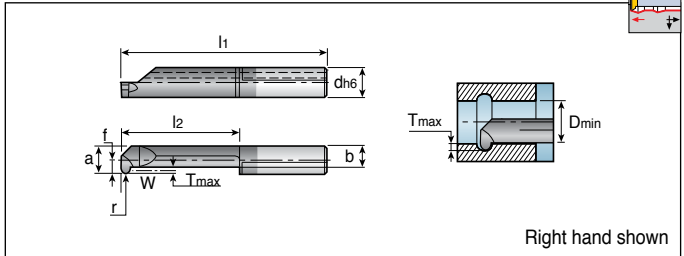

Designation	Dimension (mm)										R/L	Grade
	d	W±0.05	f	a	b	r	l <sub>1</sub>	l <sub>2</sub>	T <sub>max</sub>	D <sub>min</sub>		TT9030
<b>MINRR07- 190050D050</b>	7.00	1.00	0.90	4.40	3.10	0.50	35.00	20.00	1.00	5.00	R	●
<b>240050D060</b>	7.00	1.00	1.80	5.30	3.20	0.50	40.00	25.00	1.80	6.00	R	●
<b>290050D068</b>	7.00	1.00	2.80	6.30	3.55	0.50	45.00	30.00	2.50	6.80	R	●



● Standard item









## 1 TaeguTec TOPCUT series

### 2 Application type

<b>E</b>	External turning
<b>R</b>	Reverse turning
<b>B</b>	Back turning
<b>T</b>	Threading
<b>P</b>	Parting

### 3 Hand of tool

<b>R</b>	Right hand
<b>L</b>	Left hand

### 4 Insert thickness

<b>4</b>	3.97mm
----------	--------

### 5 Width of insert

<b>07</b>	0.7mm
<b>10</b>	1.0mm
<b>12</b>	1.2mm
<b>15</b>	1.5mm
<b>18</b>	1.8mm
<b>20</b>	2.0mm

### 6 Corner radius

<b>000</b>	0mm
<b>003</b>	0.03mm
<b>005</b>	0.05mm
<b>010</b>	0.10mm
<b>015</b>	0.15mm

### 7 Tmax (TVPR/L only)

<b>45</b>	4.5mm
<b>50</b>	5.0mm
<b>60</b>	6.0mm

## General turning

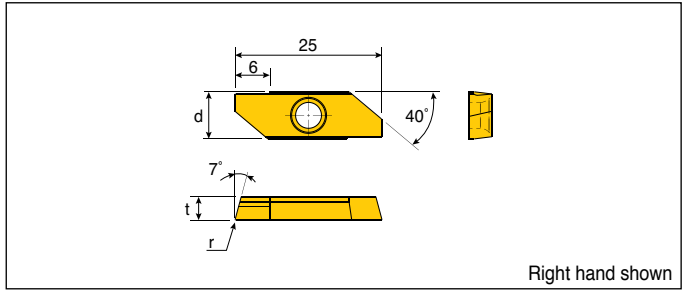
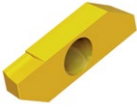

Designation	Feed (mm/rev)	ap (mm)	Dimension (mm)				Grade (TT9010)	
			d	t	r	T <sub>max</sub>	R	L
<b>TVER/L 40003</b>	0.01-0.15	0.1-5.5	8	3.97	0.03	5.5	●	
	<b>40010</b>	0.01-0.15	8	3.97	0.10	5.5	●	

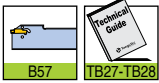

●: Standard item

# TVRR/L

## Reverse turning

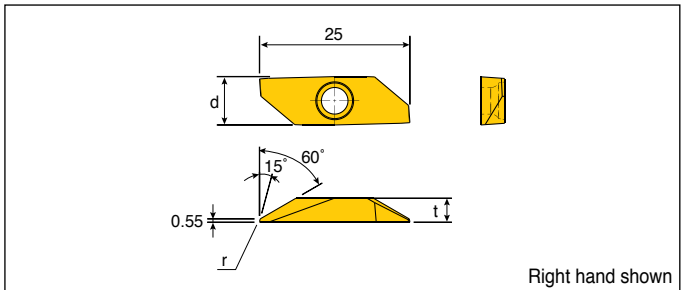
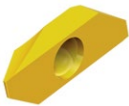

Designation	Feed (mm/rev)	ap (mm)	Dimension (mm)				Grade (TT9010)	
			d	t	r	T <sub>max</sub>	R	L
<b>TVRR/L 40003-60</b>	0.01-0.15	0.1-5.5	8	3.97	0.03	5.5	●	
	<b>40010-60</b>	0.01-0.15	8	3.97	0.10	5.5	●	

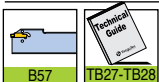

●: Standard item

## Back turning

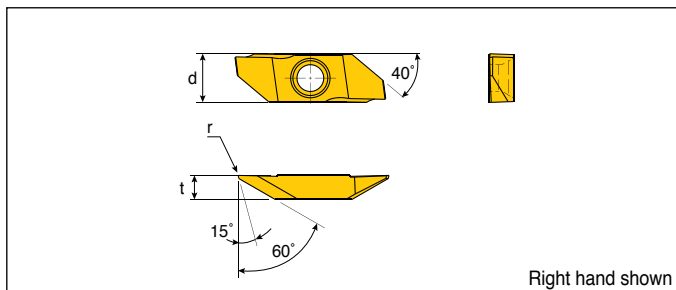
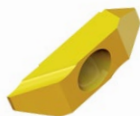

Designation	Feed (mm/rev)	ap (mm)	Dimension (mm)				Grade (TT9010)	
			d	t	r	T <sub>max</sub>	R	L
<b>TVBR/L 40003</b>	0.01-0.15	0.1-5.5	8	3.97	0.03	5.5	●	●
<b>40005</b>	0.01-0.15	0.1-5.5	8	3.97	0.05	5.5	●	●
<b>40010</b>	0.01-0.15	0.1-5.5	8	3.97	0.10	5.5	●	●
<b>40015</b>	0.01-0.15	0.1-5.5	8	3.97	0.15	5.5	●	●
<b>40005-H<sup>(1)</sup></b>	0.01-0.15	0.1-5.5	8	3.97	0.05	5.5	●	●
<b>40010-H<sup>(1)</sup></b>	0.01-0.15	0.1-5.5	8	3.97	0.10	5.5	●	●
<b>40015-H<sup>(1)</sup></b>	0.01-0.15	0.1-5.5	8	3.97	0.15	5.5	●	●

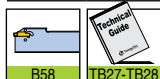

● <sup>(1)</sup> With honed edges

● Standard item

# TVTR/L

## Threading

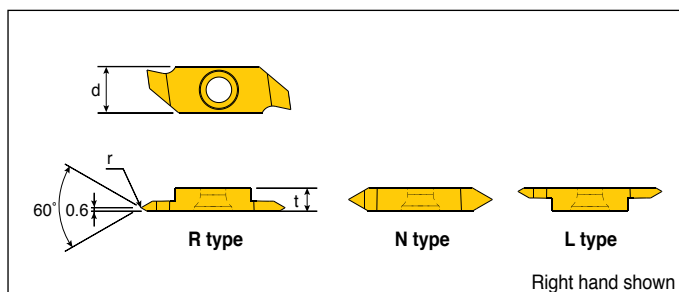
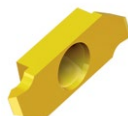

Designation	Dimension (mm)			Grade (TT9010)	
	d	t	r	R	L
<b>TVTR/L 41203-R</b>	8	3.97	0.03	●	
<b>40003-N</b>	8	3.97	0.03	●	
<b>41203-L</b>	8	3.97	0.03		

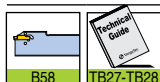

● TVTR 41203-R/L → pitch range: 0.5 - 1.0mm  
 ● TVTR 40003-N → pitch range: 0.5 - 2.0mm

● Standard item



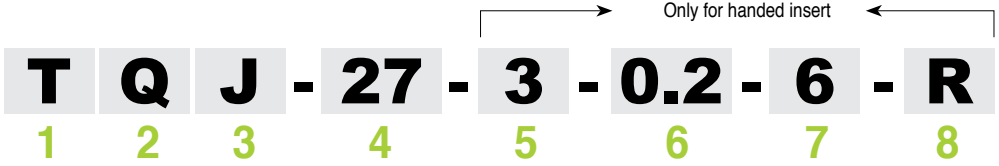



## 1 TaeguTec

## 2 QUADRUSH

## 3 Chip breaker type

		
<b>C</b>	<b>J</b>	<b>S</b>
For medium	For light	For light & tailor made

## 4 Circular circumference of the insert

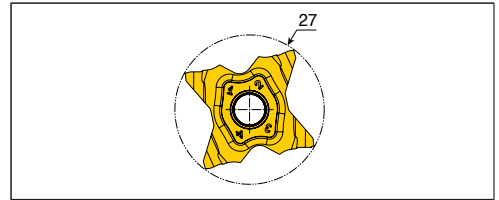

## 5 Width of insert

	<p>1.00 = 1.0 mm</p> <p>1.50 = 1.5mm</p> <p>2.53 = 2.53mm</p> <p>3.18 = 3.18mm</p>
--	--

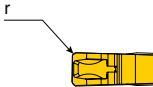

## 6 Corner radius

	<p>0.10 = 0.1mm</p> <p>0.20 = 0.2mm</p> <p>0.30 = 0.3mm</p> <p>0.40 = 0.4mm</p>
--	---

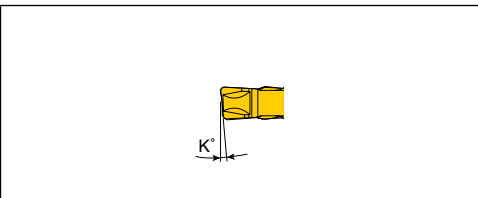
## 7 Lead angle



## 8 Hand of insert

	
<b>L</b>	<b>R</b>
Left hand	Right hand

## Precision grooving, parting and recessing insert

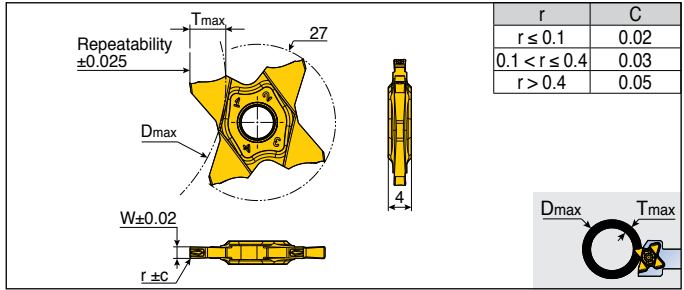

r	C
$r \leq 0.1$	0.02
$0.1 < r \leq 0.4$	0.03
$r > 0.4$	0.05

Designation	Feed (mm/rev)	W±0.02	r	T <sub>max</sub>	D <sub>max</sub>											Grade		
					T <sub>≤3.0</sub>	T <sub>≤3.5</sub>	T <sub>≤4.0</sub>	T <sub>≤4.5</sub>	T <sub>≤5.0</sub>	T <sub>≤5.5</sub>	T <sub>≤5.7</sub>	T <sub>≤6.0</sub>	T <sub>≤6.2</sub>	T <sub>≤6.4</sub>				
<b>TQJ 27-0.50-0.00</b>	0.02-0.04	0.50	0.00	1.0	-	-	-	-	-	-	-	-	-	-	-	-	-	TT9080
<b>27-0.50-0.04</b>	0.02-0.04	0.50	0.04	2.5	-	-	-	-	-	-	-	-	-	-	-	-	●	
<b>27-0.75-0.10</b>	0.02-0.05	0.75	0.10	2.5	-	-	-	-	-	-	-	-	-	-	-	-	●	
<b>27-0.80-0.00</b>	0.02-0.05	0.80	0.00	1.6	-	-	-	-	-	-	-	-	-	-	-	-		
<b>27-1.00-0.06</b>	0.03-0.07	1.00	0.06	3.5	N.L.	600	-	-	-	-	-	-	-	-	-	-		
<b>27-1.00-0.10</b>	0.03-0.07	1.00	0.10	3.5	N.L.	600	-	-	-	-	-	-	-	-	-	-	●	
<b>27-1.04-0.00</b>	0.03-0.07	1.04	0.00	2.0	-	-	-	-	-	-	-	-	-	-	-	-		
<b>27-1.20-0.00</b>	0.03-0.07	1.20	0.00	2.0	-	-	-	-	-	-	-	-	-	-	-	-		
<b>27-1.25-0.10</b>	0.03-0.07	1.25	0.10	3.5	N.L.	600	-	-	-	-	-	-	-	-	-	-	●	
<b>27-1.25-0.20</b>	0.03-0.07	1.25	0.20	3.5	N.L.	600	-	-	-	-	-	-	-	-	-	-	●	
<b>27-1.40-0.00</b>	0.03-0.08	1.40	0.00	2.0	-	-	-	-	-	-	-	-	-	-	-	-		
<b>27-1.47-0.00</b>	0.03-0.08	1.47	0.00	2.5	-	-	-	-	-	-	-	-	-	-	-	-		
<b>27-1.50-0.10</b>	0.03-0.08	1.50	0.10	5.7	N.L.	600	280	180	130	50	35	-	-	-	-	-	●	
<b>27-1.50-0.20</b>	0.03-0.08	1.50	0.20	5.7	N.L.	600	280	180	130	50	35	-	-	-	-	-	●	
<b>27-1.57-0.10</b>	0.03-0.08	1.57	0.10	3.0	N.L.	-	-	-	-	-	-	-	-	-	-	-		
<b>27-1.57-0.15</b>	0.03-0.08	1.57	0.15	3.0	N.L.	-	-	-	-	-	-	-	-	-	-	-		
<b>27-1.70-0.10</b>	0.03-0.08	1.70	0.10	3.0	N.L.	-	-	-	-	-	-	-	-	-	-	-		
<b>27-1.75-0.10</b>	0.03-0.08	1.75	0.10	3.0	N.L.	-	-	-	-	-	-	-	-	-	-	-	●	
<b>27-1.75-0.20</b>	0.03-0.08	1.75	0.20	3.0	N.L.	-	-	-	-	-	-	-	-	-	-	-	●	
<b>27-1.78-0.18</b>	0.04-0.10	1.78	0.18	3.0	N.L.	-	-	-	-	-	-	-	-	-	-	-		
<b>27-1.85-0.20</b>	0.04-0.10	1.85	0.20	3.0	N.L.	-	-	-	-	-	-	-	-	-	-	-	●	
<b>27-1.96-0.15</b>	0.04-0.10	1.96	0.15	3.0	N.L.	-	-	-	-	-	-	-	-	-	-	-		
<b>27-2.00-0.10</b>	0.04-0.10	2.00	0.10	6.4	N.L.	600	280	180	130	105	85	60	50	30	-	-	●	
<b>27-2.00-0.20</b>	0.04-0.10	2.00	0.20	6.4	N.L.	600	280	180	130	105	85	60	50	30	-	-	●	
<b>27-2.22-0.15</b>	0.04-0.10	2.22	0.15	3.5	N.L.	600	-	-	-	-	-	-	-	-	-	-		
<b>27-2.30-0.20</b>	0.04-0.10	2.30	0.20	3.5	N.L.	600	-	-	-	-	-	-	-	-	-	-		
<b>27-2.39-0.15</b>	0.04-0.10	2.39	0.15	5.7	N.L.	600	280	180	130	50	35	-	-	-	-	-		
<b>27-2.47-0.20</b>	0.04-0.10	2.47	0.20	5.7	N.L.	600	280	180	130	50	35	-	-	-	-	-		
<b>27-2.50-0.10</b>	0.04-0.10	2.50	0.10	5.7	N.L.	600	280	180	130	50	35	-	-	-	-	-	●	
<b>27-2.50-0.30</b>	0.05-0.12	2.50	0.30	5.7	N.L.	600	280	180	130	50	35	-	-	-	-	-	●	
<b>27-2.70-0.10</b>	0.05-0.12	2.70	0.10	6.2	N.L.	600	280	180	135	105	95	85	78	-	-	-		
<b>27-2.87-0.20</b>	0.05-0.12	2.87	0.20	6.2	N.L.	600	280	180	135	105	95	85	78	-	-	-		



● N.L. = No limit

● Standard item



# TQJ 27

QUAD-RUSH

## Precision grooving, parting and recessing insert

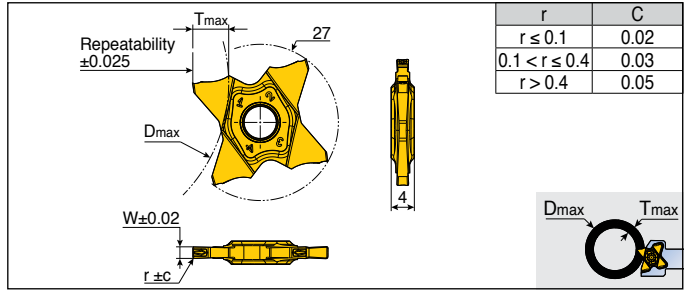

r	C
$r \leq 0.1$	0.02
$0.1 < r \leq 0.4$	0.03
$r > 0.4$	0.05

Designation	Feed (mm/rev)	W±0.02	r	Tmax	Dmax										Grade
					T ≤ 3.0	T ≤ 3.5	T ≤ 4.0	T ≤ 4.5	T ≤ 5.0	T ≤ 5.5	T ≤ 5.7	T ≤ 6.0	T ≤ 6.2	T ≤ 6.4	
<b>TQJ 27-3.00-0.00</b>	0.05-0.12	3.00	0.00	6.4	N.L.	600	280	180	135	105	95	85	78	55	
<b>27-3.00-0.20</b>	0.05-0.12	3.00	0.20	6.4	N.L.	600	280	180	135	105	95	85	78	55	
<b>27-3.00-0.30</b>	0.05-0.12	3.00	0.30	6.4	N.L.	600	280	180	135	105	95	85	78	55	●
<b>27-3.00-0.40</b>	0.05-0.12	3.00	0.40	6.4	N.L.	600	280	180	135	105	95	85	78	55	
<b>27-3.15-0.15</b>	0.05-0.12	3.15	0.15	6.4	N.L.	600	280	180	135	105	95	85	78	68	
<b>27-3.18-0.20</b>	0.05-0.12	3.18	0.20	6.4	N.L.	600	280	180	135	105	95	85	78	68	●

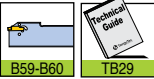

● N.L. = No limit

● Standard item

# TQJ 27

QUAD-RUSH

## Parting insert

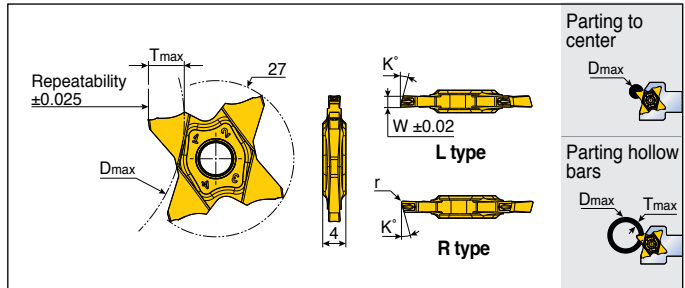

Designation	Feed (mm/rev)	W±0.02	r	K°	Parting to center		Parting hollow bars		Grade
					Dmax	Tmax	Dmax	Tmax	
<b>TQJ 27-1.00-15R/L</b>	0.02-0.06	1.00	0.06	15	7.0	3.5	600		●
<b>27-1.50-6R/L</b>	0.02-0.06	1.50	0.06	6	12.0	5.7	35		●
<b>27-1.50-15R/L</b>	0.02-0.06	1.50	0.06	15	12.0	5.7	35		●
<b>27-2.00-6R/L</b>	0.03-0.08	2.00	0.10	6	13.0	6.4	30		●
<b>27-2.00-15R/L</b>	0.03-0.08	2.00	0.10	15	13.0	6.4	30		●

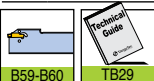

● Standard item







# TQC 27

QUAD-RUSH

## Parting insert

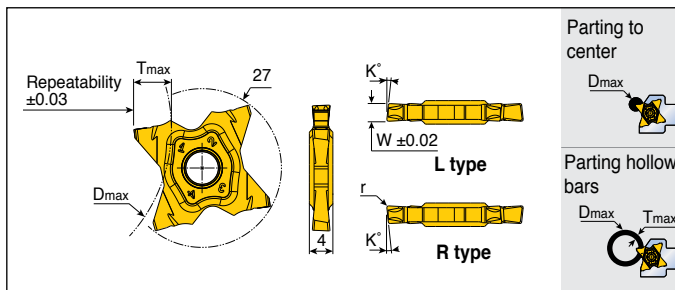

Designation	Feed (mm/rev)	W±0.02	r	K°	Parting to center		Parting hollow bars		Grade
					Dmax	Tmax	Dmax	Tmax	
<b>TQC 27-1.50-6R/L</b>	0.03-0.07	1.50	0.06	6	12.0	5.7	35	●	
<b>27-1.50-15R/L</b>	0.03-0.07	1.50	0.06	15	12.0	5.7	35	●	
<b>27-2.00-6R/L</b>	0.04-0.14	2.00	0.10	6	13.0	6.4	30	●	
<b>27-2.00-15R/L</b>	0.04-0.14	2.00	0.10	15	13.0	6.4	30	●	

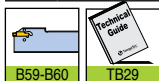

● Standard item

# TQC 27

QUAD-RUSH

## Full radius

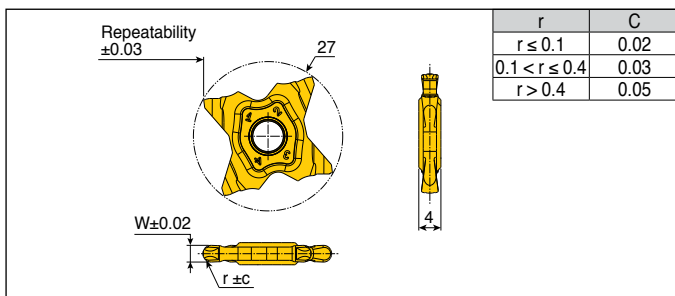

Designation	Feed (mm/rev)	W±0.02	r	Tmax	Dmax										Grade	
					T ≤ 3.0	T ≤ 3.5	T ≤ 4.0	T ≤ 4.5	T ≤ 5.0	T ≤ 5.5	T ≤ 5.7	T ≤ 6.0	T ≤ 6.2	T ≤ 6.4		
<b>TQC 27-1.57-0.79</b>	0.05-0.09	1.57	0.79	3.0	N.L.	-	-	-	-	-	-	-	-	-	-	●
<b>27-2.00-1.00</b>	0.05-0.13	2.00	1.00	3.5	N.L.	600	-	-	-	-	-	-	-	-	-	●
<b>27-2.39-1.20</b>	0.06-0.17	2.39	1.20	5.7	N.L.	600	280	180	130	50	35	-	-	-	-	●
<b>27-3.00-1.50</b>	0.06-0.20	3.00	1.50	6.4	N.L.	600	280	180	135	105	95	85	78	55	-	●

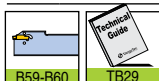

● N.L. = No limit

● Standard item



**TDIT**    **3.20** - **0.00** - **0.25** -    - **TT8020**

1                    2                    3                    4                    5                    6

## 1 Main style of insert

T type: Chip breaker  
G type: Non-chip breaker

## 2 Insert width

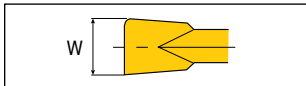

## 3 Corner radius

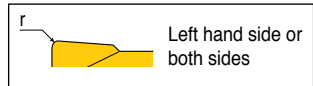

## 4 Corner radius

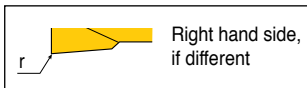

## 5 Additional codes

## 6 Grades

Parting & Grooving	Turning & Grooving
<p>TDJ / TDC</p> <p>TSJ / TSC</p>	<p>TDT      TDA      TDG</p> <p>TDIT      TDFT Internal      Face</p>

### Special profile inserts

Tailor-made inserts are available upon request.

Shape	Designation	Remarks
	TDT 4.00-0.50	Symmetrical type
	TDIT 3.20-0.00-0.25	Non-symmetrical type
	TDT 3.30-1.65	Full-R type
	TDT 4.00-0.30-5RA	L: Chamfer on left hand side R: Chamfer on right hand side
	TDT 3.10-0.10-15LA	
	TDG 5.28-1.20-R25A	
	TDT 5.28-1.20-L25A	



Shape	Designation	Remarks
	TDG 4.40-1.82-29A	L: Chamfer on left hand side R: Chamfer on right hand side
	TDT 4.40-1.50-30A	
	TDT 5.28-2.05-45R25L	
	TDG 4.40-0.15-60A	
	TDG 5.40-0.10-30R50L	
	TDT 3.90-4.00	
	TDT 1.90-T3.5C	
	TDT 1.90-0.30-4.20T	

Shape	Designation	Remarks
	<p>TDG 1.98-T4.5C</p>	
	<p>TDFT 3.80E-0.25</p>	
	<p>TDIT 2.60-1.30</p>	
<p>The others</p>	<p>Available upon customer's request</p>	

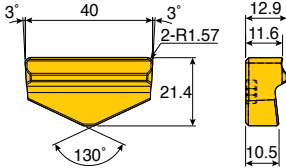
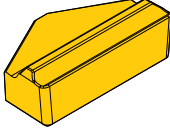
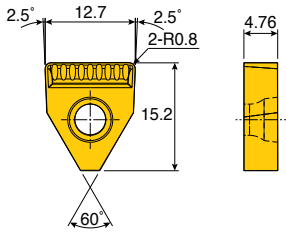
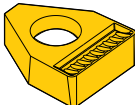
Designation	Dimension (mm)	Remarks
XNMR 401416-HD		
XNGT 332-GV		

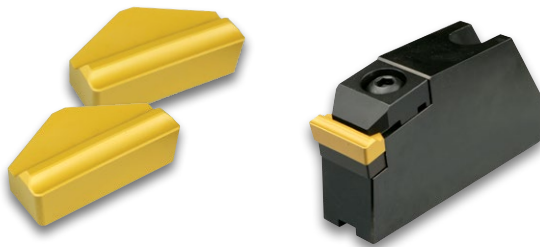

Shape	Designation	Grade	Pitch	Z
	B ZT 2706035-N4	Carbide	3.56	4
	B ZT 2706043-N3	Carbide	3.56	3
	B ZT 22-5.76-0.425-N3	Carbide	3.56	3
	B ZT 13.5-5.76-N3	Carbide	3.56	3

Shape	Designation	Grade	Pitch	Z
	B ZT 22-5.76-N3-A20	Carbide	3.56	3
	B ZT1215-NO	Carbide	2.34	5
	B ZT 5030-ITX	Ceramic	3.56	6
	B ZT 22-5.76-N3-CE-P	Ceramic	3.56	3
	D INMN 09A111	Ceramic	3.56	3

# Recommended Cutting Conditions

## Turning and grooving

ISO	Material	Condition	Tensile strength (N/mm <sup>2</sup> )	Hardness HB	Material No.	Groove-turn, profiling, undercutting cutting speed Vc(m/min)	
						KP300	TB650
P	Non-alloy steel, cast steel, free cutting steel	0.1-0.25 %C	Annealed	420	125	1	
		0.25-0.25 %C	Annealed	650	190	2	
		0.25-0.25 %C	Quenched and tempered	850	250	3	
		0.55-0.80 %C	Annealed	750	220	4	
		0.55-0.80 %C	Quenched and tempered	1000	300	5	
	Low alloy steel and cast steel (Less than 5% of alloying elements)		Annealed	600	200	6	
				930	275	7	
			Quenched and tempered	1000	300	8	
				1200	350	9	
	High alloy steel, cast steel and tool steel		Annealed	680	200	10	
			Quenched and tempered	1100	325	11	
M	Stainless steel and cast steel	Ferritic / martensitic	680	200	12		
		Martensitic	820	240	13		
		Austenitic	600	180	14		
K	Gray cast iron (GG)	Ferritic		160	15		
		Pearlitic		250	16		
	Cast iron nodular (GGG)	Ferritic		180	17		
		Pearlitic		260	18		
	Malleable cast iron	Ferritic		130	19		
Pearlitic			230	20			
N	Aluminum - Wrought alloy	Not cureable		60	21	150-2500	
		Cured		100	22	150-2500	
	Aluminum-cast, alloyed	<=12% Si	Not cureable		75	23	150-2500
			Cured		90	24	150-2500
		>12% Si	High temp.		130	25	330-800
	Copper alloys	>1% Pb	Free cutting		110	26	
			Brass		90	27	330-800
		Electrolitic copper		100	28	190-400	
	Non-metallic		Duroplastics, fiber plastics			29	
			Hard rubber			30	
S	High temp. alloys	Fe based	Annealed		200	31	
			Cured		280	32	
		Ni or Co based	Annealed		250	33	
			Cured		350	34	
			Cast		320	35	
	Titanium, Ti alloys			Rm 400		36	
			Alpha+beta alloys cured	Rm 1050		37	
H	Hardened steel	Hardened		55HRC	38	90-110	
		Hardened		60HRC	39	80-100	
	Chilled cast iron	Cast		400	40	180-200	
	Cast iron nodular	Hardened		55HRC	41	90-110	

• For more information of material groups, see the Technical Guide "material conversion table".

■ Steel   
 ■ Stainless steel   
 ■ Cast iron   
 ■ Nonferrous   
 ■ High temp. alloys   
 ■ Hardened steel

# Recommended Cutting Conditions

## Turning and grooving

Groove-turn, profiling, undercutting cutting speed Vc(m/min)						Internal grooving, face grooving cutting speed Vc(m/min)				
CT3000	TT6300	TT6080	TT9080 TT7220	TT8020	K10	TT6300	T6080	TT9080 TT7220	TT8020	K10
100-210			100-200	100-180				100-150	80-110	
100-200			100-180	100-150				60-100	60-90	
80-180			80-160	80-130						
80-180			80-160	80-130				60-110	50-90	
70-150			70-130	70-120						
100-180			100-160	10-150				60-110	40-70	
90-180			80-160	80-150				70-110	40-60	
80-170			80-150	80-130						
80-150			80-130	80-120				60-90	30-50	
90-130			90-130	90-110				60-90	30-50	
50-80			50-80	50-70				50-80	30-40	
80-170			80-170	80-170				50-130	40-80	
80-150			80-150	80-150						
80-170			80-170	80-170				40-130	30-80	
	150-270	110-250			70-100	90-140	70-120			40-60
	120-170	90-140			50-90	80-120	60-100			40-60
	150-250	120-230			70-100	90-130	70-110			40-60
	120-200	90-180			60-90	80-110	60-90			30-50
	120-200	90-180			60-120	80-130	60-110			20-40
	100-180	80-150			50-80	60-100	50-90			20-40
					300-800					100-300
					230-310					100-300
					280-830					100-300
					200-510					100-300
					130-300					80-200
					120-200					80-150
					90-150					60-100
			30-50	20-30	30-40			20-40	20-30	
			20-40	15-20	20-40			15-30	15-20	
			20-30	15-20	20-30			15-20	15-20	
			15-20	15-20	15-20			15-20	15-20	
			15-20	15-20	15-20			15-20	15-20	
			130-170	80-100	100-130			90-120	60-80	
			40-70	15-30	20-50			20-50	15-30	
	30-50				20-40	15-25				15-20
	30-50				20-30	15-25				15-20
	30-50				20-50	15-25				15-25
	30-50				20-40	15-25				15-25

# Recommended Cutting Conditions

## Parting and grooving

ISO	Material	Condition	Tensile strength (N/mm <sup>2</sup> )	Hardness HB	Material No.	Cutting speed Vc(m/min)			
						TT9080 TT7200	TT8020	K10	
P	Non-alloy steel, cast steel, free cutting steel	0.1-0.25 %C	Annealed	420	125	1	140-250	80-120	
		0.25-0.25 %C	Annealed	650	190	2	130-220	80-110	
		0.25-0.25 %C	Quenched and tempered	850	250	3	90-200	70-90	
		0.55-0.80 %C	Annealed	750	220	4	100-220	70-100	
		0.55-0.80 %C	Quenched and tempered	1000	300	5	70-170	40-70	
	Low alloy steel and cast steel (Less than 5% of alloying elements)	Quenched and tempered	600	200	6	90-120	70-100		
			930	275	7	80-170	50-70		
			1000	300	8	70-130	40-60		
			1200	350	9	50-120	30-50		
	High alloy steel, cast steel and tool steel	Annealed	680	200	10	60-140	50-80		
Quenched and tempered		1100	325	11	50-70	30-60			
M	Stainless steel and cast steel	Ferritic / martensitic	680	200	12	70-170	80-120		
		Martensitic	820	240	13	60-150	60-90		
		Austenitic	600	180	14	90-180	60-90		
K	Gray cast iron (GG)	Ferritic		160	15	100-230		60-80	
		Pearlitic		250	16	90-180		50-70	
	Cast iron nodular (GGG)	Ferritic		180	17	190-300		70-100	
		Pearlitic		260	18	120-220		70-90	
	Malleable cast iron	Ferritic		130	19	120-250		60-85	
Pearlitic			230	20	100-210		45-75		
N	Aluminum - Wrought alloy	Not cureable		60	21				
		Cured		100	22				
	Aluminum-cast, alloyed	Not cureable	<=12% Si		75	23			
			Cured		90	24			
			>12% Si	High temp.		130	25		
	Copper alloys	Free cutting	>1% Pb		110	26			
			Brass		90	27			
			Electrolitic copper		100	28			
	Non-metallic	Duroplastics, fiber plastics			29				
		Hard rubber			30				
S	High temp. alloys	Fe based	Annealed		200	31	40-70		35-50
			Cured		280	32	30-50		25-40
		Ni or Co based	Annealed		250	33	30-40		20-30
			Cured		350	34	15-25		15-20
			Cast		320	35	15-30		15-20
	Titanium, Ti alloys		Rm 400		36	90-190		150-200	
		Alpha+beta alloys cured	Rm 1050		37	30-60		50-80	
H	Hardened steel	Hardened		55HRC	38				
		Hardened		60HRC	39				
	Chilled cast iron	Cast		400	40				
	Cast iron nodular	Hardened		55HRC	41				

• For more information of material groups, see the Technical Guide "material conversion table".

■ Steel 
 ■ Stainless steel 
 ■ Cast iron 
 ■ Nonferrous 
 ■ High temp. alloys 
 ■ Hardened steel



# Recommended Cutting Conditions

QUAD-RUSH

QUADRUSH

ISO	Material	Condition	Tensile strength (N/mm <sup>2</sup> )	Hardness HB	Material No.	Cutting speed Vc(m/min)	
						TT9080	
P	Non-alloy steel, cast steel, free cutting steel	0.1-0.25 %C	Annealed	420	125	1	140-250
		0.25-0.25 %C	Annealed	650	190	2	130-220
		0.25-0.25 %C	Quenched and tempered	850	250	3	90-200
		0.55-0.80 %C	Annealed	750	220	4	100-220
		0.55-0.80 %C	Quenched and tempered	1000	300	5	70-170
	Low alloy steel and cast steel (Less than 5% of alloying elements)	Annealed	600	200	6	90-120	
			930	275	7	80-170	
		Quenched and tempered	1000	300	8	70-130	
			1200	350	9	50-120	
	High alloy steel, cast steel and tool steel	Annealed	680	200	10	60-140	
Quenched and tempered		1100	325	11	50-70		
M	Stainless steel and cast steel	Ferritic / martensitic	680	200	12	70-170	
		Martensitic	820	240	13	60-150	
		Austenitic	600	180	14	90-180	
K	Gray cast iron (GG)	Ferritic		160	15	100-230	
		Pearlitic		250	16	90-180	
	Cast iron nodular (GGG)	Ferritic		180	17	190-300	
		Pearlitic		260	18	120-220	
	Malleable cast iron	Ferritic		130	19	120-250	
Pearlitic			230	20	100-210		
N	Aluminum - Wrought alloy	Not cureable		60	21		
		Cured		100	22		
	Aluminum-cast, alloyed	<=12% Si	Not cureable		75	23	
			Cured		90	24	
		>12% Si	High temp.		130	25	
	>1% Pb	Free cutting		110	26		
	Copper alloys	Brass		90	27		
		Electrolitic copper		100	28		
	Non-metallic	Duroplastics, fiber plastics			29		
Hard rubber				30			
S	High temp. alloys	Fe based	Annealed		200	31	40-70
			Cured		280	32	30-50
		Ni or Co based	Annealed		250	33	30-40
			Cured		350	34	15-25
	Cast			320	35	15-30	
Titanium, Ti alloys		Rm 400		36	90-190		
	Alpha+beta alloys cured	Rm 1050		37	30-60		
H	Hardened steel	Hardened		55HRC	38		
		Hardened		60HRC	39		
	Chilled cast iron	Cast		400	40		
	Cast iron nodular	Hardened		55HRC	41		

• For more information of material groups, see the Technical Guide "material conversion table".

■ Steel   
 ■ Stainless steel   
 ■ Cast iron   
 ■ Nonferrous   
 ■ High temp. alloys   
 ■ Hardened steel

• **Feed rate:** Neutral: 0.05-0.18 mm/rev, Handed: Reduce 20% feed rate

Contents

# Recommended Cutting Conditions

## Ceramic T-CLAMP ULTRA PLUS insert

Material		Grooving	Turning
P	High hardened steel	Vc (m/min)	Not recommended
		F (mm/rev)	
K	Cast iron	Vc (m/min)	600-800
		F (mm/rev)	0.1-0.2
			250-350
			0.08-0.20
		600-800	600-800
		0.1-0.2	0.1-0.24

• Above condition is adapted to TDT 4E-0.4T CE AB30

## TOPMICRO

Cutting speed Vc(m/min)	Feed (mm/rev)		
	Turning / Back turning	Grooving	Face grooving
P 30-150	0.01-0.08	0.01-0.05	0.01-0.04
M 30-130			
K 30-150			
N 50-200			
S 10-50			