

MN^NL

September 2016
www.taegutec.com



Marketing News Letter No. 2016-14

STARMILL

Specification Changes to the Current SED Line



KEY POINT

The Total length (L) and depth of cut (ap) of some STARMILL SED type solid carbide end mills have been changed.

Trends in the metalworking market continue to shift towards difficult-to-cut materials which are characterized by sticky like properties during machining. Thus, the market demand for more suitable cutting tools has also increased.

As such, the **STARMILL SED** end mill product line has undergone modifications to meet this continuing demand as well as the need for customer convenience.

Modifications:

SED 4...U/U-C/U-R

Total length (L) and depth of cut (ap)

For further questions, please contact the relevant product manager.

Availability

Available when the current stock is depleted

Price

Available in the GAL system

Sincerely,
TaeguTec



Cho Yeo-myeong
Rotating Product Manager

Sincerely,
TaeguTec



Lee Jae-wook
Milling Product Manager

SED 4...U

4 flute medium flat



- Excellent chatter damping credit to unequal spacing of cutting edges

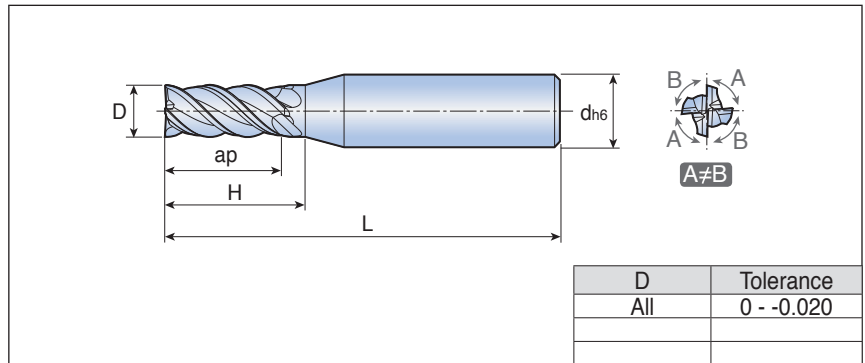
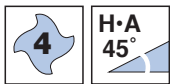

Designation	Feed (mm/tooth)	Dimension (mm)					Grade TT5515	Current	Modification
		D	L	ap	H	d			
SED 4040U	0.020-0.040	4	57	12	14	6	●	●	
4050U	0.020-0.040	5	57	13 → 15	16	6	●		●
4060U	0.025-0.070	6	57	13 → 15	-	6	●		●
4080U	0.030-0.090	8	63 → 70	19 → 25	-	8	●		●
4100U	0.030-0.100	10	72	22 → 25	-	10	●		●
4120U	0.035-0.110	12	83	26 → 30	-	12	●		●
4160U	0.050-0.130	16	92 → 100	32 → 42	-	16	●		●
4200U	0.050-0.170	20	104	38 → 48	-	20	●		●

●: Standard item

SED 4...U-C

4 flute medium corner chamfer

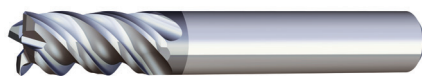

- Excellent chatter damping credit to unequal spacing of cutting edges

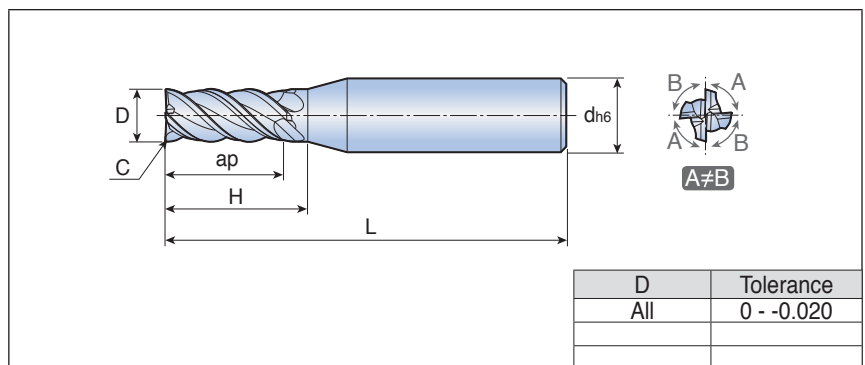
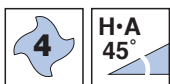

Designation	Feed (mm/tooth)	Dimension (mm)						Grade TT5515	Current	Modification
		D	C	L	ap	H	d			
SED 4040U-C0.1	0.020-0.040	4	0.1	57	12	14	6	●	●	
4060U-C0.2	0.025-0.070	6	0.2	57	13 → 15	-	6	●		●
4080U-C0.3	0.030-0.090	8	0.3	63 → 70	19 → 25	-	8	●		●
4100U-C0.3	0.030-0.100	10	0.3	72	22 → 25	-	10	●		●
4120U-C0.4	0.035-0.110	12	0.4	83	26 → 30	-	12	●		●

●: Standard item

SED 4...U-R

4 flute medium corner radius



- Excellent chatter damping credit to unequal spacing of cutting edges

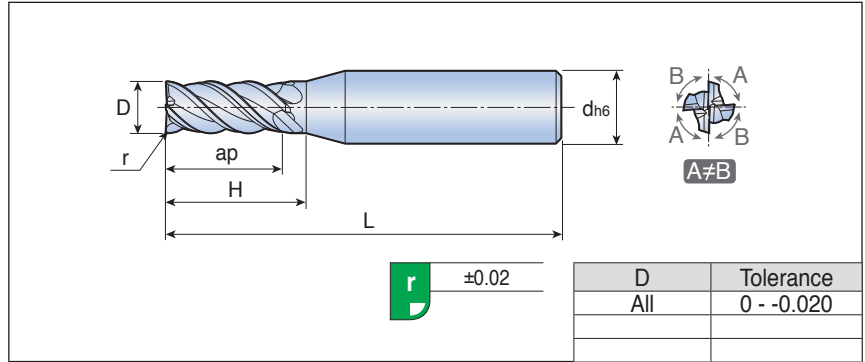

Designation	Feed (mm/tooth)	Dimension (mm)						Grade TT5515	Current	Modification
		D	r	L	ap	H	d			
SED 4040U-R0.1	0.020-0.040	4	0.1	57	12	14	6	●	●	
4050U-R0.15	0.020-0.040	5	0.15	57	13 → 15	16	6	●		●
4060U-R0.2	0.025-0.070	6	0.2	57	13 → 15	-	6	●		●
4080U-R0.2	0.030-0.090	8	0.2	63 → 70	19 → 25	-	8	●		●
4100U-R0.2	0.030-0.100	10	0.2	72	22 → 25	-	10	●		●
4120U-R0.3	0.035-0.110	12	0.3	83	26 → 30	-	12	●		●

●: Standard item