

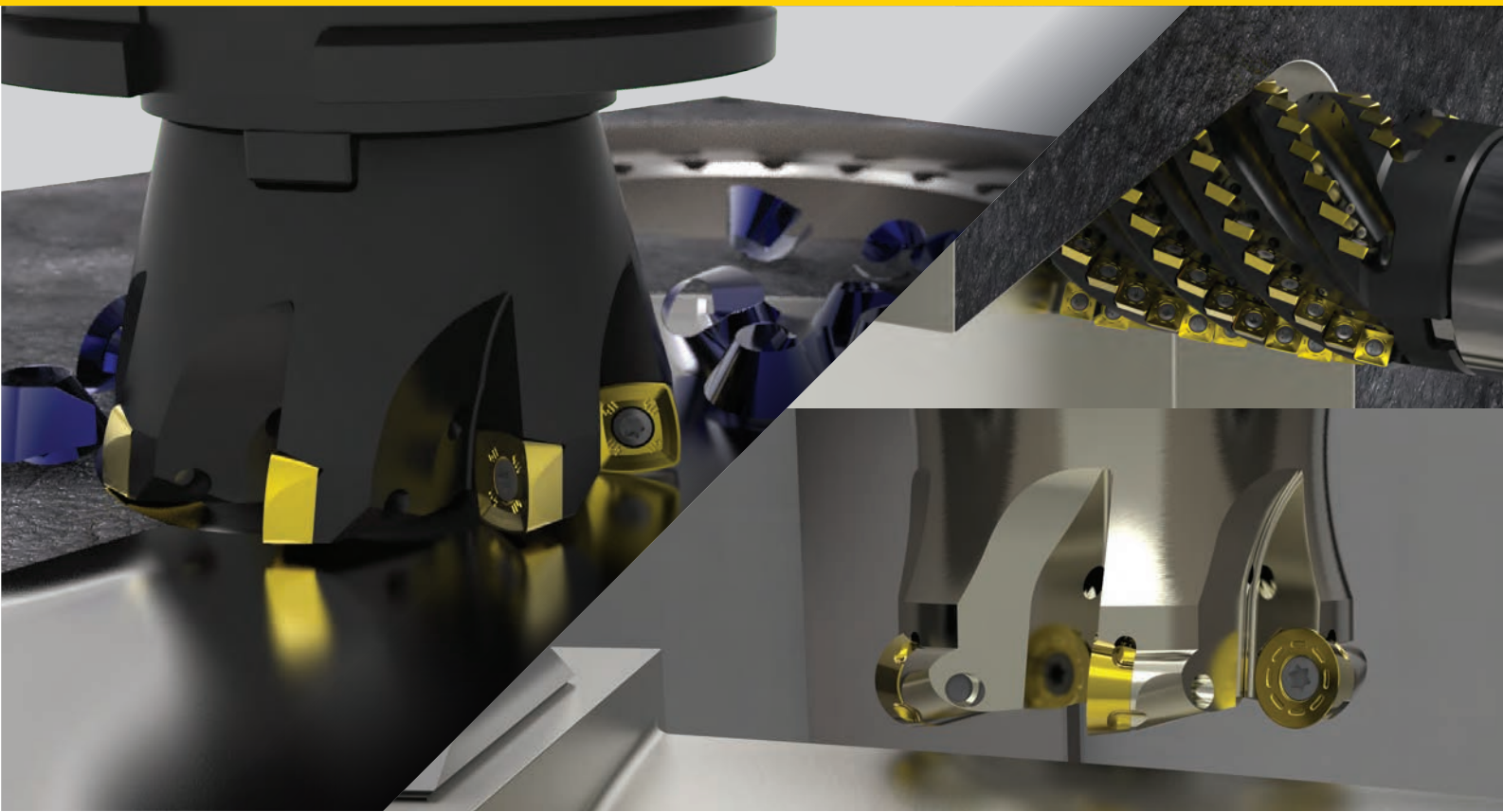

# CUTTING TOOLS

Stellram® Cutting Tools



**HIGH PERFORMANCE MILLING SOLUTIONS**





**Patented Breakthroughs for Difficult to Machine Materials:  
Cut Faster. Cut Longer. Cut More Profitably.**

These Kennametal Milling Systems are specifically designed and manufactured for machining high performance, difficult-to-machine materials.

This capability was developed after years of advanced R&D in materials science and machining Titanium and Titanium Alloys, Nickel Alloys and Superalloys, Stainless Steel and Specialty Alloys, and Hard Materials.

The result: These proven “Best in Class” machining solutions presented in this brochure.

Our strategy is to bring “game changing” cutting tool solutions that deliver industry leading metal removal rates. Higher metal removal rates mean you increase capacity, make more profit and deliver in shorter lead times.

Stellram® high performance cutting tools are known for cutting titanium like butter and have found wide application in the aerospace, defense, power generation, oil and gas, medical, transportation and construction and mining industries.

	<b>Page</b>
Application Guide.....	2
Patented X-Grade Insert Technology.....	2
7792 Patented High Feed Milling.....	3 - 8
The <b>77</b> Family.....	9 - 14
5230 Chevron Long Edge Milling.....	15 - 18
5505 Ball Nose Contour Mills.....	19 - 22
5720 Profile Pocket Milling: Aluminium.....	23 - 26
5702 High Speed Aluminium Cutters.....	27 - 29



## Application Guide

Chamfer	Contour	Copy / 3D	Face
Full Ø Plunge	Helical Interpolation	Helical Interpolation with Bore Hole	Plunge
Pocket	Ramp	Shoulder/Profile	Shoulder/Profile/Slot
Slot/Shoulder	Spiral/Circular	T-Slot	Trochoidal

## Patented X-Grade Insert Technology

### 3-TIMES THE METAL REMOVAL RATE

Titanium and Nickel Based Alloys are some of the toughest machining jobs on earth.

And it is a rare element, a member of the platinum family, called Ruthenium, that is one of the key ingredients used in our patented X-Grade™ Technology cutting tools.

We combine Ruthenium with Cobalt to form an exclusive binder that cements our engineered carbide formulas in the making of these inserts.

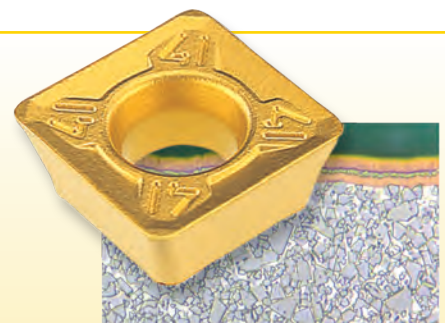

*X-Grade Inserts provide unmatched performance in cutting difficult to machine materials.*



## 7792 High Feed Milling

- Patented Cutter Designs
- Patented Insert Designs
- Patented Grades

**To remove the highest volume of metal  
in the shortest possible time**



## 7792: Increase Metal Removal Rate up to 90% or More!

### Modular

16mm – 32mm



- Cutting diameters from 16mm to 160mm
- Modular, Weldon, Cylindrical and Shell Mill cutter configurations
- Modular Tungsten Extensions maintain stability in deep pocket applications
- All inserts feature 4 cutting edges

### Weldon

25mm – 32mm



## The Patented 7792 Insert



The unique 7792 insert design provides outstanding operational security and performance, with enhanced metal removal capability.

### Cylindrical

16mm – 32mm



- Maximize tool life, versatility and performance
- Face, Pocket, Shoulder, Profile, Helical Interpolate, Ramp, Copy and Mill Turn with one tool
- 6 grades for materials from Aluminium to Superalloys
- 4 insert sizes available
- Depth of cut from 0,90mm to 3,50mm
- Coarse, medium and fine pitch cutters available for all machining conditions.

### Shell

40mm – 160mm





## How High Feed Cutters Work

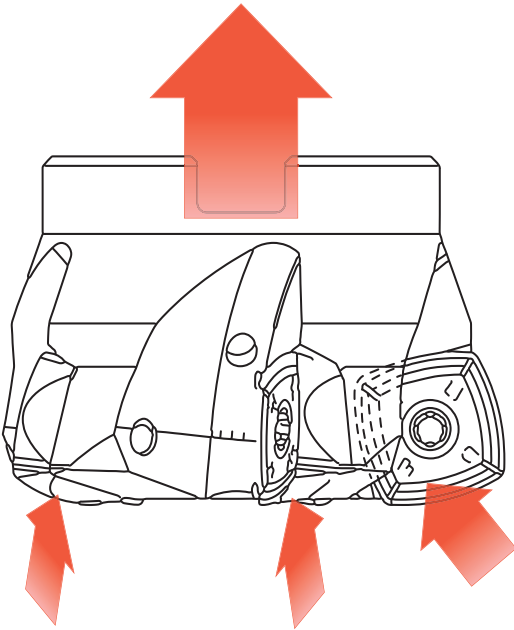

The patented design of High Feed Cutters and Inserts combine to drive the cutting forces axially into the spindle. This allows even less rigid machines to outperform newer machines with conventional cutters by taking high feed, shallow cuts.

- 5 times the feed rate of conventional face mills
- High feed, shallow cuts
- Dramatically reduced cycle times
- Reduced vibration
- Better quality parts in less than half the time
- Twice the tool life or more

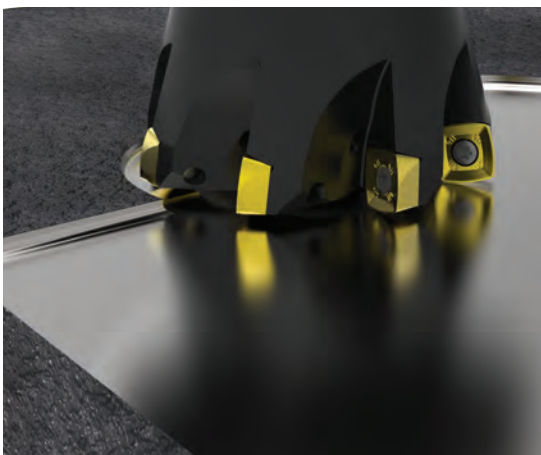

## Hard Case: The Ti Alpha Barrier

The Alpha Casing, which forms during the cooling of the Titanium billet and varies in thickness and hardness, creates nearly impossible machining conditions. The previous most cost effective solution was to chemically remove it with acid.

An aerospace customer was using our X-Grade inserts with our top performing button cutter on several titanium applications. This was our benchmark to test the 7792.

Here's how the 7792VXD12 with X-500 Grade inserts performed on a Ti 6-4 Alpha Case ...

- 24% less energy consumed
- 120% increase in material removal rate
- Nearly 3 times the tool life

The 7792 eliminated the need for highly toxic, dangerous chemicals and made effective Alpha Case machining a production reality.



## 7792 Case Histories



Material: 4140 steel – 280 - 320 HBN  
 Industry: Die/Mold  
 Job: 17 holes – 51,59mm diameter, 67,74mm deep  
 Cycle time: 4.5 hours

**7792 Solution:**  
 Cutter: Modular 7792VXD09 (25mm Cutter)  
 Extension: Anti-vibration, heavy-alloy Modular Shank  
 Insert Grade: X400  
 Process: High Feed Helical Interpolation  
 Cycle time: 1 minute 45 seconds per hole  
 Total Cycle time: 30 minutes

**90% Reduction in Cycle Time**



Material: 6-4 Titanium  
 Job: Machine pockets in aerospace component  
 Cycle time: 5.5 hours

**7792 Solution:**  
 Cutter: 7792VXD12 (160mm Cutter)  
 Insert Grade: X500  
 Cycle time: 1 hour 20 minutes

**75% Reduction in Cycle Time**



Material: 6-4 Titanium  
 Job: Turn a 1463mm diameter by 340mm deep ring  
 Industry: Aerospace  
 Turning Cycle time: 4 hours 35 minutes

**7792 Solution:**  
 Cutter: 7792VXE16 (125mm Cutter)  
 Insert Grade: X500  
 Process: Mill turning  
 Workpiece rotates on B axis at 0,26 RPM  
 Spiral milling feed rate of 60mm per revolution  
 Cycle time: 2 hours 24 minutes

**Spiral Milling Cuts Cycle Time 48%**





## High Feed Geometries

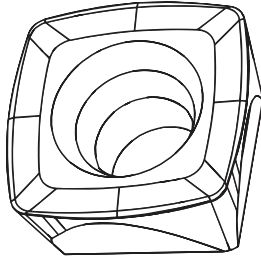

**-D**

Fully ground with flat top and variable hone.  
Hardened Materials up to 480HBN.

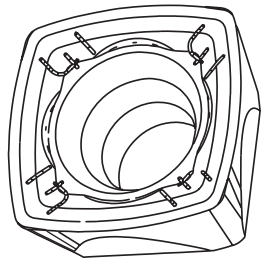

**-D41**

Positive geometry that reduces power consumption.

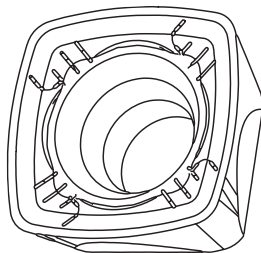

**-D411**

Positive geometry with larger corner radius (1,2mm) reduces cutting energy and provides better edge protection during lower radial engagement applications.

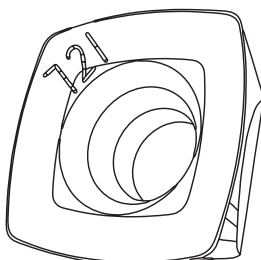

**-D721**

Positive, periphery ground, polished top rake face and sharp edge allows a freer cutting action and reduces built-up edge.

### Material Guide – Key to Recommended Inserts

#### Material Designation

Unalloyed Steels  
 Alloyed Steels  
 Stainless Steels  
 PH Stainless  
 Cast Irons  
 Aluminum & Alloys  
 High Temp. Alloys  
 Hard Materials



## High Feed Grades

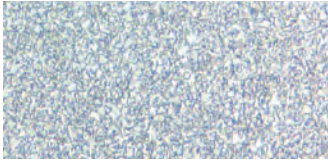

**GH2**

Uncoated Micrograin – Tough and able to handle high pressure, vibration and shock.

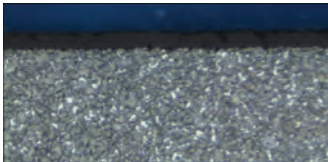

**X400**

Coating Type: PVD, TiAlN – Designed for high metal removal rates and interrupted cuts.

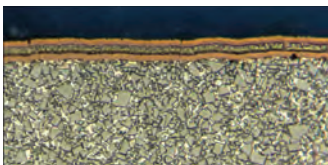

**X500**

Coating Type: CVD, TiN-TiC-TiN – High level of shock resistance; operates at low to medium cutting speeds; high metal removal rates.

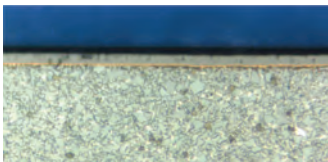

**SC3025**

Coating Type: CVD, TiN - TiCN - Al<sub>2</sub>O<sub>3</sub> – Multi-layer CVD coating offers wear and abrasion resistance.

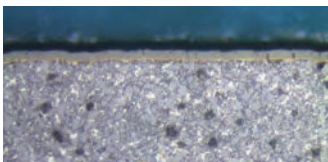

**SC6525**

Coating Type: CVD, TiN-TiCN-Al<sub>2</sub>O<sub>3</sub> – High Performance Machining at elevated surface speeds.

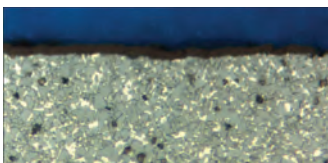

**SP6519**

Coating Type: PVD, TiAlN – Super nano coating is extremely hard for unmatched performance and virtually eliminates residual stress.

### Material Guide – Key to Recommended Inserts

#### Material Designation

Unalloyed Steels  
 Alloyed Steels  
 Stainless Steels  
 PH Stainless  
 Cast Irons  
 Aluminum & Alloys  
 High Temp. Alloys  
 Hard Materials

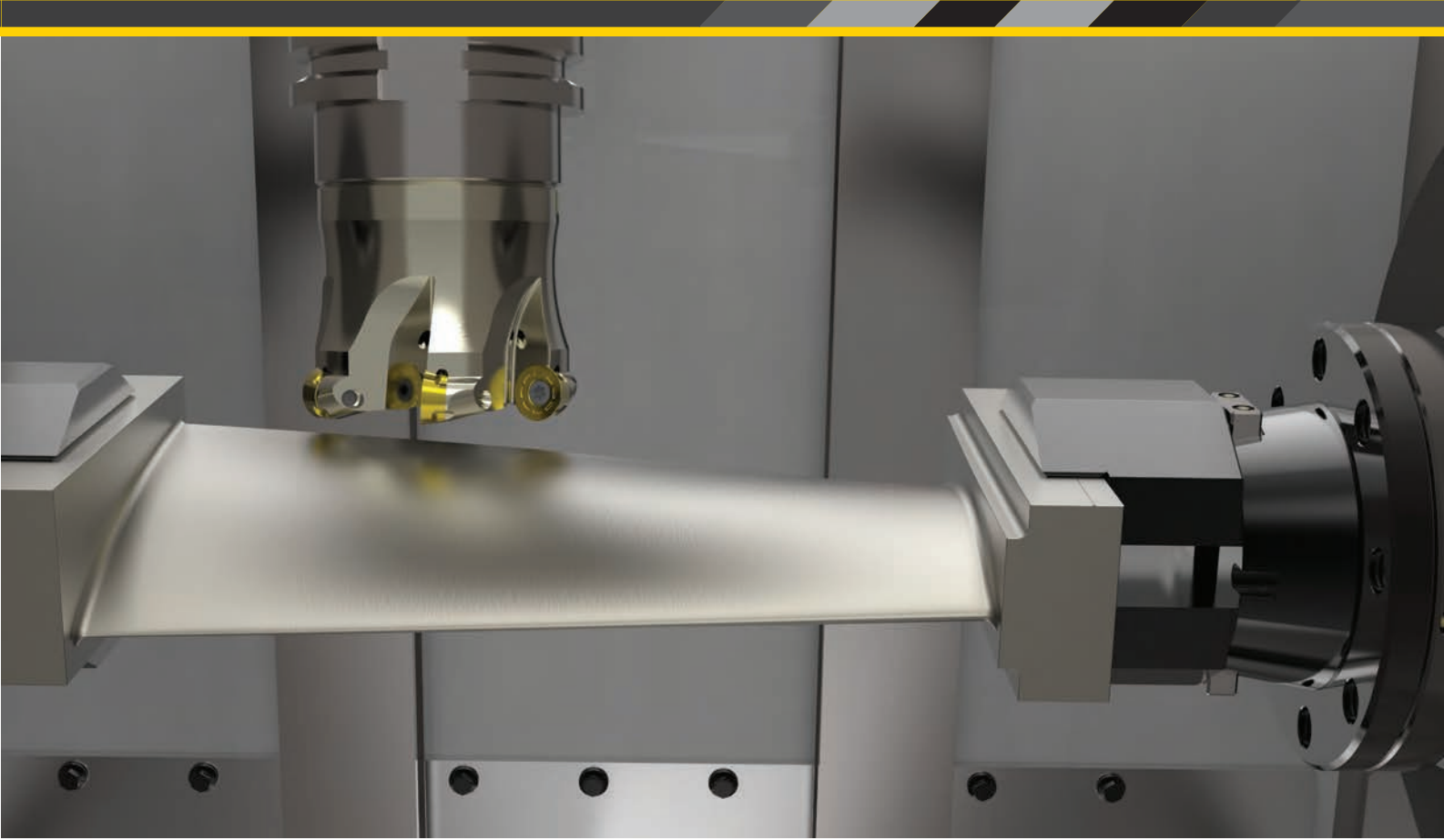

## The **77** Family

- Patented Cutter Designs
- Patented Insert Designs
- Patented Grades

**Excellent for roughing, semi-finishing  
and finishing of high-performance materials**



## The 77 Family

### Modular

16mm – 40mm



### Weldon

25mm



### Cylindrical

16mm – 32mm



### Shell

40mm – 160mm



## Three Families of Cutters are Featured:

- **7700VR08** small diameter standard button cutters (Cylindrical, Weldon and Modular: 16mm to 32mm)
- **7710VRD20** Anti-Rotation Shell Mill cutters (63mm to 160mm)
- **7713VR10 and 12** Patented Anti-Rotation Cutters (Cylindrical, Modular and Shell: 20mm to 80mm)

This collection of cutters shows the dynamics of Kennametal technology—taking the conventional to the highest level to machine the toughest high performance alloys.

## Continuous Cutting Under the Toughest Conditions

- Cutter diameters from 16mm to 160mm
- Maximum number of teeth for heavy feed operations
- Medium and close pitch cutters available
- Round button insert for maximum strength
- 8mm to 20mm insert diameters
- Low cutting forces
- Flute design maximizes chip evacuation
- Satin Silver coating extends cutter body life (only 7713VR series)
- Modular tools feature an Anti-Vibration Tungsten Extension with Through Coolant



## VRD / VR Anti-Rotation Technology

### *Maximum Chip Evacuation*

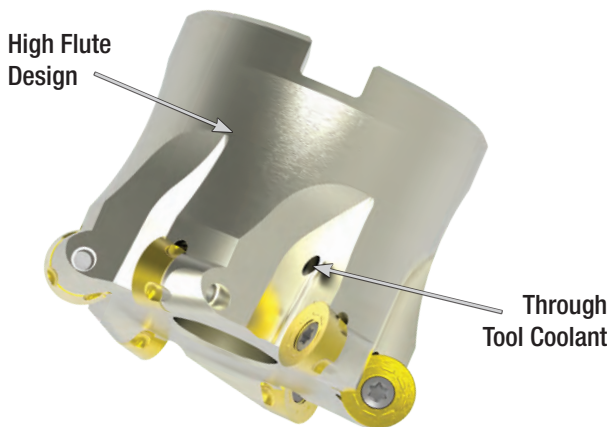

### *Maximum Tool Life*

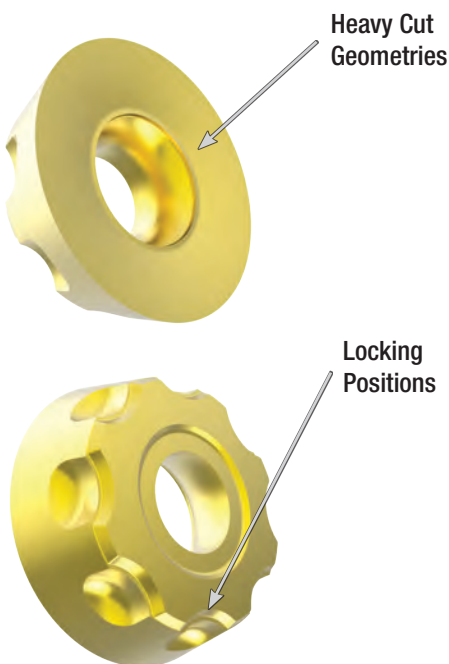

## The High Flute Indexing Cutter

The 7710 and 7713 series cutters feature a unique patented pocket system that locks the inserts into position to prevent inserts from moving during heavy machining.

- Through Coolant and unique flow through pocket design maximize chip evacuation and increase tool life

7713 Patented series cutter bodies are armored with Satin Silver plating to protect body integrity in milling high performance materials.

## The Positive Indexing Round Insert

The Anti-Rotation insert features four, five or eight locking positions which mate with the pocket of the cutter body.

- Positive positioning of the insert throughout the heaviest cuts
- Maximum indexes to optimize tool life and reduce tooling costs



## 77 Family Case Histories

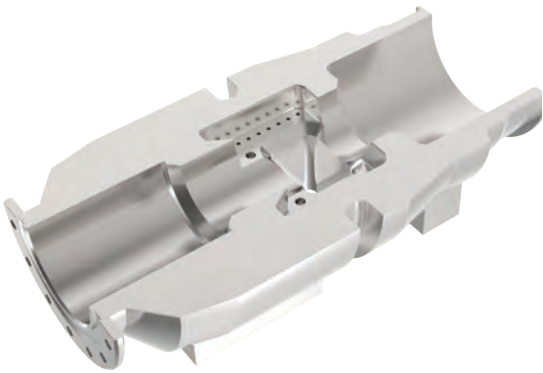

### 7710 Case History

Material: 600 Series High Temperature Alloy  
 Cutter: 7710VRD20 (100mm Cutter)  
 Component: Heat Exchanger Pump Housing  
 Industry: Power Generation - Nuclear  
 Insert Grade: X500  
 RPM: 105  
 Cutting Speed  $V_C$ : 33,5 m/min  
 Feed per Tooth  $f_z$ : 0,323mm  
 Feed Rate: 203 mm/min  
 Depth of Cut  $a_p$ : 6,35mm

#### **60% Reduction in Cycle Time**

- 150% Productivity Increase
- 60% Reduction in Tooling Costs
- Zero Failures
- Zero Defects
- Finishing Operation Eliminated



### 7713 Case History

Material: Stainless Steel 300 Series  
 Cutter: 7713VR12 (63mm Cutter)  
 Component: Turbine Blade  
 Industry: Power Generation  
 Insert Grade: SP6519  
 RPM: 909  
 Cutting Speed  $V_C$ : 180 m/min  
 Feed per Tooth  $f_z$ : 0,3mm  
 Feed Rate: 1,636 m/min  
 Depth of Cut  $a_p$ : 2,2mm

#### **80% Increase in Tool Life!**

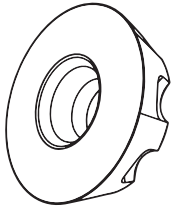

## 77 Family Geometries

**-25**

This geometry is specifically designed for heavy roughing applications and is the first choice for Steels and Cast Iron.

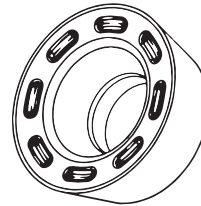
**-422**

This positive geometry features an 11° chip angle and an “E” edge preparation for roughing and semi finishing applications in difficult to machine materials.

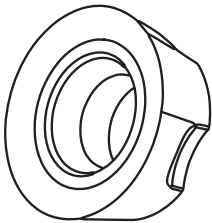
**-41**

This general purpose utility geometry has a positive cutting action and reinforced cutting edge for medium roughing and semi-finishing applications.

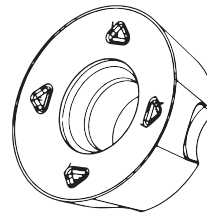
**-442**

This NEW positive roughing and semi-finishing geometry features an 11° chip angle and an “E” edge preparation to minimize the pressure from chip formation.

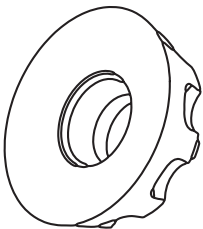
**-42**

This general purpose roughing and semi-finishing geometry features a positive rake and T-land to create a strong cutting edge designed to withstand high cutting forces and interrupted cuts.

**-701**

This precision ground extreme high positive geometry is especially suitable for finishing a wide range of materials at low feed rates and delivers excellent performance when machining thin-walled components.

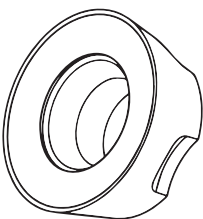
**-421**

This high positive geometry features high accuracy periphery grinding for precise control of the cutting edge. For semi-finishing and finishing applications.

Tool	-25	-41	-42	-421	-422	-442	-701
7700VR08		●			●		●
7710VRD20	●		●				
7713VR10		●		●	●		●
7713VR12		●		●		●	●

### Material Guide – Key to Recommended Inserts

#### Material Designation

Unalloyed Steels  
 Alloyed Steels  
 Stainless Steels  
 PH Stainless  
 Cast Irons  
 Aluminum & Alloys  
 High Temp. Alloys  
 Hard Materials



## 77 Family Grades

Tool	GH1	MP91M	SP4019	SP6519	X500	X700
7700VR08	●	●	●	●	●	
7710VRD20				●	●	
7713VR10	●	●	●	●	●	●
7713VR12	●	●		●	●	●

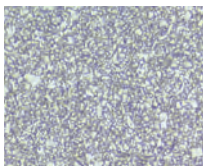

### GH1

*Uncoated, Micrograin*

This micrograin grade works well with or without coolant with low cutting pressure at high speeds due to sharp cutting edge.

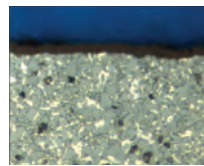

### SP6519

*Coating Type: PVD, TiAlN*

This grade features a combination of a tough substrate with a new generation of TiAlN super nano coating, making it virtually free of residual stress and extremely hard for unmatched performance.

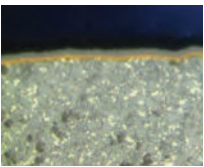

### MP91M

*Coating Type: CVD, TiN-MT-TiCN-Al2O3*

With its aluminium oxide coating, this grade is recommended every time wear characteristics are more important than toughness.

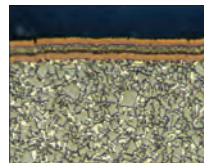

### X500

*Coating Type: CVD, TiN-TiC-TiN, X-Grade™ Technology*

High level of shock resistance; operates at low to medium cutting speeds; high metal removal rates while retaining a secure cutting edge.

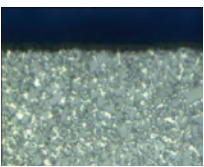

### SP4019

*Coating Type: PVD, TiAlN Micrograin*

This hard grade is designed for light roughing and finishing operations with lower chip sections.

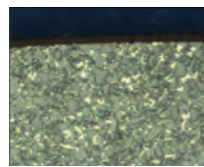

### X700

*Coating Type: PVD, TiAlN, X-Grade™ Technology*

This combination of a highly durable TiAlN PVD coating and specially developed carbide substrate delivers excellent tool life during long contact times of the cutting edge.

## Material Guide – Key to Recommended Inserts

### Material Designation

Unalloyed Steels 
 Alloyed Steels 
 Stainless Steels 
 PH Stainless 
 Cast Irons 
 Aluminum & Alloys 
 High Temp. Alloys 
 Hard Materials



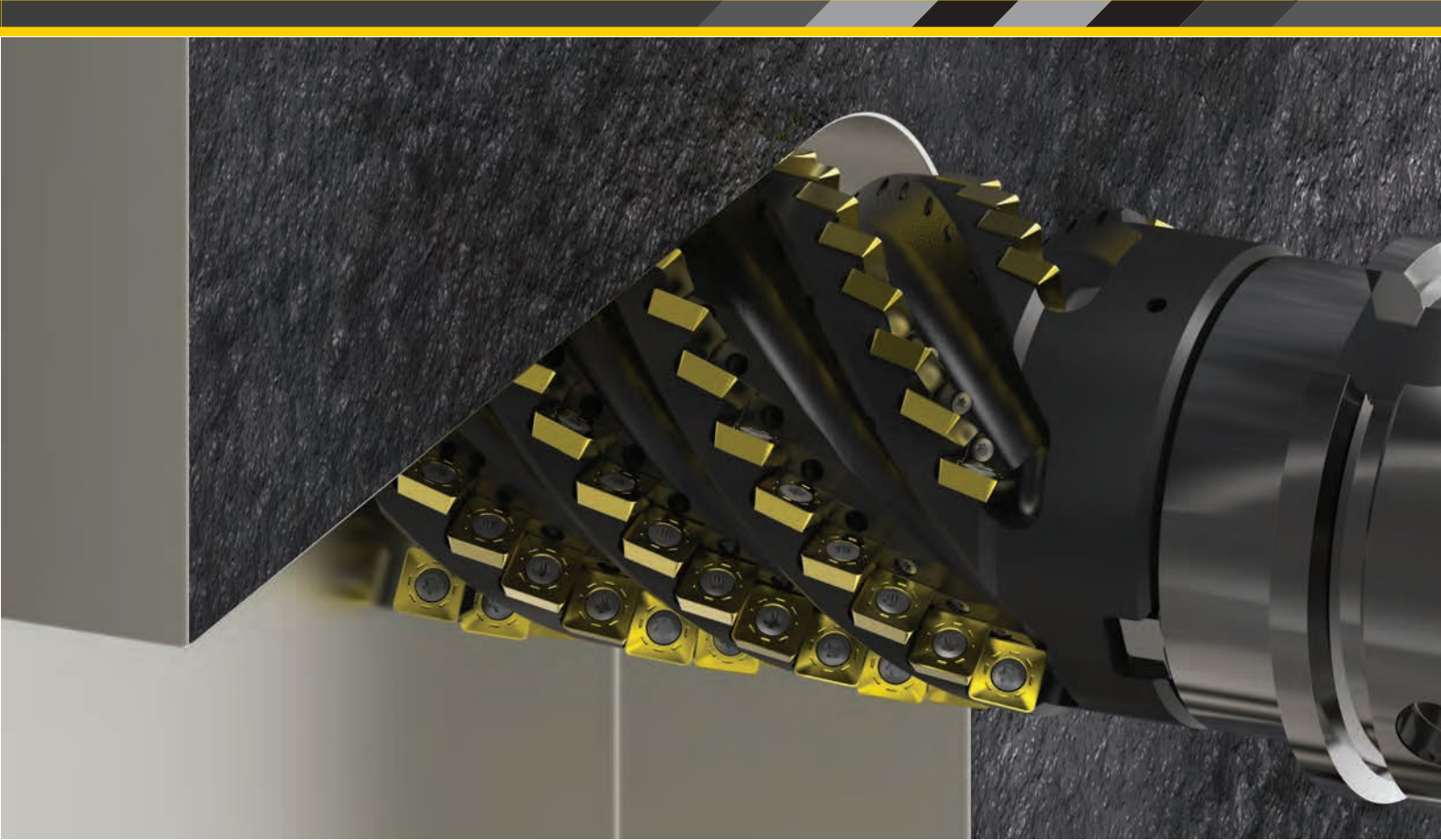

## 5230 Chevron Long Edge Milling

### Setting New Standards of Productivity

- Unique insert alignment reduces cutting forces
- Each insert has its own coolant jet for maximum chip evacuation
- Continuous engagement for maximum material removal



## The 5230VS Series: Cut Machining Time by up to 50% or More

**Shell**  
50mm – 100mm



- 90 degree roughing
- High Metal Removal Rates
- High Stability and Rigidity
- Square inserts, 4 cutting edges
- Three grades, four geometries
- Shell and Cylindrical construction
- Standard and long series available
- Cutting diameters from 50mm to 100mm
- Insert sizes 9,52mm and 12,70mm
- Depth of cut from 51mm to 133mm

### 5230 Case Histories



Material: Titanium 555-3  
Cutter: 5230VS12 (63mm Cutter)  
Component: Landing Gear  
Industry: Aerospace  
Insert Grade: X500  
RPM: 150  
Cutting Speed  $V_C$ : 29,7 m/min  
Feed per Tooth  $f_z$ : 0,1 mm/min  
Feed Rate: 60 mm/min  
Depth of Cut  $a_p$ : 50mm

***Increased Metal Removal Rate by 300%!***

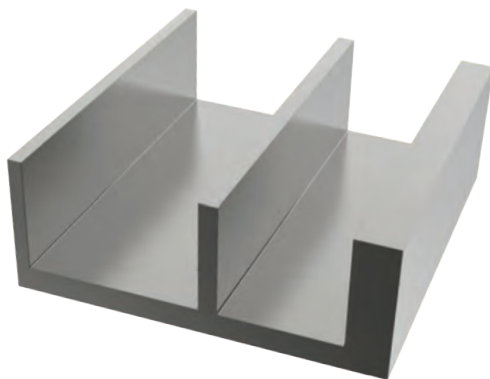

Material: Titanium 6-4  
Cutter: 5230VS12 (80mm Cutter)  
Component: Bulkhead  
Industry: Aerospace  
Insert Grade: X500  
RPM: 275  
Cutting Speed  $V_C$ : 69,0 m/min  
Feed per Tooth  $f_z$ : 0,1 mm/min  
Feed Rate: 148 mm/min  
Depth of Cut  $a_p$ : 60mm

***Incredible Metal Removal Rate of 43 in<sup>3</sup> / min.***



## Engineered from the Inside Out *Axial Engagement is the Key*

The advanced Chevron Design ensures that one cutting point is always in contact with the material during entrance and exit. This provides optimum harmonic stability, reducing power consumption and maximizing tool life.

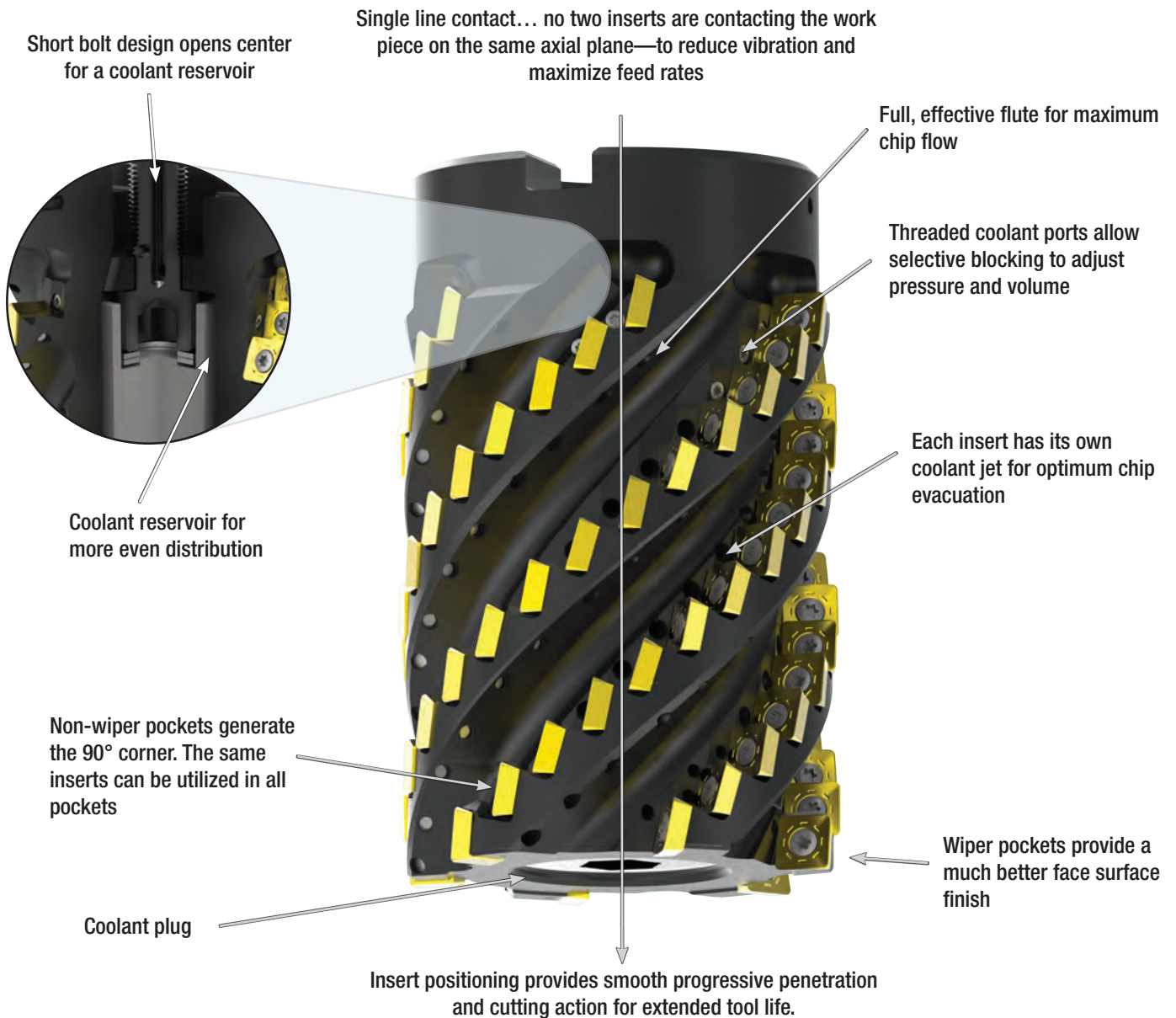



## 5230 Geometries

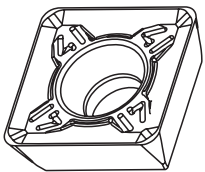

**-41**

This general purpose utility geometry has a positive cutting action and reinforced cutting edge for medium roughing and semi-finishing applications.

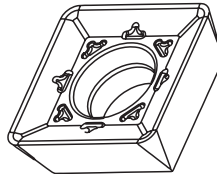

**-423**

A strong positive geometry featuring a smaller primary angle and a small controlled hone to reduce cutting pressures, followed by a higher secondary angle to allow free cutting of the chip without rubbing on the insert rake face. Chip flow compresses the chip for easy evacuation.

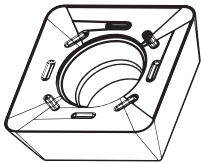

**-422**

This positive geometry features an 11° chip angle and an “E” edge preparation for roughing and semi-finishing applications in difficult to machine materials.

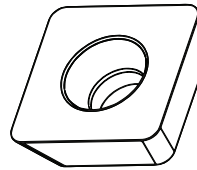

**-TN**

This geometry is a flat top design with a strong T-land edge preparation for preventing chipping in unstable conditions. It has a smaller edge preparation which reduces machine power consumption.

## 5230 Grades

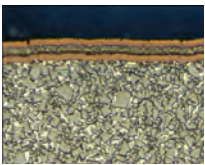

**X500**

*Coating Type: CVD, TiN-TiC-TiN, X-Grade™ Technology*

High level of shock resistance; operates at the low to medium cutting speeds; high metal removal rates while retaining a secure cutting edge.

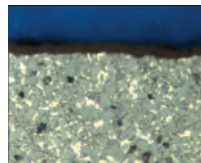

**SP6519**

*Coating Type: PVD, TiAlN*

This grade features a combination of a tough substrate with a new generation of TiAlN super nano coating, making it virtually free of residual stress and extremely hard for unmatched performance.

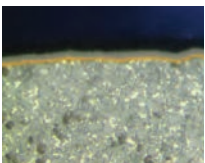

**MP91M**

*Coating Type: CVD, TiN-MT-TiCN-Al2O3*

With its Aluminium Oxide coating, this grade is recommended every time wear characteristics are more important than toughness.

## Material Guide – Key to Recommended Inserts

### Material Designation

Unalloyed Steels Alloyed Steels Stainless Steels PH Stainless Cast Irons Aluminum & Alloys High Temp. Alloys Hard Materials

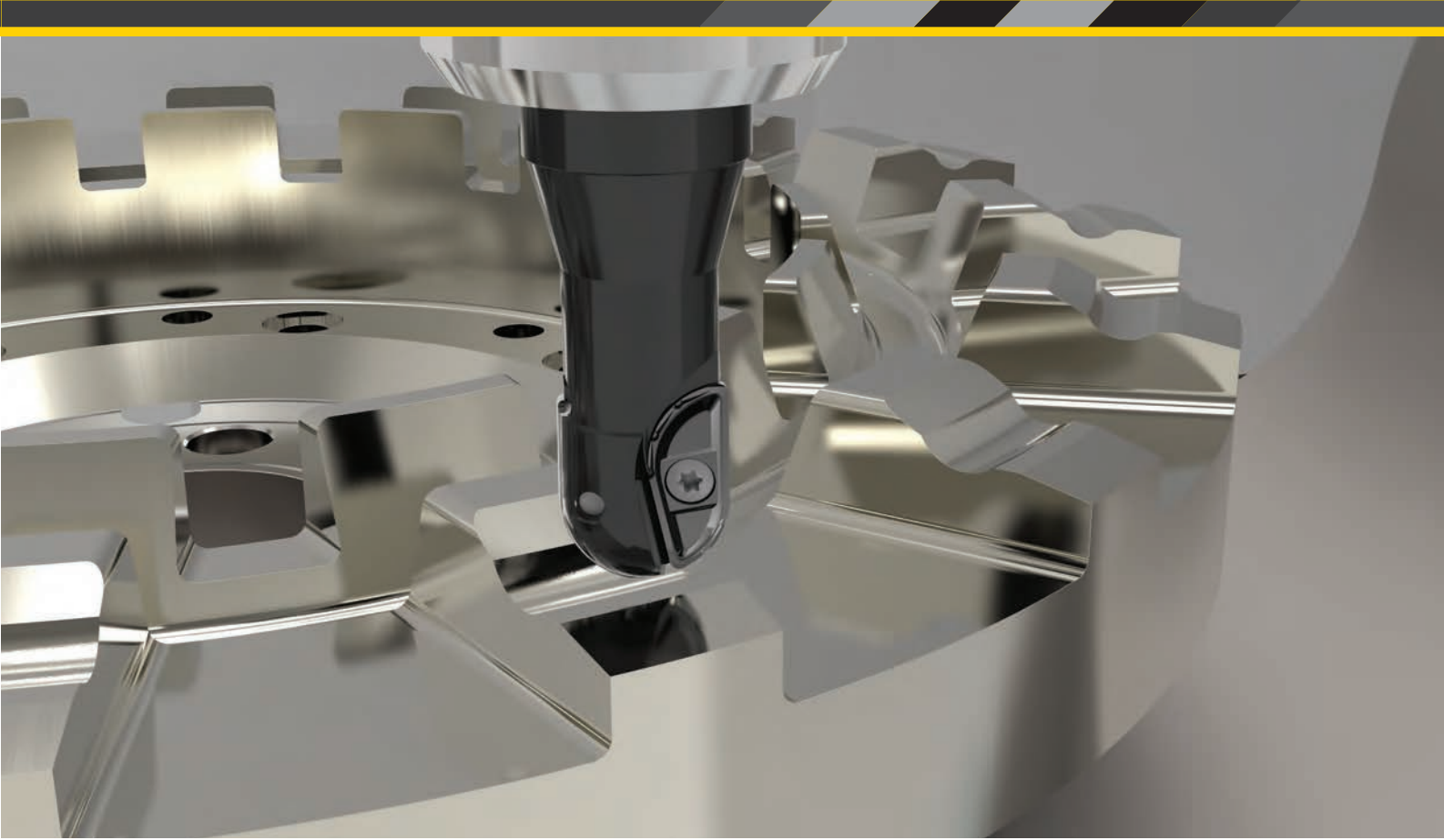

## 5505 Ball Nose Contour Milling

**Contour Milling of Mild Steels to  
High Temperature Superalloys**



## 5505VX State of the Art Ball Nose Cutters

**Weldon**  
20mm – 50mm



- Reinforced design for heavy machining
- High volume of chip cutting
- Excellent chip control and evacuation

**Cylindrical**  
16mm – 32mm



5505VX Ball Nose Cutters are ideal for roughing and semi-finishing of profiles and complex contours in Steel, Alloyed Steel, Stainless Steel, High Temperature Alloys and Cast Iron.

- One grade, one geometry does it all
- Helical insert design and rigid fixation for increased speeds and feeds
- Double edge insert is indexable for reduced inventory
- Slotting to full radius

**Modular**  
16mm – 32mm



## Case History

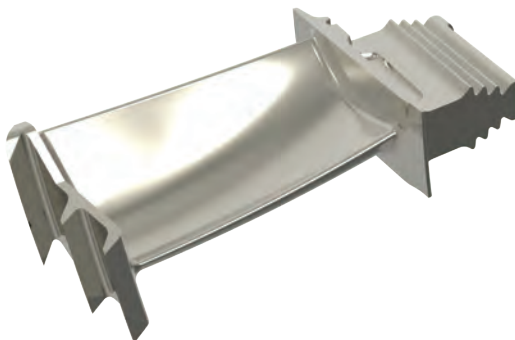

Material: Stainless Steel 403  
Cutter: 5505VX (25mm Cutter)  
Component: Turbine Blade  
Industry: Power Generation  
Insert Grade: SP6519  
RPM: 2293  
Cutting Speed  $V_C$ : 183 m/min  
Feed per Tooth  $f_z$ : 0,28mm  
Feed Rate: 1285 mm/min  
Depth of cut  $a_p$ : 3,18mm

**40% Increase in Productivity**



## 5505VX Heavy Duty Ball Nose Cutters





## Case History



Material: Titanium 6-4  
 Component: Valve Body  
 Industry: Oil & Gas  
 Cutter: 5505VX (25mm Cutter)  
 Insert Grade: SP6519  
 RPM: 1469  
 Cutting Speed  $V_C$ : 115 m/min  
 Feed per Tooth  $f_z$ : 0,135mm  
 Feed Rate: 395,3 mm/min  
 Depth of cut  $a_p$ : 1,5mm

**Helical Interpolation Doubled Productivity**

## Ball Nose Geometry

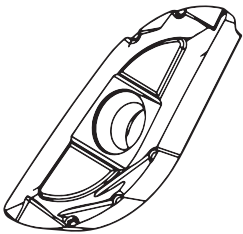

**-F**

This geometry is a roughing ball nose fully ground insert for roughing and semi-finishing of all materials except Aluminium. This geometry is designed with chip grooves for better chip control.

## Ball Nose Grade

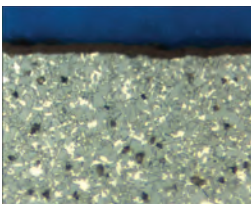

**SP6519**

Coating Type: PVD, TiAlN

The combination of a tough substrate with a new generation of TiAlN super nano coating, makes this new PVD coating virtually free of residual stress and extremely hard for unmatched performance.

Primarily used in Stainless Steel, High Temperature Alloys & Titanium with stable conditions. Also can be used in Steel, Steel Alloys and Cast Irons.

## Material Guide – Key to Recommended Inserts

### Material Designation

Unalloyed Steels Alloyed Steels Stainless Steels PH Stainless Cast Irons Aluminum & Alloys High Temp. Alloys Hard Materials



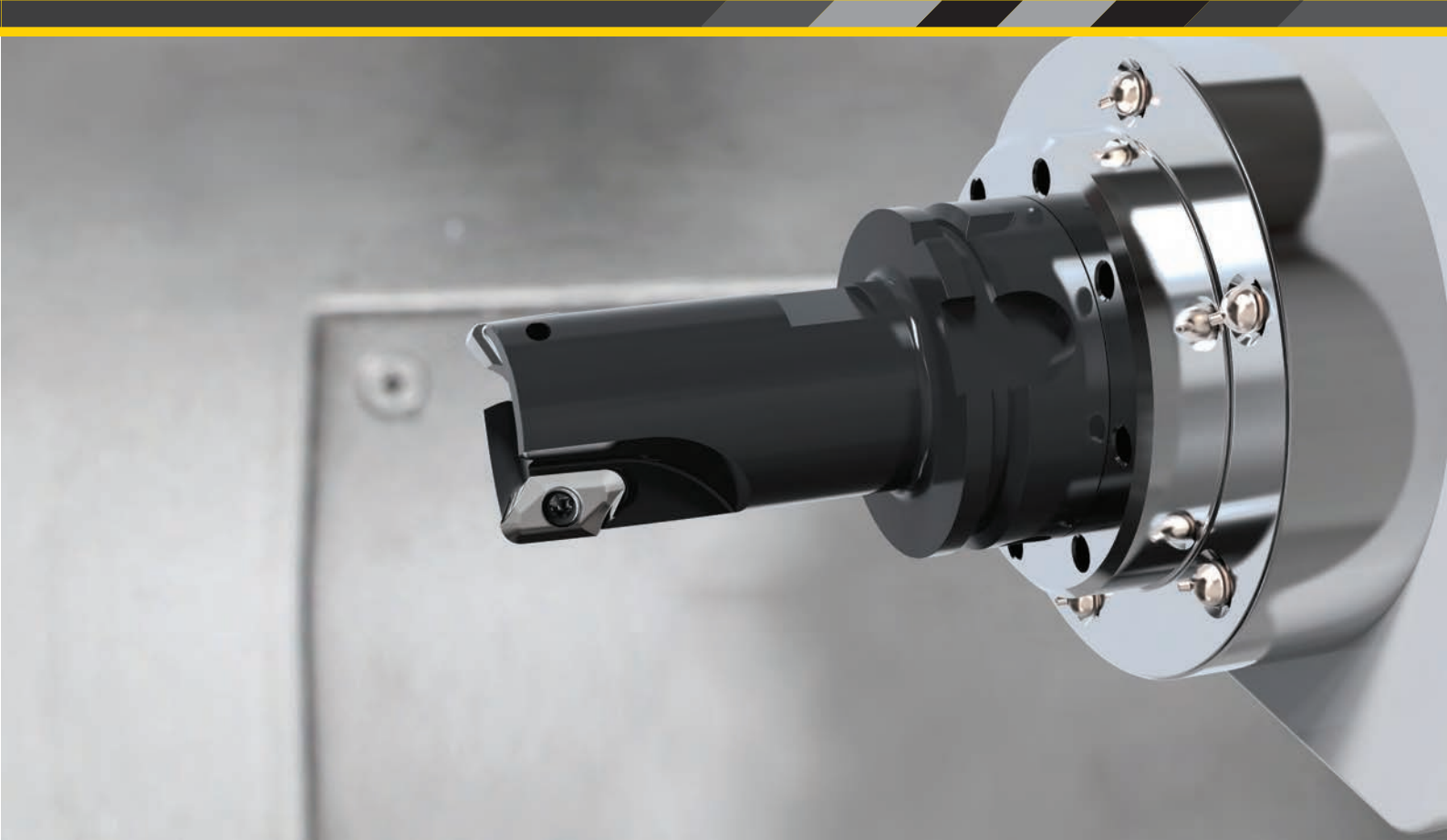

## 5720 Patented Profile Pocket Milling: Aluminium

**Taking extreme high speed aluminium machining to the highest level**



## 5720 Patented Series High Speed Aluminium Cutters

**5720 Up to 51000 RPM**

**Cylindrical**

25mm – 32mm



**Shell**

40mm – 80mm



**Modular**

25mm – 32mm



### Extreme Metal Removal to fit your application

- Especially designed for machining pockets and profiles on Aluminium and Aluminium Alloys
- The 5720 is designed, manufactured and tested in accordance with EN ISO 15641:2001 to ensure maximum stability in high speed applications
- Each features internal coolant allowing better chip evacuation and higher feed rates.
- The pockets are reinforced to allow for heavy feeding and safe ramping during machining
- Excellent tools for thin-walled machining
- HSK specials available upon request

Cylindrical Shank and special HSK Integral Shanks are balanced to G6.3 @ 30000 RPM for diameters up to 50mm. Diameters larger than 50mm are balanced to G6.3 @ 24000 RPM.

5720 inserts: 12 different radii are available, each with the same cutting depth capacity of 16mm



## 5720 Patented Series Extreme High Speed Aluminium Cutters





## 5720 Case History



Material: Aluminium 2024  
 Cutter: 5720VZ (32mm Cutter)  
 Component: Seat Support  
 Industry Segment: Aerospace  
 Insert Grade: GH1  
 Spindle Speed: 17491 RPM  
 Cutting Speed  $V_C$ : 1758 m/min  
 Feed per Tooth  $f_z$ : 0,25mm  
 Feed rate: 8745 mm/min  
 Depth of Cut: 2,5mm

**Result: 400% Increase in Productivity**

## 5720 High Speed Geometry

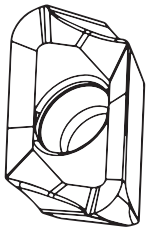

**-721**

This extreme high positive geometry is highly suitable for machining Aluminium Alloys, Copper and Brass. This geometry is periphery ground with a pressed, polished top rake face reducing built up edge. Especially qualified when machining thin-walled components.

## High Speed Grade

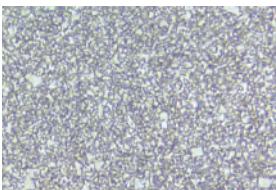

**GH1**

*Uncoated, Micrograin*

This micrograin grade is designed for use on Aluminium Alloys, Copper, Brass and Kevlar etc. The grade GH1 works well with or without coolant with low cutting pressure at high speeds due to sharp cutting edge.

## Material Guide – Key to Recommended Inserts

### Material Designation

Unalloyed Steels  
 Alloyed Steels  
 Stainless Steels  
 PH Stainless  
 Cast Irons  
 Aluminum & Alloys  
 High Temp. Alloys  
 Hard Materials



## 5702 High Speed Aluminium Cutters

Outstanding performance in a 20mm cutter



## 5702 Series High Speed Aluminium Cutters

5702 Up to 43000 RPM  
Cylindrical  
20mm



### Extreme Metal Removal to fit your application

- Especially designed for machining pockets and profiles on Aluminium and Aluminium Alloys
- Designed, manufactured and tested in accordance with EN ISO 15641:2001 to ensure maximum stability in high speed applications
- Through-tool coolant allowing better chip evacuation and higher feed rates
- Pockets are reinforced to allow for heavy feeding and safe ramping during machining
- Excellent tools for thin-walled machining
- HSK specials available upon request
- 12mm depth of cut
- 5 radii available
- -701 fully ground geometry ideal for high speed Aluminium milling
- Balanced to G6.3 @ 30000 RPM

## 5702 Case History



Material: Aluminium Alloy 7175  
Component: Airframe  
Industry Segment: Aerospace  
Tool: 5702VZD (20mm Cutter)  
Insert Grade: GH2  
Cutting Speed  $V_C$ : 754 m/min  
Spindle Speed: 12000 RPM  
Feed per Tooth  $f_z$ : 0,25mm  
Feedrate: 6000 mm/min

***Precision inserts provide excellent results in thin-wall machining applications while yielding superior surface finishes***



## 5702 Precision High Speed Aluminium Cutter



### 5702 Geometry

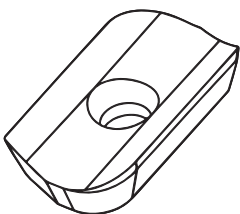

#### -701

This extreme high positive geometry is highly suitable for machining Aluminium Alloys, Copper and Brass. The -701 geometry is precision ground and gives excellent performance when machining thin-walled components.

### 5702 Grade

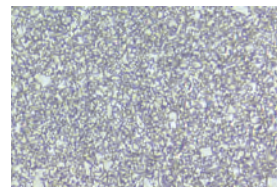

#### GH1

*Uncoated, Micrograin*

This micrograin grade is designed for use on Aluminium Alloys, Copper, Brass and Kevlar, etc. The grade GH1 works well with or without coolant with low cutting pressure at high speeds due to sharp cutting edge.

### Material Guide – Key to Recommended Inserts

#### Material Designation

 Unalloyed Steels  
  Alloyed Steels  
  Stainless Steels  
  PH Stainless  
  Cast Irons  
  Aluminum & Alloys  
  High Temp. Alloys  
  Hard Materials

**WORLD HEADQUARTERS**

**Kennametal Inc.**

1600 Technology Way

Latrobe, PA 15650

USA

Tel: 800.446.7738 (United States and Canada)

E-mail: [ftmill.service@kennametal.com](mailto:ftmill.service@kennametal.com)

**EUROPEAN HEADQUARTERS**

**Kennametal Europe GmbH**

Rheingoldstrasse 50

CH 8212 Neuhausen am Rheinfall

Switzerland

Tel: 41.52.6750.100

E-mail: [neuhausen.info@kennametal.com](mailto:neuhausen.info@kennametal.com)

**ASIA-PACIFIC HEADQUARTERS**

**Kennametal (Singapore) Pte. Ltd.**

3A International Business Park

Unit #01-02/03/05, ICON@IBP

Singapore 609935

Tel: 65.6265.9222

E-mail: [k-sg.sales@kennametal.com](mailto:k-sg.sales@kennametal.com)

**INDIA HEADQUARTERS**

**Kennametal India Limited**

8/9th Mile, Tumkur Road

Bangalore - 560 073

Tel: 91.80.2839.4321

E-mail: [bangalore.information@kennametal.com](mailto:bangalore.information@kennametal.com)



Kennametal Inc.

1600 Technology Way

Latrobe, PA 15650

USA

[www.kennametal.com](http://www.kennametal.com)