

KANTER





**KLEMMHALTER/BOHRSTANGEN
TURNING TOOLS
PORTE-PLAQUETTES
PORTAINSERTI
ТОКАРНЫЙ ИНСТРУМЕНТ**

**EINBAUHALTER
CARTRIDGES
CARTOUCHES
CARTUCCE
КАРТРИДЖИ**

VIV-BLOCK-SYSTEM



EINBAUHALTER CARTOUCHES
 CARTRIDGES CARTUCCE
 КАРТРИДЖИ

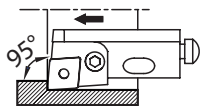

PCLN

Page 433

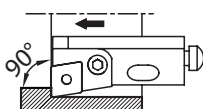

PCFN

Page 433

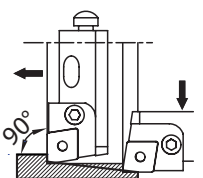

PCGN

Page 434

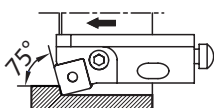

PSKN

Page 434

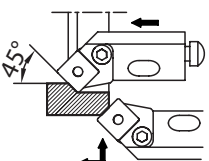

PSSN

Page 435

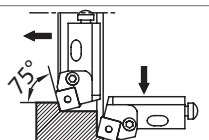

PSRN

Page 435

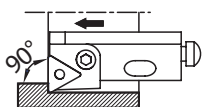

PTFN

Page 436

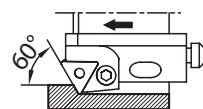

PTWN

Page 436

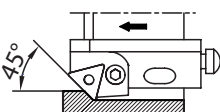

PTSN

Page 437

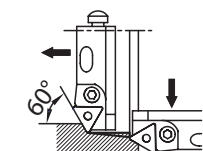

PTTN

Page 437

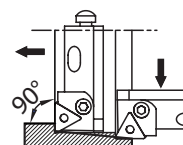

PTGN

Page 438

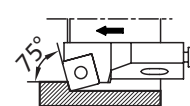

SSKC

Page 438

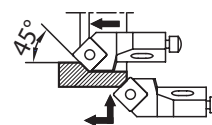

SSSC

Page 439

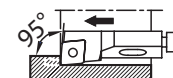

SCLC

Page 439

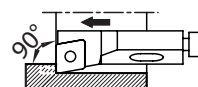

SCFC

Page 439

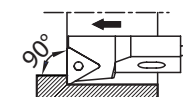

STFC

Page 440

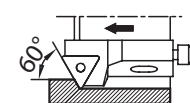

STWC

Page 440

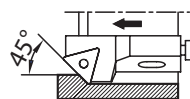

STSC

Page 440

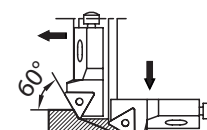

STTC

Page 441

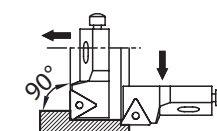

STGC

Page 441

KLEMMHALTER FÜR DIE AUSSENBEARBEITUNG VLV-BLOCK PORTA-PLAQUETTES EXTERIEURES VLV-BLOCK
 ESTERNAL (O.D.) TURNING TOOLS VLV-BLOCK PORTA INSERTI PER ESTERNI VLV-BLOCK
 ДЕРЖАВКИ ДЛЯ ВНЕШНЕГО ТОЧЕНИЯ VLV-BLOCK

VCLN

Page 444

VSBN

Page 445

VCBN

Page 444

VSSN

Page 445

KLEMMHALTER FÜR DIE AUSSENBEARBEITUNG PORTA-PLAQUETTES EXTERIEURES
 ESTERNAL (O.D.) TURNING TOOLS PORTA INSERTI PER ESTERNI
 ДЕРЖАВКИ ДЛЯ ВНЕШНЕГО ТОЧЕНИЯ

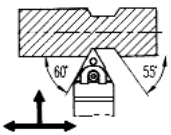

MTEN

Page 449

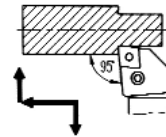

PCLN

Page 452

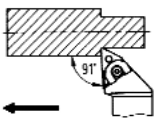

MTGN

Page 449

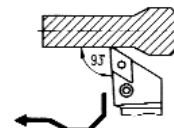

PDJN

Page 452

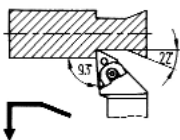

MTJN

Page 450

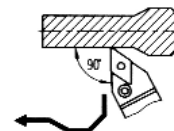

PDNN

Page 453

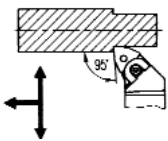

MWLN

Page 450

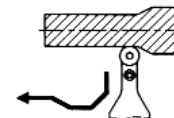

PRDC

Page 453

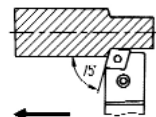

PCBN

Page 451

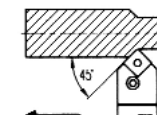

PSDN

Page 454

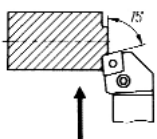

PCKN

Page 451

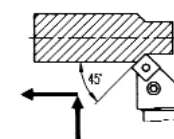

PSSN

Page 454

KLEMMHALTER FÜR DIE AUSSENBEARBEITUNG PORTA-PLAQUETTES EXTERIEURES
 EXTERNAL (O.D.) TURNING TOOLS PORTA INSERTI PER ESTERNI
 ДЕРЖАВКИ ДЛЯ ВНЕШНЕГО ТОЧЕНИЯ

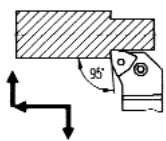

PWLN

Page 455

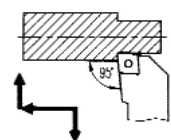

SCLC

Page 455

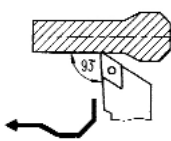

SDJC

Page 456

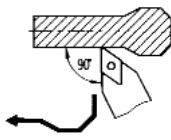

SDNC

Page 456

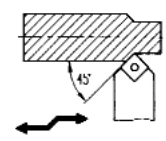

SSDC

Page 457

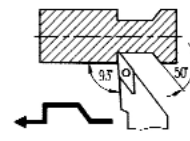

SVJB

Page 458

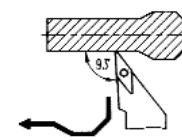

SVJC

Page 458

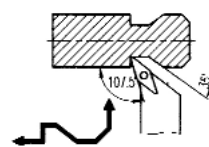

SVHB

Page 459

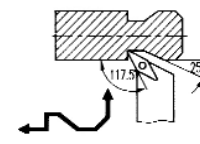

SVPB

Page 459

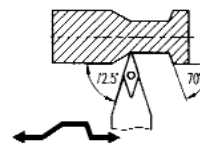

SVVB

Page 460

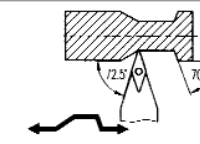

SVVC

Page 460

BOHRSTANG FÜR INNENBEARBEITUNG BARRES D'ALEPAGE
 INTERNAL (I.D.) BORING BARS BARENI PER INTERNI
 РАСТОЧНЫЕ ДЕРЖАВКИ

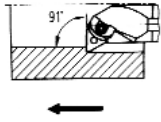

MTFN

Page 462

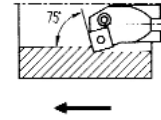

PSKN

Page 464

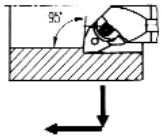

MWLN

Page 462

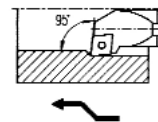

SCLC

Page 464

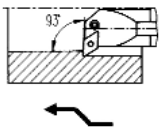

PCLN

Page 463

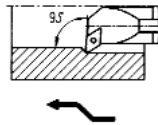

SDUC

Page 465

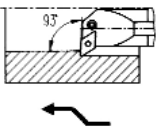

PDUN

Page 463

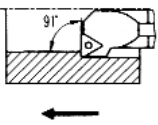

STFC

Page 465

BESTELNUMMERN-SCHLÜSSEL FÜR EINBAUHALTER CODIFICATION DES CARTOUCHES
 CODE KEY FOR CARTRIDGES CHIAVE DEI CODICI DELLE CARTUCCE
 СИСТЕМА ОБОЗНАЧЕНИЯ КАРТРИДЖЕЙ

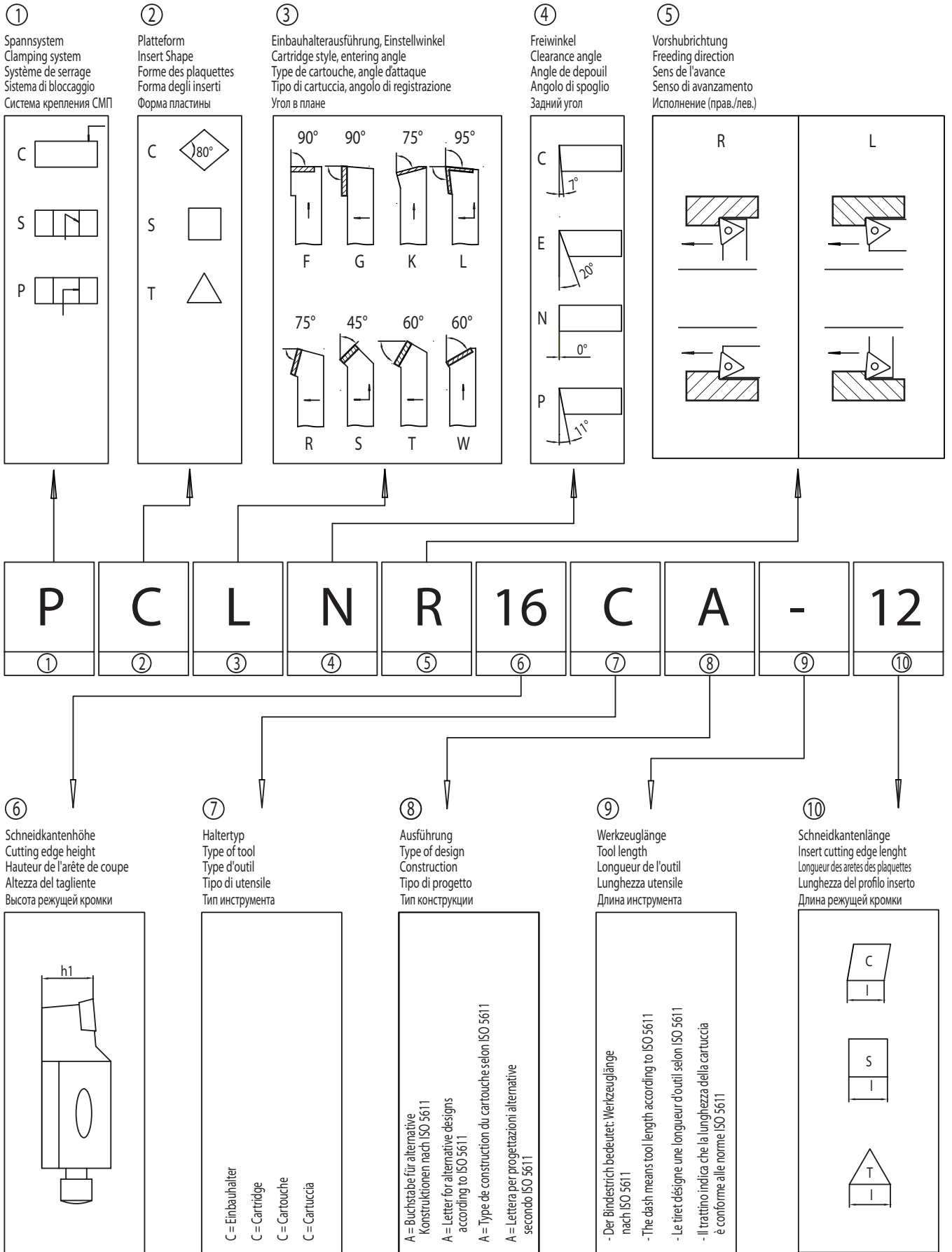

PCLN

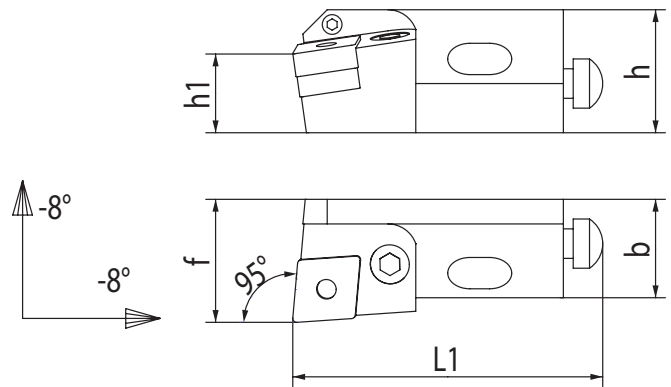

Code N.	h	h1	b	L1	f	Dmin.	Inserts N.	Support pad	Lever	Screw	Shim pin	Chiave
PCLNR/L 12CA-12	20	12	15	55	20	50	CNM..1204..		K114	K124		2.5
PCLNR/L 16CA-12	25	16	20	63	25	55	CNM..1204..	KA1	K112	K122	KD1	3
PCLNR/L 20CA-16	30	20	20	70	25	70	CNM..1606..	KY2	KB5	KC5c	KD5	3
PCLNR/L 25CA-19	38	25	25	100	32	100	CNM..1906..	KA2	K113	K123	K131	4

PCFN

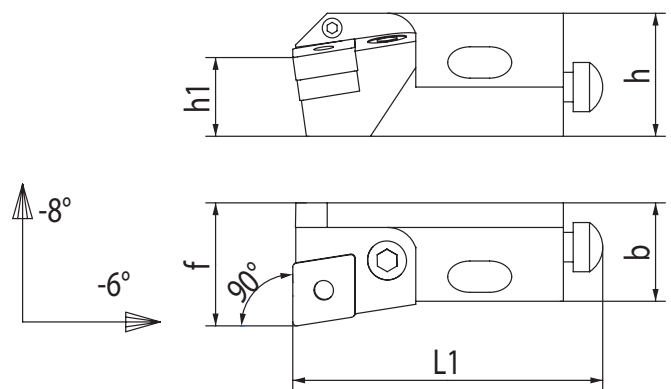

Code N.	h	h1	b	L1	f	Dmin.	Inserts N.	Support pad	Lever	Screw	Shim pin	Chiave
PCFNR/L 12CA-12	20	12	15	55	20	50	CNM..1204..		K114	K124		2.5
PCFNR/L 16CA-12	25	16	20	63	25	55	CNM..1204..	KA1	K112	K122	KD1	3
PCFNR/L 20CA-16	30	20	20	70	25	70	CNM..1606..	KY2	KB5	KC5c	KD5	3
PCFNR/L 25CA-19	38	25	25	100	32	100	CNM..1906..	KA2	K113	K123	K131	4

PCGN

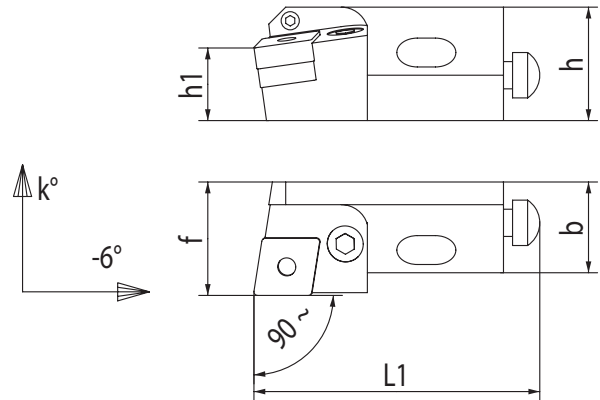

Code N.	h	h1	b	L1	f	Dmin.	k	Inserts N.	Support pad	Lever	Screw	Shim pin	Chiave
PCGNR/L 16CA-12	25	16	20	63	25	60	-10°	CNM..1204..	KA1	K112	K122	KD1	3
PCGNR/L 25CA-19	38	25	25	100	32	100	-8°	CNM..1906..	KA2	K113	K123	K131	4

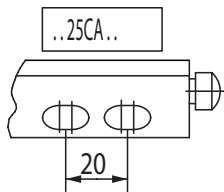

Ricambi cartucce per ...	Screw	Chiave	Screw	Screw	Chiave
..12CA..	KGRL12	2	KVA5	KVB12	4
..16CA..	KGRL16	2.5	KVA6	KVB16	5
..20CA..	KGRL20	2.5	KVA6	KVB20	5
..25CA..	KGRL25	3	KVA8	KVB25(n°2)	6

PSKN

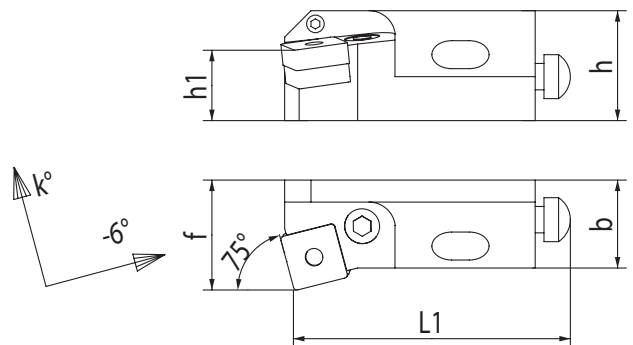

Code N.	h	h1	b	L1	f	Dmin.	k	Inserts N.	Support pad	Lever	Screw	Shim pin	Chiave
PSKNR/L 12CA-12	20	12	15	55	20	50	-8°	SNM..1204..		K114	K124		2.5
PSKNR/L 16CA-12	25	16	20	63	25	55	-7°	SNM..1204..	KA4	K112	K122	KD1	3
PSKNR/L 20CA-15	30	20	20	70	25	70	-8°	SNM..1506..	KY1	KB5	KC5c	KD5	3
PSKNR/L 25CA-19	38	25	25	100	32	100	-7°	SNM..1906..	KA5	K113	K123	K131	4

PSSN

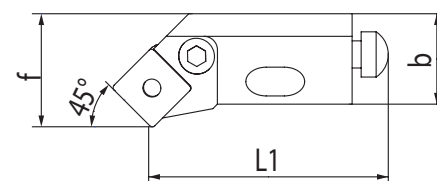
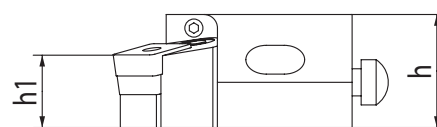

Code N.	h	h1	b	L1	f	Dmin.	k1	k2	Inserts N.	Support pad	Lever	Screw	Shim pin	Chiave
PSSNR/L 12CA-12	20	12	15	47	20	50	-3°	-10°	SNM..1204..					
PSSNR/L 16CA-12	25	16	20	53	25	55	0°	-11°	SNM..1204..	KA4	K112	K122	KD1	3
PSSNR/L 20CA-15	30	20	20	60	25	70	-3°	-10°	SNM..1506..	KY1	KB5	KC5c	KD5	3

PSRN

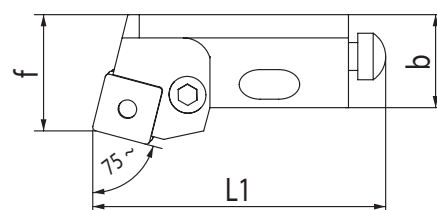
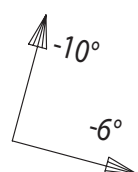
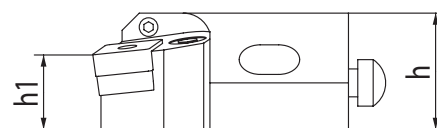

Code N.	h	h1	b	L1	f	Dmin.	Inserts N.	Support pad	Lever	Screw	Shim pin	Chiave
PSRNR/L 16CA-12	25	16	20	63	25	60	SNM..1204..					
PSRNR/L 20CA-15	30	20	20	70	25	70	SNM..1506..	KA4	K112	K122	KD1	3
								KY1	KB5	KC5c	KD5	3

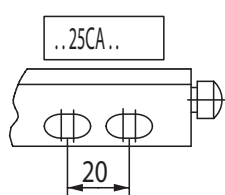

Ricambi cartucce per ...	Screw	Chiave	Screw	Screw	Chiave
..12CA..	KGRL12	2	KVA5	KVB12	4
..16CA..	KGRL16	2.5	KVA6	KVB16	5
..20CA..	KGRL20	2.5	KVA6	KVB20	5
..25CA..	KGRL25	3	KVA8	KVB25(n°2)	6

PTFN

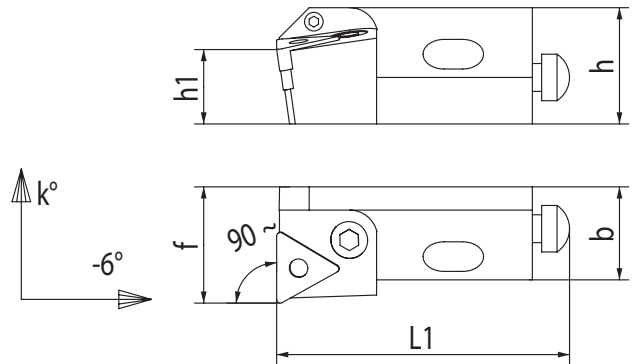

Code N.	h	h1	b	L1	f	Dmin.	k	Inserts N.	Support pad	Lever	Screw	Shim pin	Chiave
PTFNR/L 12CA-16	20	12	15	55	20	50	-9°	TNM..1604..					
PTFNR/L 16CA-16	25	16	20	63	25	55	-8°	TNM..1604..	KA6	KB4	KC3	KD3	2.5
PTFNR/L 20CA-22	30	20	20	70	25	70	-8°	TNM..2204..	KA7	KB1	KC1	KD1	3
PTFNR/L 25CA-27	38	25	25	100	32	100	-9°	TNM..2706..	KH1	KH2	KH5	KD5	3

PTWN

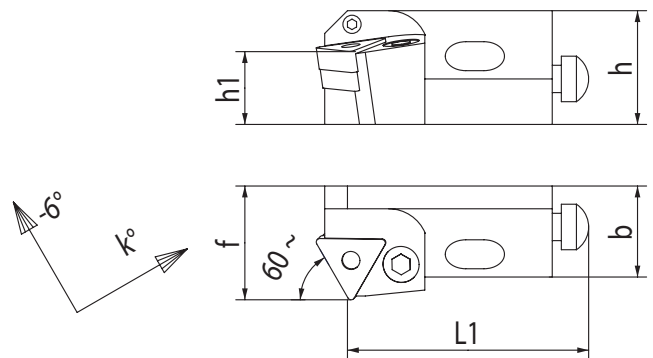

Code N.	h	h1	b	L1	f	Dmin.	k	Inserts N.	Support pad	Lever	Screw	Shim pin	Chiave
PTWNR/L 12CA-16	20	12	15	47	20	50	-7°	TNM..1604..					
PTWNR/L 16CA-16	25	16	20	53	25	55	-6°	TNM..1604..	KA6	KB4	KC3	KD3	2.5
PTWNR/L 20CA-22	30	20	20	60	25	70	-6°	TNM..2204..	KA7	KB1	KC1	KD1	3

PTSN

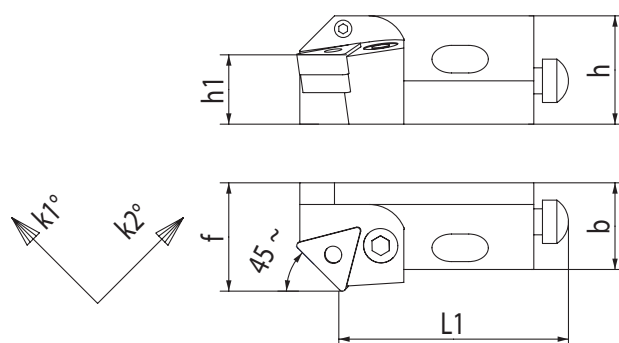

Code N.	h	h1	b	L1	f	Dmin.	k1	k2	Inserts N.	Support pad	Lever	Screw	Shim pin	Chiave
PTSNR/L 12CA-16	20	12	15	47	20	50	-3°	-10°	TNM..1604..		K111	K121		2
PTSNR/L 16CA-16	25	16	20	53	25	55	0°	-11°	TNM..1604..	KA6	KB4	KC3	KD3	2.5
PTSNR/L 20CA-22	30	20	20	60	25	70	0°	-11°	TNM..2204..	KA7	KB1	KC1	KD1	3

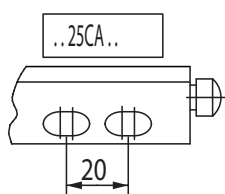

Ricambi cartucce per ...	Screw	Chiave	Screw	Screw	Chiave
..12CA..	KGRL12	2	KVA5	KVB12	4
..16CA..	KGRL16	2.5	KVA6	KVB16	5
..20CA..	KGRL20	2.5	KVA6	KVB20	5
..25CA..	KGRL25	3	KVA8	KVB25(n°2)	6

PTTN

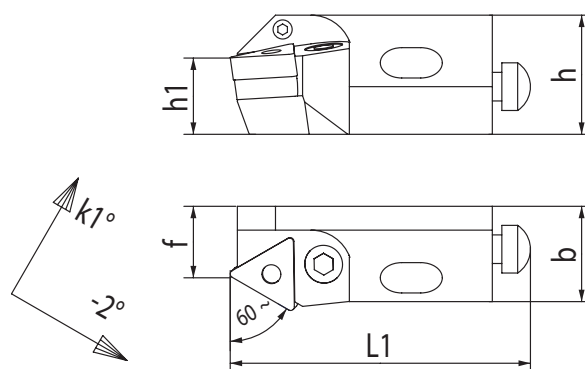

Code N.	h	h1	b	L1	f	Dmin.	k	Inserts N.	Support pad	Lever	Screw	Shim pin	Chiave
PTTNR/L 12CA-16	20	12	15	55	13	50	-9°	TNM..1604..		K111	K121		2
PTTNR/L 16CA-16	25	16	20	63	15	60	-10°	TNM..1604..	KA6	KB4	KC3	KD3	2.5
PTTNR/L 20CA-22	30	20	20	70	15	70	-10°	TNM..2204..	KA7	KB1	KC1	KD1	3

PTGN

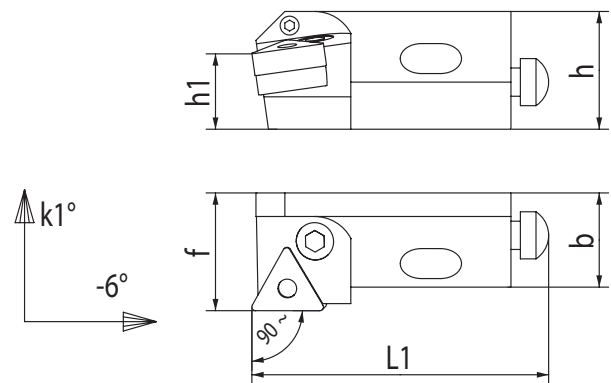

Code N.	h	h1	b	L1	f	Dmin.	k	Inserts N.	Support pad	Lever	Screw	Shim pin	Chiave
PTGNR/L 12CA-16	20	12	15	55	20	50	-10°	TNM..1604..					
PTGNR/L 16CA-16	25	16	20	63	25	60	-10°	TNM..1604..	KA6	KB4	KC3	KD3	2.5
PTGNR/L 20CA-22	30	20	20	70	25	70	-8°	TNM..2204..	KA7	KB1	KC1	KD1	3

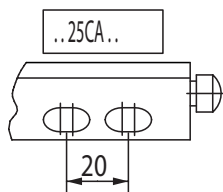

Ricambi cartucce per ...	Screw	Chiave	Screw	Screw	Chiave
..12CA..	KGRL12				
..16CA..	KGRL16	2	KVA5	KVB12	4
..20CA..	KGRL20	2.5	KVA6	KVB16	5
..25CA..	KGRL25	2.5	KVA6	KVB20	5
		3	KVA8	KVB25(n°2)	6

SSKC

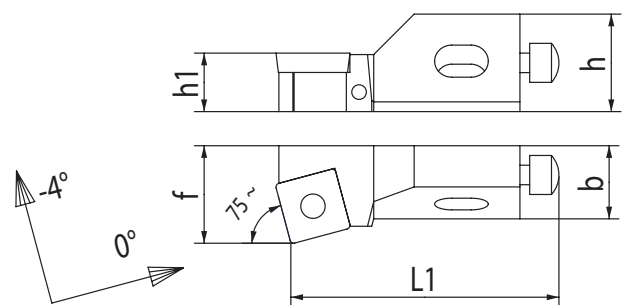

Code N.	h	h1	b	L1	f	Dmin.	Inserts N.	Screw	Wrench
SSKCR/L 10CA-09	15	10	11	50	14	40	SCM..09T3..		
SSKCR/L 12CA-12	20	12	15	55	20	50	SCM..1204..	KV4c KV5	Torx 15 Torx 20

SSSC

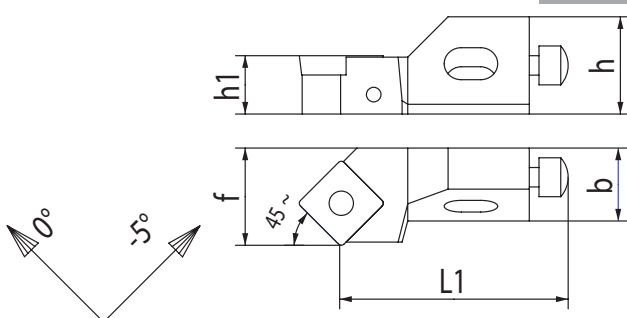

Code N.	h	h1	b	L1	f	Dmin.	Inserts N.
---------	---	----	---	----	---	-------	------------

SSSCR/L 10CA-09	15	10	11	44	14	40	SCM..09T3..
SSSCR/L 12CA-12	20	12	15	47	20	50	SCM..1204..

Screw	Wrench
-------	--------



KV4c

Torx 15

KV5

Torx 20

SCLC

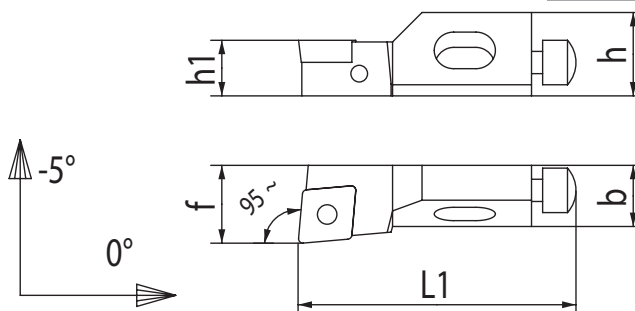

Code N.	h	h1	b	L1	f	Dmin.	Inserts N.
---------	---	----	---	----	---	-------	------------

SCLCR/L 10CA-09	15	10	11	50	14	40	CCM..09T3..
-----------------	----	----	----	----	----	----	-------------

Screw	Wrench
-------	--------



KV4c

Torx 15

SCFC

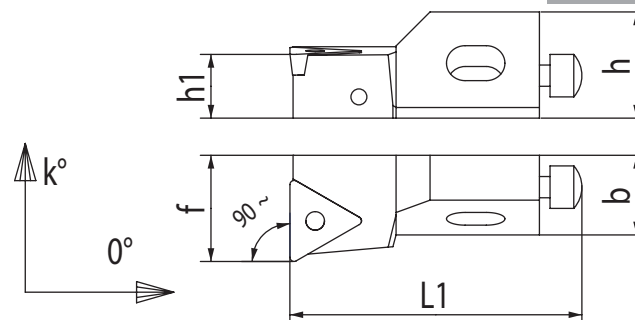

Code N.	h	h1	b	L1	f	Dmin.	Inserts N.
---------	---	----	---	----	---	-------	------------

SCFCR/L 10CA-09	15	10	11	50	14	40	CCM..09T3..
-----------------	----	----	----	----	----	----	-------------

Screw	Wrench
-------	--------



KV4c

Torx 15

Ricambi cartucce per ...	Screw	Chiave	Screw	Screw	Chiave
..10CA..	KGR10	2	KVA5	KVB10	4
..12CA..	KGR12	2	KVA5	KVB12	4



STFC

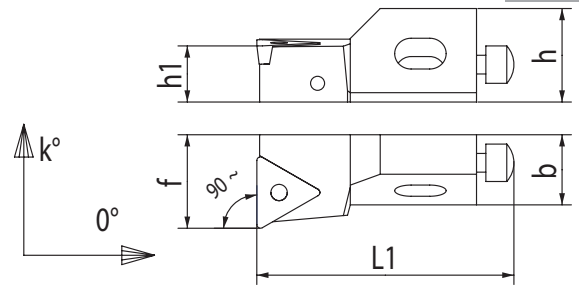

Code N.	h	h1	b	L1	f	Dmin.	k	Inserts N.	Screw	Wrench	Support pad	Bush	Chiave
STFCR/L 10CA-11	15	10	11	50	14	40	-3°	TCM..1102..	KV25	Torx 7			
STFCR/L 12CA-16	20	12	15	55	20	50	-3°	TCM..16T3..	KV4c	Torx 15			
STFCR/L 16CA-16	21	16	20	63	25	55	-6°	TCM..16T3..	KV35	Torx 15	KW3	KX01	3.5

STWC

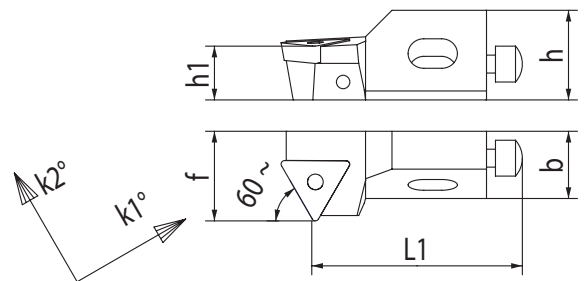

Code N.	h	h1	b	L1	f	Dmin.	k1	k2	Inserts N.	Screw	Wrench	Support pad	Bush	Chiave
STWCR/L 10CA-11	15	10	11	44	14	40	0°	-4°	TCM..1102..	KV25	Torx 7			
STWCR/L 12CA-16	20	12	15	47	20	50	-5°	0°	TCM..16T3..	KV4c	Torx 15			
STWCR/L 16CA-16	21	16	20	53	25	55	-5°	-5°	TCM..16T3..	KV35	Torx 15	KW3	KX01	3.5

STSC

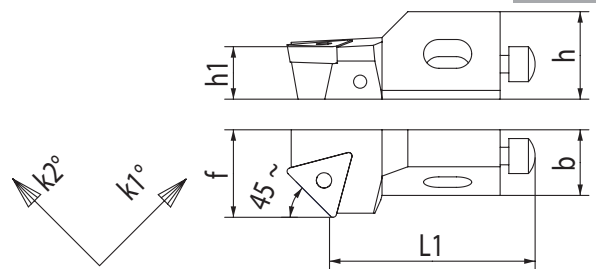

Code N.	h	h1	b	L1	f	Dmin.	k1	k2	Inserts N.	Screw	Wrench	Support pad	Bush	Chiave
STSCR/L 10CA-11	15	10	11	44	14	40	-4°	0°	TCM..1102..	KV25	Torx 7			
STSCR/L 12CA-16	20	12	15	47	20	50	-5°	0°	TCM..16T3..	KV4c	Torx 15			
STSCR/L 16CA-16	21	16	20	53	25	55	-6°	-3°	TCM..16T3..	KV35	Torx 15	KW3	KX01	3.5

Ricambi cartucce per ...	Screw	Chiave	Screw	Screw	Chiave
..10CA..	KGR10	2	KVA5	KVB10	4
..12CA..	KGR12	2	KVA5	KVB12	4
..16CA..	KGR16	2	KVA6	KVB16	5



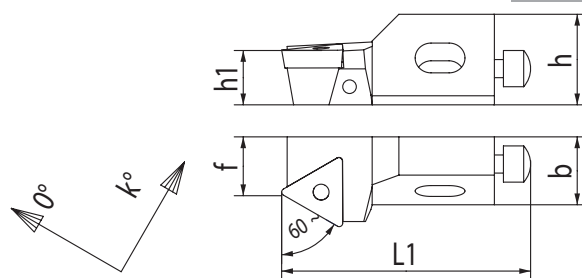

STTC



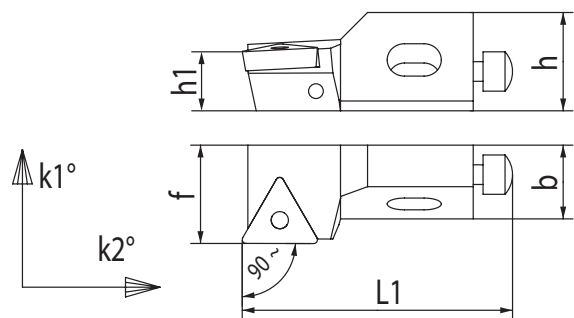



Code N.	h	h1	b	L1	f	Dmin.	k	Inserts N.	Screw	Wrench	Support pad	Bush	Chiave
STTCR/L 10CA-11	15	10	11	50	9	40	-5°	TCM..1102..					
STTCR/L 12CA-16	20	12	15	55	13	50	-3°	TCM..16T3..	KV4c	Torx 15			
STTCR/L 16CA-16	21	16	20	63	15	60	-5°	TCM..16T3..	KV35	Torx 15	KW3	KX01	3.5

STGC



Code N.	h	h1	b	L1	f	Dmin.	k1	k2	Inserts N.	Screw	Wrench	Support pad	Bush	Chiave
STGCR/L 10CA-11	15	10	11	50	14	40	-3°	0°	TCM..1102..					
STGCR/L 12CA-16	20	12	15	55	20	50	-3°	0°	TCM..16T3..	KV4c	Torx 15			
STGCR/L 16CA-16	21	16	20	63	25	60	-5°	-3°	TCM..16T3..	KV35	Torx 15	KW3	KX01	3.5

Ricambi cartucce per ...	Screw	Chiave	Screw	Screw	Chiave
..10CA..	KGR10				
..12CA..	KGR12	2	KVA5	KVB10	4
..16CA..	KGR16	2	KVA6	KVB16	5



VLV-BLOCK SYSTEM®

VLV FÜR GROBE WENDEPLATTEN

Das VLV-BLOCK Spannung System entspricht die traditionelle Kniehebel/Pratze Spannung.

Anstatt der Pratze wird eine einfache Schraube verwendet.

Auf diese Weise wird die gleiche feste Spannung versichert.

Dieses flexibel System ermöglicht auf dem gleichen Klemmhalter die Verwendung von Hartmetall-, CBN-, Keramik- und Polykristalline Wendepplatten.

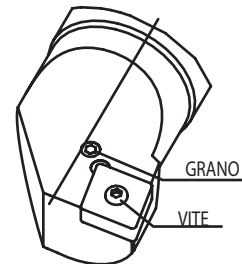
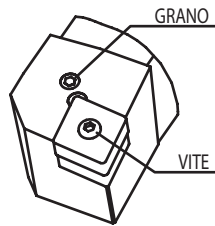

Vorgang zur Wendeplattenspannung:

1. Lockern Sie die Befestigungsschraube
2. Nehmen Sie die Schraube
3. Stellen Sie die Wendepplatte auf den Sitz.
4. Montieren Sie und ziehen Sie die Schraube fest.
5. Spannen Sie die Befestigungsschraube

Zum Ersatz der Wendepplatte verwenden Sie den umgekehrten Vorgang.



VLV-BLOCK SYSTEM®

VLV FOR INSERTS OF BIG DIMENSIONS

The VLV-Block clamping system is similar to the traditional top/screw double-clamping. The advantage is the use of a simple screw instead of a top clamping, assuring a stable clamping and an effective removal of turning.

This flexible system allows, on the same tool, the use of:

Hardmetal, CBN, polycrystalline and ceramic inserts with hole.

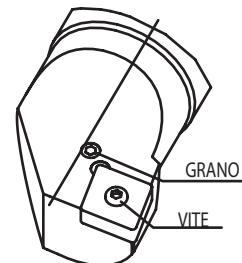
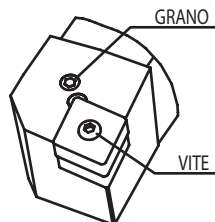

Procedure to clamp the insert:

1. Loose the locking screw
2. Remove the screw
3. Put the insert in the seat
4. Insert the screw and tighten
5. Clamp the locking screw

To replace the insert use the opposite procedure.

VLV-BLOCK SYSTEM®

СИСТЕМА VLV ДЛЯ КРЕПЛЕНИЯ ПЛАСТИН БОЛЬШИХ РАЗМЕРОВ

Система VLV похожа на стандартную систему крепления пластины винтом и прихватом сверху. Преимущество метода VLV – это использование обычного винта вместо прихвата, обеспечивающее стабильный зажим и эффективный процесс резания.

Эта гибкая система позволяет использовать в одной и той же державке следующие виды пластин:

Твердосплавные, CBN (Кубический Нитрид Бора), поликристаллические и керамические пластины с отверстием.

Процесс установки пластины:

1. Ослабьте стопорный винт (GRANO)
2. Открутите винт пластины (VITE)
3. Вставьте пластину в гнездо
4. Вставьте винт и закрутите
5. Закрутите стопорный винт

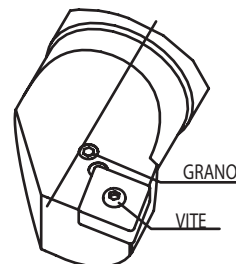
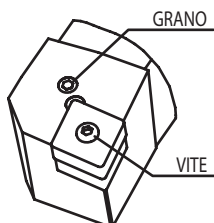

Для демонтажа пластины выполните обратные действия.

VLV-BLOCK SYSTEM®

VLV POUR PLAQUETTES DES GRANDES DIMENSIONS

La fixation VLV-BLOCK System ressemble le traditionnel system de fixation bride/levier. L'avantage est l'utilisation d'une vis, à la place d'un bride, qui garantit la même rigidité de serrage et un enlèvement matière important.

Il s'agit d'un system flexible qui permet sur le même outil l'utilisation des suivantes plaquettes: Hardmetal, CBN, céramiques et polycristallines.

Méthode de fixation des plaquettes:

1. Dévisser la vis de serrage
2. Lever la vis
3. Monter la plaquette sur le sièges
4. Insérer la vis et visser
5. Serrer la vis de serrage

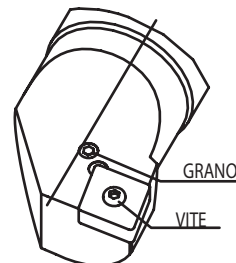
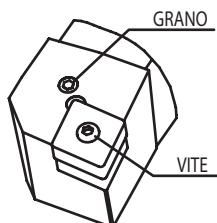

Pour le remplacement de la plaquette suivre le méthode inverse.

VLV-BLOCK SYSTEM®

VLV PER INSERTI DI GRANDI DIMENSIONI

Il bloccaggio VLV-BLOCK System e' equivalente al tradizionale doppio-bloccaggio di tipo leva-staffa.

Il vantaggio sta nella sostituzione della staffa, che puo' risultare ingombrante, con una semplice vite che, oltre a garantire la stessa rigidita' di bloccaggio, non intralcia l'evacuazione del truciolo.

Sono sistemi flessibili che permettono, sullo stesso utensile, l'utilizzo di:

inserti in metallo duro, CBN, ceramici con foro, policristallino.

Procedimento per fissare l'inserto:

1. Allentare il grano
2. Togliere la vite
3. Posizionare l'inserto nella sede
3. Inserire la vite e stringere leggermente
5. Serrare il grano

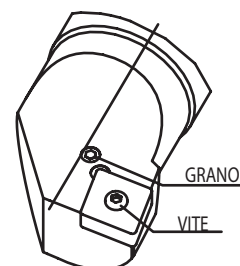
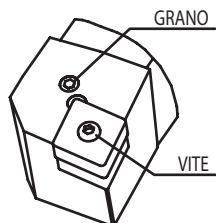

Per la sostituzione dell'inserto eseguire il procedimento inverso



VCLN

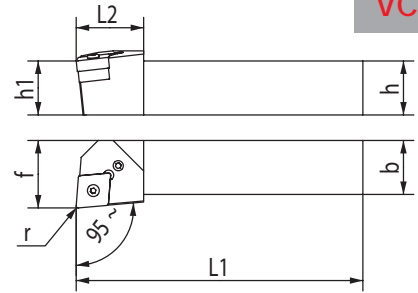
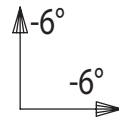

Code N.	h	h1	b	L1	L2	f	r	Inserts N.
---------	---	----	---	----	----	---	---	------------

VCLNR/L 3232 P19-VLV	32	32	32	170	42	40	1.2	CN..1906..
VCLNR/L 4040 S19-VLV	40	40	40	250	50	50	1.2	CN..1906..
VCLNR/L 4040 S25-VLV	40	40	40	250	50	50	2.4	CN..2509..
VCLNR/L 5050 T25-VLV	50	50	50	300	50	60	2.4	CN..2509..
VCLNR/L 4040 S31-VLV	40	40	40	250	60	50	2.4	CN..3109..
VCLNR/L 5050 T31-VLV	50	50	50	300	60	60	2.4	CN..3109..

Support pad	Shim pin	Lever	Screw	Screw	Wrench	Screw
K-A2	K-D2	K-LE8	K-VL8	K-VLG8	3	K-VS8
K-A2	K-D2	K-LE8	K-VL8	K-VLG8	3	K-VS8
K-Y3	K-D4	K-LE9	K-VL9	K-VLG9	3	K-SE9
K-Y3	K-D4	K-LE9	K-VL9	K-VLG9	3	K-SE9
K-A15	K-D4	K-LE10	K-VL10	K-VLG10	3	K-SE10
K-A15	K-D4	K-LE10	K-VL10	K-VLG10	3	K-SE10

VCBN

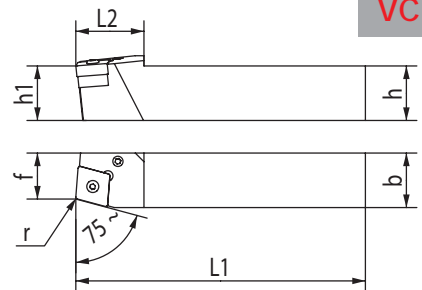
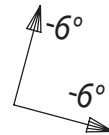

Code N.	h	h1	b	L1	L2	f	r	Inserts N.
---------	---	----	---	----	----	---	---	------------

VCBNR/L 3232 P19-VLV	32	32	32	170	42	27	1.2	CN..1906..
VCBNR/L 4040 S19-VLV	40	40	40	250	50	35	1.2	CN..1906..
VCBNR/L 4040 S25-VLV	40	40	40	250	50	35	2.4	CN..2509..
VCBNR/L 5050 T25-VLV	50	50	50	300	50	43	2.4	CN..2509..
VCBNR/L 4040 S31-VLV	40	40	40	250	60	44	2.4	CN..3109..
VCBNR/L 5050 T31-VLV	50	50	50	300	60	44	2.4	CN..3109..

Support pad	Shim pin	Lever	Screw	Screw	Wrench	Screw
K-A2	K-D2	K-LE8	K-VL8	K-VLG8	3	K-VS8
K-A2	K-D2	K-LE8	K-VL8	K-VLG8	3	K-VS8
K-Y3	K-D4	K-LE9	K-VL9	K-VLG9	3	K-SE9
K-Y3	K-D4	K-LE9	K-VL9	K-VLG9	3	K-SE9
K-A15	K-D4	K-LE10	K-VL10	K-VLG10	3	K-SE10
K-A15	K-D4	K-LE10	K-VL10	K-VLG10	3	K-SE10





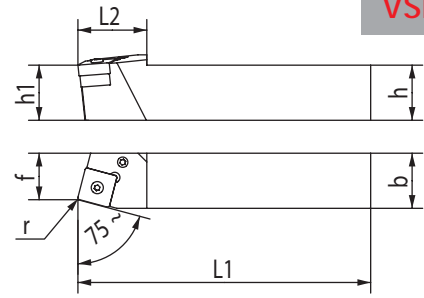
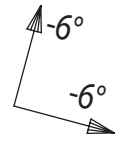



VSBN



Code N.	h	h1	b	L1	L2	f	r	Inserts N.
---------	---	----	---	----	----	---	---	------------

VSBNR/L 3232 P19-VLV	32	32	32	170	40	27	1.2	SN..1906..
VSBNR/L 4040 S19-VLV	40	40	40	250	40	35	1.2	SN..1906..
VSBNR/L 4040 S25-VLV	40	40	40	250	50	35	2.4	SN..2509..
VSBNR/L 5050 T25-VLV	50	50	50	300	50	43	2.4	SN..2509..
VSBNR/L 4040 S31-VLV	40	40	40	250	60	44	2.4	SN..3109..
VSBNR/L 5050 T31-VLV	50	50	50	300	60	44	2.4	SN..3109..





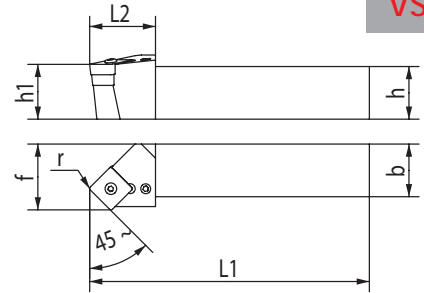
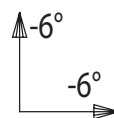

Support pad	Shim pin	Lever	Screw	Screw	Wrench	Screw
						
K-A5	K-D2	K-LE8	K-VL8	K-VLG8	3	K-VS8
K-A5	K-D2	K-LE8	K-VL8	K-VLG8	3	K-VS8
K-Y8	K-D4	K-LE9	K-VL9	K-VLG9	3	K-SE9
K-Y8	K-D4	K-LE9	K-VL9	K-VLG9	3	K-SE9
K-A14	K-D4	K-LE10	K-VL10	K-VLG10	3	K-SE10
K-A14	K-D4	K-LE10	K-VL10	K-VLG10	3	K-SE10

VSSN



Code N.	h	h1	b	L1	L2	f	r	Inserts N.
---------	---	----	---	----	----	---	---	------------

VSSNR/L 3232 P19-VLV	32	32	32	170	42	40	1.2	SN..1906..
VSSNR/L 4040 S19-VLV	40	40	40	250	50	50	1.2	SN..1906..
VSSNR/L 4040 S25-VLV	40	40	40	250	50	50	2.4	SN..2509..
VSSNR/L 5050 T25-VLV	50	50	50	300	50	60	2.4	SN..2509..

Support pad	Shim pin	Lever	Screw	Screw	Wrench	Screw
						
K-A5	K-D2	K-LE8	K-VL8	K-VLG8	3	K-VS8
K-A5	K-D2	K-LE8	K-VL8	K-VLG8	3	K-VS8
K-Y8	K-D4	K-LE9	K-VL9	K-VLG9	3	K-SE9
K-Y8	K-D4	K-LE9	K-VL9	K-VLG9	3	K-SE9



KINTEK DREHWERKZEUGE

TECHNISCHE DATEN

ISO5610 - Aussenbearbeitung

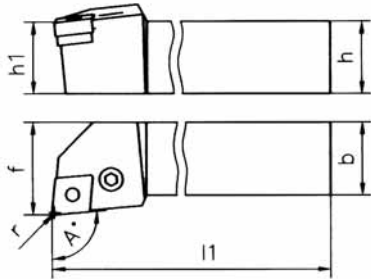

ISO5609 - Innenbearbeitung

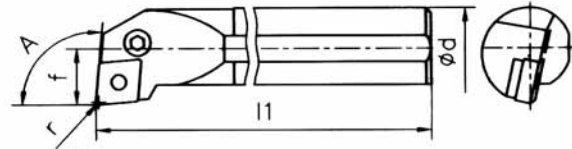

TOLERANZEN

- h: h13
- b: h13
- d: g7
- f: +0/+0,5 (Aussenbearbeitung)
- f: -0/-0,25 (Innenbearbeitung)
- l1: k16
- h1: js13

- 1 Die Klemmhalter und Bohrstangen werden aus Vergütungsstahl hergestellt, Harte 43 HRC.
- 2 Der Kopf der HM-Bohrstangen wird auch aus Vergütungsstahl produziert.
- 3 Die Auflagefläche aller Drehwerkzeuge ist geschliffen

Innenkreis der WSPlatte	6,35	7,94	9,525	12,7	15,875	19,05	25,4
Radius r	0,4		0,8		1,2		2,4



PORTE OUTILS DE TOURNAGE KINTEK

DONNEES TECHNIQUES

ISO5610 - A usage externe

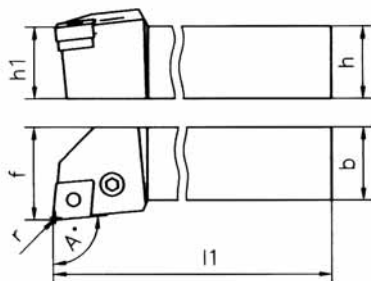

ISO5609 - A usage interieur

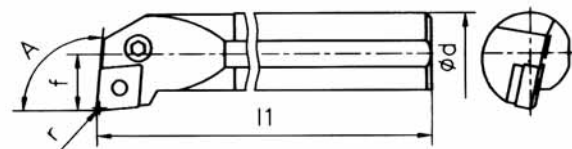

TOLERANCE

- h: h13
- b: h13
- d: g7
- f: +0/+0,5 (à usage externe)
- f: -0/-0,25 (à usage interieur)
- l1: k16
- h1: js13

- 1 Le matériel utilisé pour les outils à usage externe et à usage interieur est: acier bonifié, dureté 43 HRC.
- 2 La tête des outils en carbure est fait en acier bonifié.
- 3 La partie plate des porte outils de tournage à usage externe est rectifié.

Cercle inscrit de la plaquette	6,35	7,94	9,525	12,7	15,875	19,05	25,4
Rayon r	0,4		0,8		1,2		2,4

KINTEK TURNING TOOLS

TECHNICAL DATAS



ISO5610 - External turning tools

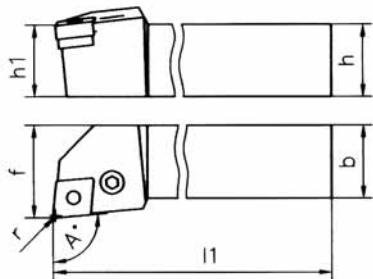

ISO5609 - Internal turning tools

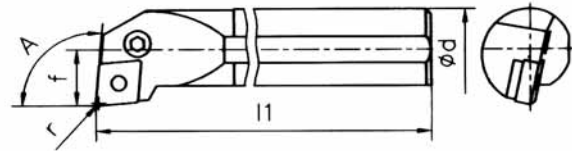

TOLERANCE

- h: h13
- b: h13
- d: g7
- f: +0/+0,5 (External)
- f: -0/-0,25 (Internal)
- l1: k16
- h1: js13

- 1 Turning tools for external and internal machining are produced of hardened steel with an hardness of 43 HRC.
- 2 The head of HM-Boring bars is made of hardened steel.
- 3 The face of turning tools for external is ground.

Inscribed circle of the insert	6,35	7,94	9,525	12,7	15,875	19,05	25,4
Radius r	0,4		0,8		1,2		2,4

UTENSILI DI TORNITURA KINTEK

DATI TECNICI



ISO5610 - Per esterni

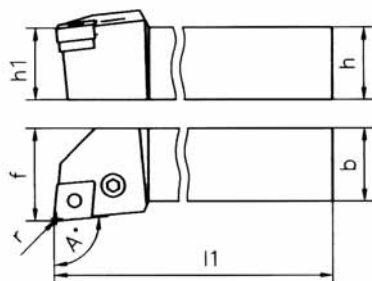

ISO5609 - Per interni

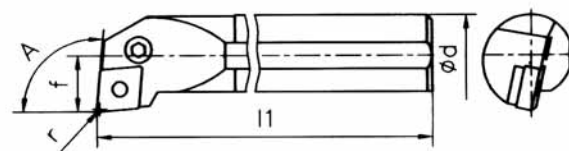

TOLLERANZE

- h: h13
- b: h13
- d: g7
- f: +0/+0,5 (per esterni)
- f: -0/-0,25 (per interni)
- l1: k16
- h1: js13

- 1 Il materiale degli utensili per interni ed esterni è: acciaio bonificato, durezza 43 HRC.
- 2 La testa degli utensili in metallo duro è in acciaio bonificato.
- 3 Il piano di appoggio degli utensili per esterni è rettificato.

Cerchio inscritto dell'inserto	6,35	7,94	9,525	12,7	15,875	19,05	25,4
Raggio r	0,4		0,8		1,2		2,4



BEZEICHNUNG VON KLEMMHALTERN FÜR DIE AUSSENBEARBEITUNG
IDENTIFICATION OF THE EXTERNAL (O.D.) TURNING TOOLS

DESIGNATION DES PORTE-PLAQUETTES EXTERIEURES
IDENTIFICAZIONE DEI PORTA INSERTI PER ESTERNI

① M
Spannsystem
Clamping system
Système de serrage
Sistema di bloccaggio

② W
Plattenform
Insert Shape
Forme des plaquettes
Forma degli inserti

③ L
Austellwinkel
Shape of turning tools
Forme des porte-plaquettes
Forma dei portainseriti

90°	75°	90°	45°	60°	90°	90°	107.5°	93°	75°	95°
A	B	C	D	E	F	G	H	J	K	L
50°	63°	117.5°	15°	75°	45°	60°	93°	72.5°	60°	85°
M	N	P	Q	R	S	T	U	V	W	Y

④ N
Freiwinkel
Clearance angle
Angle de dépouil
Angolo di spoglio

M **W** **L** **N** **R** **25** **25** **M** **08**

① ② ③ ④ ⑤ ⑥ ⑦ ⑧ ⑨

⑤ R
Vorshubrictung
Feeding direction
Sens de l'avance
Senso di avanzamento

⑥ 25
Schaffhöhe
Shank height
Hauteur des porte-plaquettes
Altezza portainserito

⑦ 25
Schaffbreite
Shank width
Largeur des porte-plaquettes
Larghezza portainserito





⑧ M
Werkzeuglänge
Total length
Longueur totale
Lunghezza totale

⑨ 08
Schneidkantenlänge
Insert cutting edge length
Longueur des arêtes des plaquettes
Lunghezza del profilo inserto

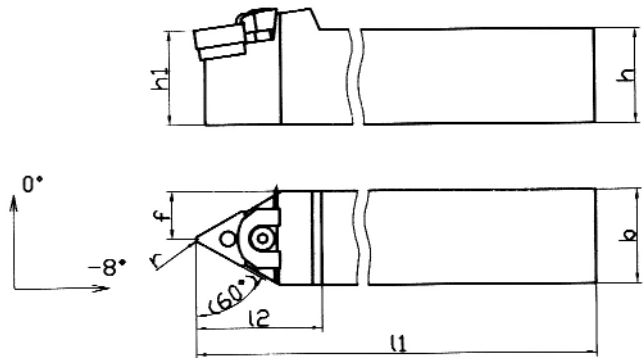
H (mm)		H (mm)	
A	32	M	150
B	40	N	160
C	50	P	170
D	60	Q	180
E	70	R	200
F	80	S	250
G	90	T	300
H	100	U	350
J	110	V	400
K	125	W	450
L	140	Y	500
		Z	600





MTEN

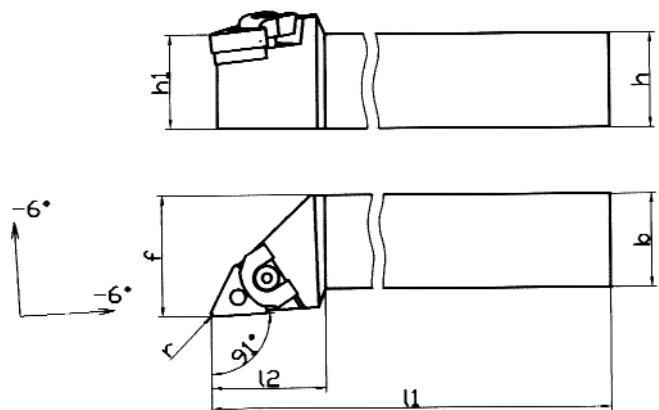

Code N.	h	b	l1	l2	h1	f	r	Inserts N.	Support pad	Clamp	Pin	Screw
												
MTENN 2525M16	25	25	150	33	25	12.5	0.8	TN..1604..	MSPTN16	STF02	PER02	VT14
MTENN 3225P16	32	25	170	33	32	12.5	0.8	TN..1604..	MSPTN16	STF02	PER02	VT14
MTENN 3232P16	32	32	170	33	32	16	0.8	TN..1604..	MSPTN16	STF02	PER02	VT14
MTENN 2525M22	25	25	150	35	25	12.5	0.8	TN..2204..	MSPTN22	STF04	PER03	VT16
MTENN 3225P22	32	25	170	35	32	12.5	0.8	TN..2204..	MSPTN22	STF04	PER03	VT16
MTENN 3232P22	32	32	170	35	32	16	0.8	TN..2204..	MSPTN22	STF04	PER03	VT16

MTGN



Code N.	h	b	l1	l2	h1	f	r	Inserts N.	Support pad	Clamp	Pin	Screw
												
MTGNR/L 2525M22	25	25	150	35	25	32	0.8	TN..2204..	MSPTN22	STF04	PER03	VT16
MTGNR/L 3225P22	32	25	170	35	32	32	0.8	TN..2204..	MSPTN22	STF04	PER03	VT16
MTGNR/L 3232P22	32	32	170	35	32	40	0.8	TN..2204..	MSPTN22	STF04	PER03	VT16

MTJN

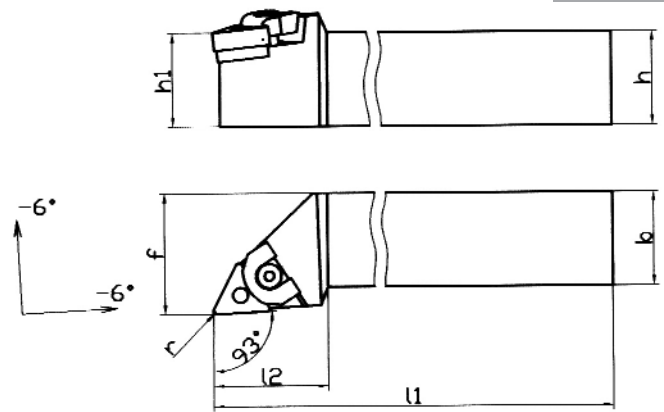

Code N.	h	b	l1	l2	h1	f	r	Inserts N.	Support pad	Clamp	Pin	Screw
MTJNR/L 2020K16	20	20	125	30	20	25	0.8	TN..1604..				
MTJNR/L 2525M16	25	25	150	30	25	32	0.8	TN..1604..				
MTJNR/L 3225P16	32	25	170	30	32	32	0.8	TN..1604..				
MTJNR/L 2525M22	25	25	150	35	25	32	0.8	TN..2204..				
MTJNR/L 3225P22	32	25	170	35	32	32	0.8	TN..2204..				
MTJNR/L 3232P22	32	32	170	35	32	40	0.8	TN..2204..				
MTJNR/L 4025M22	40	25	150	39	40	32	0.8	TN..2204..				

MWLN

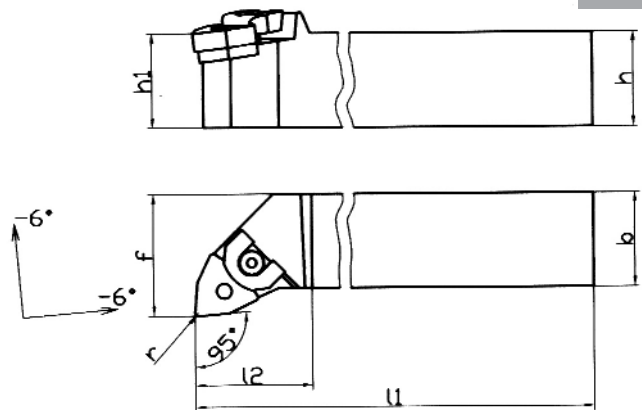

Code N.	h	b	l1	l2	h1	f	r	Inserts N.	Support pad	Clamp	Pin	Screw
MWLN/L 2020K08	20	20	125	31	20	25	0.8	WN..0804..				
MWLN/L 2525M08	25	25	150	31	25	32	0.8	WN..0804..				
MWLN/L 3225P08	32	25	170	31	32	32	0.8	WN..0804..				
MWLN/L 3232P08	32	32	170	31	32	40	0.8	WN..0804..				

PCBN

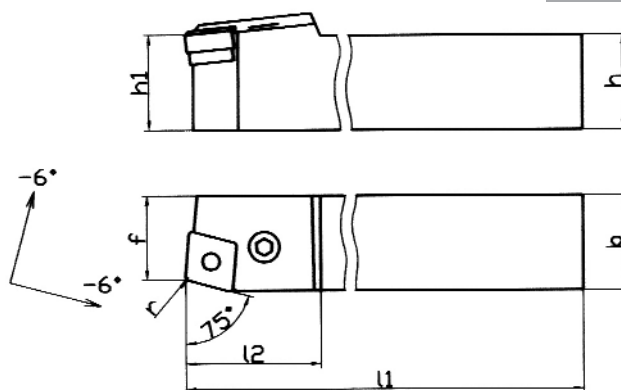

Code N.	h	b	l1	l2	h1	f	r	Inserts N.	Support pad	Shim pin	Lever	Screw
PCBNR/L 2020K12	20	20	125	29	20	17	0.8	CNM.1204..				
PCBNR/L 2525M12	25	25	150	37	25	22	0.8	CNM.1204..				
PCBNR/L 3225P12	32	25	170	37	32	22	0.8	CNM.1204..				
PCBNR/L 2525M16	25	25	150	37	25	22	1.2	CNM.1606..				
PCBNR/L 3225P16	32	25	170	37	32	22	1.2	CNM.1606..				
PCBNR/L 3232P16	32	32	170	43	32	27	1.2	CNM.1606..				
PCBNR/L 3232P19	32	32	170	43	32	27	1.2	CNM.1906..				
PCBNR/L 4040S19	40	40	250	41	40	35	1.2	CNM.1906..				

PCKN

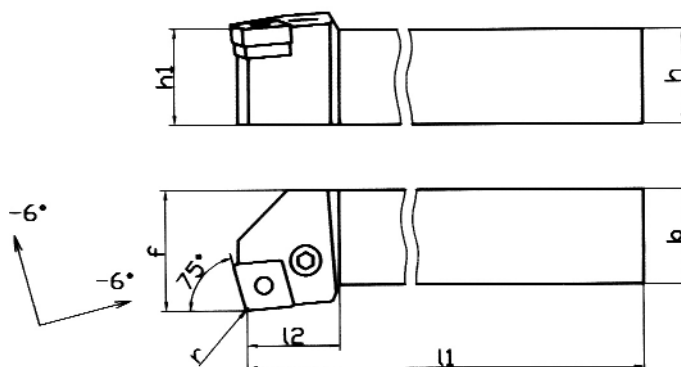

Code N.	h	b	l1	l2	h1	f	r	Inserts N.	Support pad	Shim pin	Lever	Screw
PCKNR/L 2020K12	20	20	125	24	20	25	0.8	CNM.1204..				
PCKNR/L 2525M12	25	25	150	26	25	32	0.8	CNM.1204..				
PCKNR/L 3225P12	32	25	170	35	32	32	0.8	CNM.1204..				
PCKNR/L 3225P16	32	25	170	35	32	32	1.2	CNM.1606..				
PCKNR/L 3225P19	32	25	170	35	32	32	1.2	CNM.1906..				
PCKNR/L 3232P19	32	32	170	35	32	40	1.2	CNM.1906..				
PCKNR/L 4040S19	40	40	250	35	40	50	1.2	CNM.1906..				



PCLN

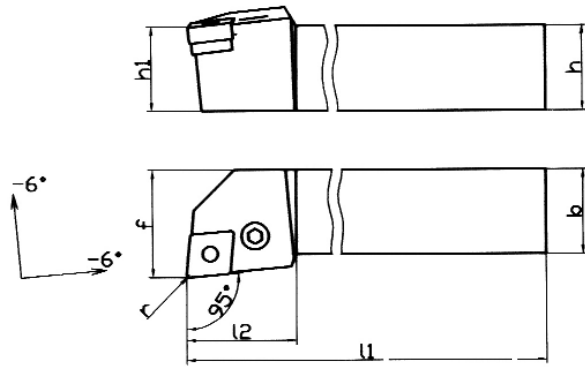

Code N.	h	b	l1	l2	h1	f	r	Inserts N.	Support pad	Shim pin	Lever	Screw
PCLNR/L 1616H12	16	16	100	26	16	20	0.8	CNM.1204..				
PCLNR/L 2020K12	20	20	125	28	20	25	0.8	CNM.1204..				
PCLNR/L 2525M12	25	25	150	33	25	32	0.8	CNM.1204..				
PCLNR/L 3225P12	32	25	170	33	32	32	0.8	CNM.1204..				
PCLNR/L 2525M16	25	25	150	33	25	32	1.2	CNM.1606..				
PCLNR/L 3225P16	32	25	170	33	32	32	1.2	CNM.1606..				
PCLNR/L 3232P16	32	32	170	39	32	40	1.2	CNM.1606..				
PCLNR/L 4040S16	40	40	250	39	40	50	1.2	CNM.1606..				
PCLNR/L 2525M19	25	25	150	39	25	32	1.2	CNM.1906..				
PCLNR/L 3225P19	32	25	170	39	32	32	1.2	CNM.1906..				
PCLNR/L 3232P19	32	32	170	39	32	40	1.2	CNM.1906..				
PCLNR/L 4040S19	40	40	250	39	40	50	1.2	CNM.1906..				



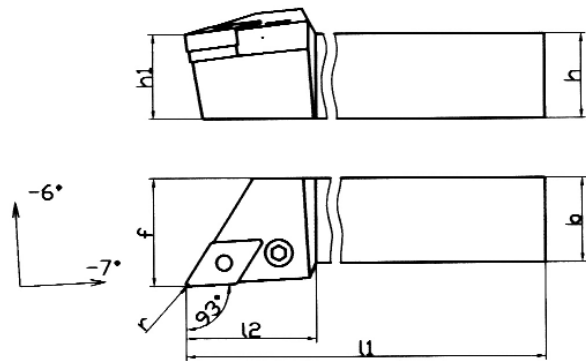

PDJN

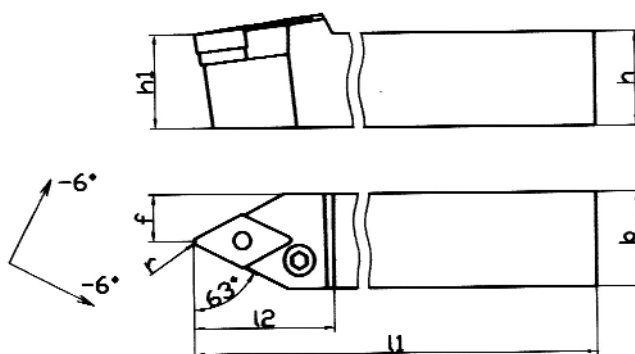

Code N.	h	b	l1	l2	h1	f	r	Inserts N.	Support pad	Shim pin	Lever	Screw
PDJNR/L 2020K15	20	20	125	35	20	25	0.8	DNM.1506..				
PDJNR/L 2525M15	25	25	150	39	25	32	0.8	DNM.1506..				
PDJNR/L 3225P15	32	25	170	33	32	32	0.8	DNM.1506..				
PDJNR/L 3232P15	32	32	170	39	32	40	0.8	DNM.1506..				
PDJNR/L 4025R15	40	25	200	39	40	32	0.8	DNM.1506..				





PDNN

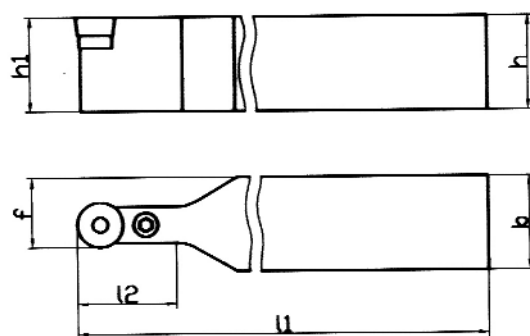

Code N.	h	b	l1	l2	h1	f	r	Inserts N.	Support pad	Shim pin	Lever	Screw
												
PDNNR/L 2020K15	20	20	125	37	20	10	0.8	DNM.1506..	SPDN15	SP02	LV05	VT05
PDNNR/L 2525M15	25	25	150	37	25	12.5	0.8	DNM.1506..	SPDN15	SP02	LV05	VT05
PDNNR/L 3225P15	32	25	170	37	32	12.5	0.8	DNM.1506..	SPDN15	SP02	LV05	VT05
PDNNR/L 4025M15	40	25	150	37	40	12.5	0.8	DNM.1506..	SPDN15	SP02	LV05	VT05
PDNNR/L 5032P15	50	32	170	36	50	16	0.8	DNM.1506..	SPDN15	SP02	LV05	VT05

PRDC



Code N.	h	b	l1	l2	h1	f	Inserts N.	Support pad	Shim pin	Lever	Screw
											
PRDCN 2020K10	20	20	125	21	20	15	RCM.100300.	SPRC10	SP01	LV07	VT07
PRDCN 2525M10	25	25	150	21	25	17.5	RCM.100300.	SPRC10	SP01	LV07	VT07
PRDCN 2525M12	25	25	150	26	25	18.5	RCM.120400.	SPRC12	SP01	LV08	VT01
PRDCN 3225Q12	32	25	180	26	32	18.5	RCM.120400.	SPRC12	SP01	LV08	VT01
PRDCN 3225Q16	32	25	180	31	32	20.5	RCM.160600.	SPRC16	SP07	LV10	VT08
PRDCN 3232P20	32	32	170	36	32	26	RCM.200600.	SPRC20	SP03	LV09	VT09

PSDN

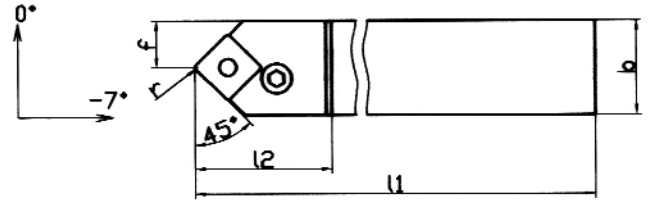
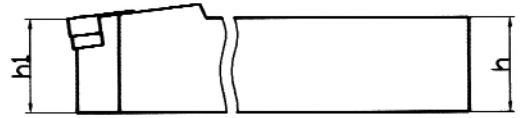

Code N.	h	b	l1	l2	h1	f	r	Inserts N.	Support pad	Shim pin	Lever	Screw
PSDNN 2020K12	20	20	125	29	20	10	0.8	SNM.1204..				
PSDNN 2525M12	25	25	150	37	25	12.5	0.8	SNM.1204..				
PSDNN 3232P19	32	32	170	43	32	16	1.2	SNM.1906..				

PSSN

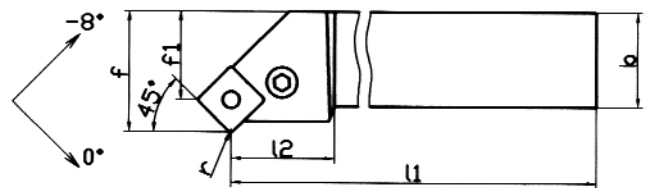
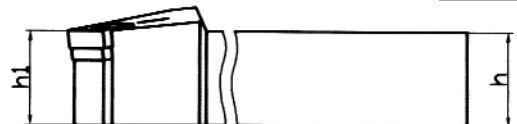

Code N.	h	b	l1	l2	h1	f	f1	r	Inserts N.	Support pad	Shim pin	Lever	Screw
PSSNR/L 2020K12	20	20	125	22	20	25	17	0.8	SNM.1204..				
PSSNR/L 2525M12	25	25	150	25	25	32	24	0.8	SNM.1204..				
PSSNR/L 2525M15	25	25	150	25	25	32	21	1.2	SNM.1506..				
PSSNR/L 3232P15	32	32	170	25	32	40	24	1.2	SNM.1506..				
PSSNR/L 3232P19	32	32	170	29	32	40	26	1.2	SNM.1906..				
PSSNR/L 4040S19	40	40	250	29	40	50	40	1.2	SNM.1906..				

PWLN

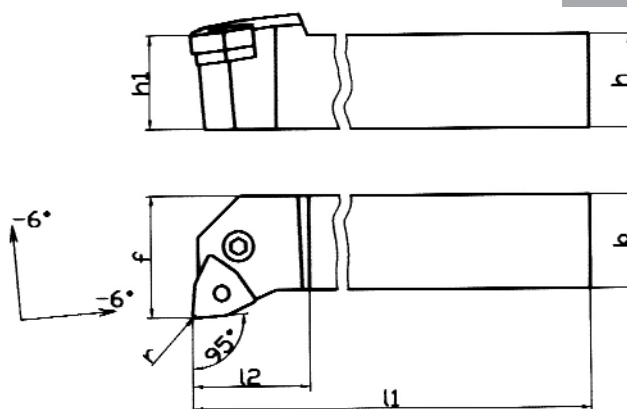

Code N.	h	b	l1	l2	h1	f	r	Inserts N.	Support pad	Shim pin	Lever	Screw
PWLN/L 2020K08	20	20	125	28	20	25	0.8	WN..0804..				
PWLN/L 2525M08	25	25	150	33	25	32	0.8	WN..0804..				
PWLN/L 3225P08	32	25	170	33	32	32	0.8	WN..0804..				

SCLC

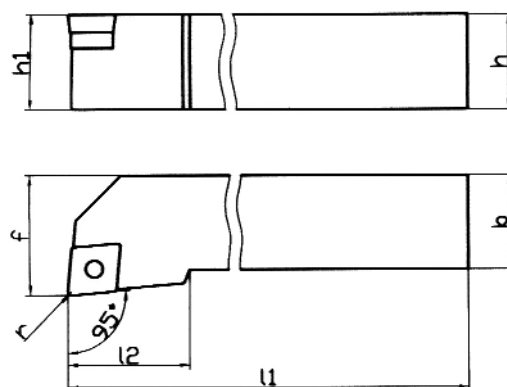

Code N.	h	b	l1	l2	h1	f	r	Inserts N.	Support pad	Bush	Screw
SCLCR/L 1212F09	12	12	80	29	12	16	0.8	CC..09T3..			
SCLCR/L 1616H09	16	16	100	29	16	20	0.8	CC..09T3..			
SCLCR/L 2020K09	20	20	125	29	20	25	0.8	CC..09T3..			
SCLCR/L 1616H12	16	16	100	29	16	20	0.8	CC..1204..			
SCLCR/L 2020K12	20	20	125	29	20	25	0.8	CC..1204..			
SCLCR/L 2525M12	25	25	150	33	25	32	0.8	CC..1204..			

SDJC

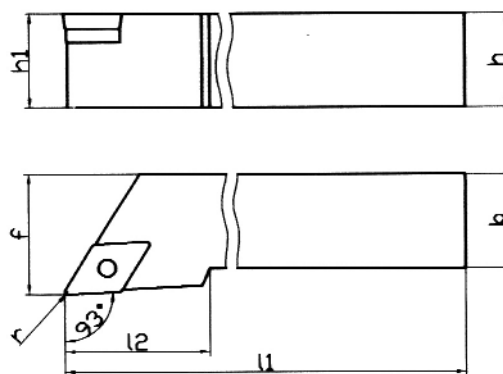

Code N.	h	b	l1	l2	h1	f	r	Inserts N.	Support pad	Bush	Screw
SDJCR/L 1212F11	12	12	80	29	12	16	0.8	DC..11T3..	-	-	TR14
SDJCR/L 1616H11	16	16	100	29	16	20	0.8	DC..11T3..	SPDC11	VTA02	TR8
SDJCR/L 2020K11	20	20	125	29	20	25	0.8	DC..11T3..	SPDC11	VTA02	TR8
SDJCR/L 2525M11	25	25	150	33	25	32	0.8	DC..11T3..	SPDC11	VTA02	TR8

SDNC

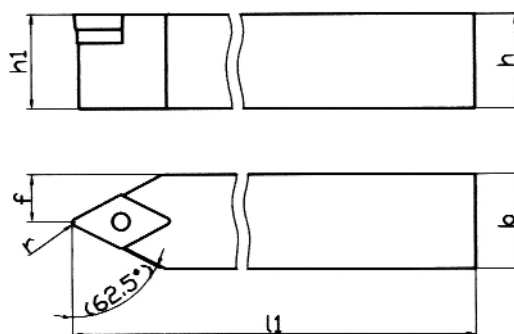

Code N.	h	b	l1	h1	f	r	Inserts N.	Support pad	Bush	Screw
SDNCN 1616H11	16	16	100	16	8	0.8	DC..11T3..	SPDC11	VTA02	TR8
SDNCN 2020K11	20	20	125	20	10	0.8	DC..11T3..	SPDC11	VTA02	TR8
SDNCN 2525M11	25	25	150	25	12.5	0.8	DC..11T3..	SPDC11	VTA02	TR8



SSDC

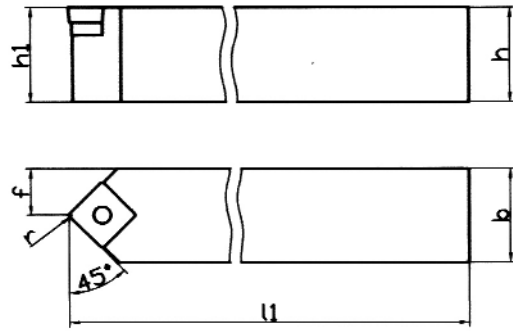

Code N.	h	b	l1	h1	f	r	Inserts N.	Support pad	Bush	Screw
SSDCN 1212F09	12	12	80	12	6	0.8	SCM.09T3..		-	TR14
SSDCN 1616H09	16	16	100	16	8	0.8	SCM.09T3..	SPSC09	VTA02	TR8
SSDCN 2020K12	20	20	125	20	10	0.8	SCM.1204..	SPSC12	VTA01	TR4
SSDCN 2525M12	25	25	150	25	12.5	0.8	SCM.1204..	SPSC12	VTA01	TR4

SVJB

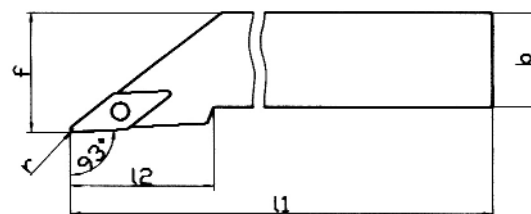
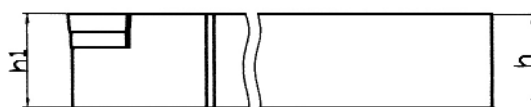

Code N.	h	b	l1	l2	h1	f	r	Inserts N.	Support pad	Bush	Screw
SVJBR/L 1616H11	16	16	100	29	16	20	0.4	VB..1102..	-	-	TR1
SVJBR/L 2020K11	20	20	125	29	20	25	0.4	VB..1102..	-	-	TR1
SVJBR/L 2525M11	25	25	150	29	25	32	0.4	VB..1102..	-	-	TR1
SVJBR/L 2020K16	20	20	125	35	20	25	0.8	VB..1604..	SPVC16	VTA02	TR8
SVJBR/L 2525M16	25	25	150	35	25	32	0.8	VB..1604..	SPVC16	VTA02	TR8
SVJBR/L 3225P16	32	25	170	35	32	32	0.8	VB..1604..	SPVC16	VTA02	TR8

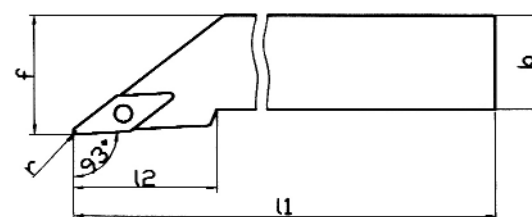
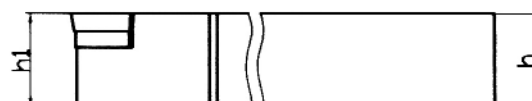

SVJC



Code N.	h	b	l1	l2	h1	f	r	Inserts N.	Support pad	Bush	Screw
SVJCR/L 1212F11	12	12	80	23	12	16	0.4	VC..1103..	-	-	TR1
SVJCR/L 1616H11	16	16	100	23	16	20	0.4	VC..1103..	-	-	TR1
SVJCR/L 2020K11	20	20	125	23	20	25	0.4	VC..1103..	-	-	TR1
SVJCR/L 2525M11	25	25	150	26	25	32	0.4	VC..1103..	-	-	TR1
SVJCR/L 1212F16	12	12	80	29	12	16	0.8	VC..1604..	-	-	TR14
SVJCR/L 1616H16	16	16	100	34	16	20	0.8	VC..1604..	SPVC16	VTA02	TR8
SVJCR/L 2020K16	20	20	125	34	20	25	0.8	VC..1604..	SPVC16	VTA02	TR8
SVJCR/L 2525M16	25	25	150	35	25	32	0.8	VC..1604..	SPVC16	VTA02	TR8
SVJCR/L 3225P16	32	25	170	35	32	32	0.8	VC..1604..	SPVC16	VTA02	TR8

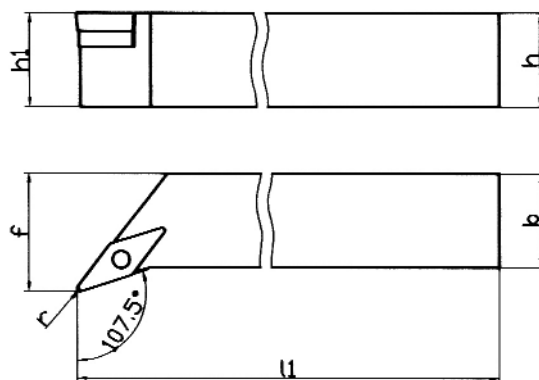

SVHB



Code N.	h	b	l1	h1	f	r	Inserts N.	Support pad	Bush	Screw
										
SVHBR/L 2020K16	20	20	125	20	25	0.8	VB..1604..	SPVC16	VTA02	TR8
SVHBR/L 2525M16	25	25	150	25	32	0.8	VB..1604..	SPVC16	VTA02	TR8
SVHBR/L 3225P16	32	25	170	32	32	0.8	VB..1604..	SPVC16	VTA02	TR8

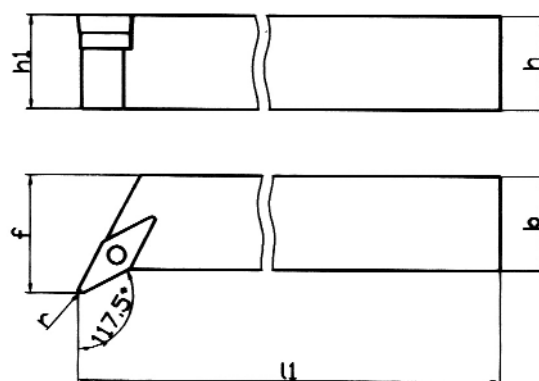

SVPB



Code N.	h	b	l1	h1	f	r	Inserts N.	Support pad	Bush	Screw
										
SVPBR/L 2020K16	20	20	125	20	25	0.8	VB..1604..	SPVC16	VTA02	TR8
SVPBR/L 2525M16	25	25	150	25	32	0.8	VB..1604..	SPVC16	VTA02	TR8
SVPBR/L 3225P16	32	25	170	32	32	0.8	VB..1604..	SPVC16	VTA02	TR8

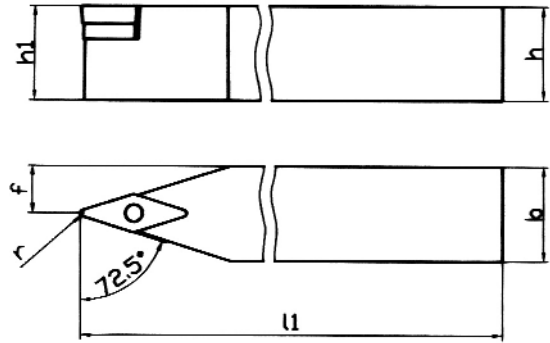

SVVB

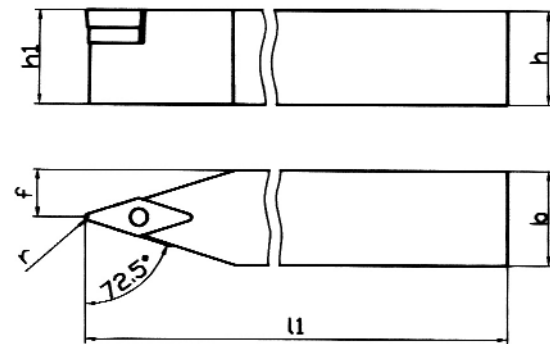

Code N.	h	b	l1	h1	f	r	Inserts N.	Support pad	Bush	Screw
										
SVVBN 2020K16	20	20	125	20	10	0.8	VB..1604..	SPVC16	VTA02	TR8
SVVBN 2525M16	25	25	150	25	12.5	0.8	VB..1604..	SPVC16	VTA02	TR8
SVVBN 3225P16	32	25	170	32	12.5	0.8	VB..1604..	SPVC16	VTA02	TR8

SVVC



Code N.	h	b	l1	h1	f	r	Inserts N.	Support pad	Bush	Screw
										
SVVCN 2020K16	20	20	125	20	10	0.8	VC..1604..	SPVC16	VTA02	TR8
SVVCN 2525M16	25	25	150	25	12.5	0.8	VC..1604..	SPVC16	VTA02	TR8
SVVCN 3225P16	32	25	170	32	12.5	0.8	VC..1604..	SPVC16	VTA02	TR8

BEZEICHNUNG VON KLEMMHALTERN FÜR INNENBEARBEITUNG DESIGNATION DES BARRES D'ALEPAGE INTERIEURES
 IDENTIFICATION OF THE INTERNAL (I.D.) BORING TOOLS IDENTIFICAZIONE DEI BARENI PER INTERNI
 СИСТЕМА ОБОЗНАЧЕНИЯ РАСТОЧНЫХ ДЕРЖАВОК

① **S**

Konstruktion
Construction
Construction
Costruzione

A	Tool holder with oil hole Stell shank
C	Carbide shank
E	Tool holder with oil hole Carbide shank
S	Stell shank

② **25**

Klemmhälterdurchmesser
Turning tools diameter
Diamètre des porte-plaquettes
Diametro dei porta inserti



08	Ø8
10	Ø10
12	Ø12
16	Ø16
20	Ø20
25	Ø25
32	Ø32
40	Ø40
50	Ø50

③ **T**

Werkzeuglänge
Total length
Longueur totale
Lunghezza totale

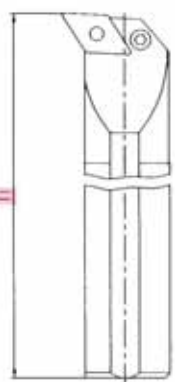

l (mm)	
F	80
H	100
K	125
M	150
P	170
Q	180
R	200
X	225
S	250
T	300
U	350
V	400
W	450
Z	600

④ **P**

Spannsystem
Clamping system
Système de serrage
Sistema di bloccaggio

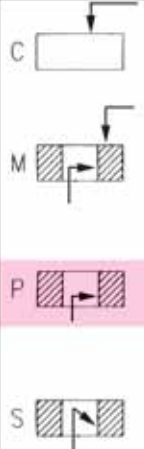

C	[Diagram]
M	[Diagram]
P	[Diagram]
S	[Diagram]



⑤ **D**

Plattform
Insert Shape
Forme des plaquettes
Forma degli inserti

C	80°
D	55°
S	[Diagram]
T	[Diagram]
V	35°
W	80°

⑥ **U**

Austellwinkel
Shape of turning tools
Forme des porte-plaquettes
Forma dei portainseriti

90°	[Diagram]	F
75°	[Diagram]	K
95°	[Diagram]	L
117.5°	[Diagram]	P
107.5°	[Diagram]	Q
93°	[Diagram]	U

⑦ **N**

Freiwinkel
Clearance angle
Angle de dépouil
Angolo di spoglia

B	5°
C	T°
N	0°
P	11°

⑧ **R**

Vorhubrichtung
Freeding direction
Sens de l'avance
Senso di avanzamento

R	[Diagram]
L	[Diagram]
N	[Diagram]

⑨ **11**

Schneidkantenlänge
Insert cutting edge length
Longueur des arêtes des plaquettes
Lunghezza del profilo inserto

11	[Diagram]
S	[Diagram]
I	[Diagram]
T	[Diagram]
W	[Diagram]

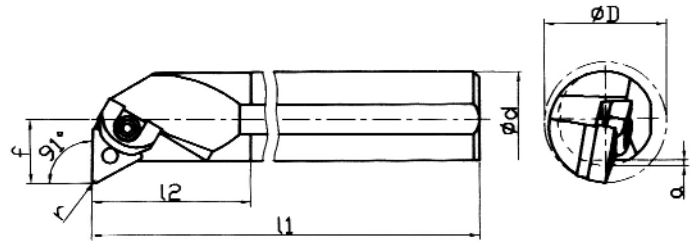
MTFN

Code N.	d	l1	l2	f	a	K°	D	r	Inserts N.	Support pad	Clamp	Pin	Screw
S32TMTFNR/L16	32	300	55	22	2	-12	40	0.8	TN..1604..				
S40UMTFNR/L16	40	350	55	27	2	-10	50	0.8	TN..1604..	MSPTN16	STF01	PER02	VT14
S50WMTFNR/L16	50	450	70	35	2	-10	63	0.8	TN..1604..	MSPTN16	STF01	PER02	VT14
S32TMTFNR/L22	32	300	55	22	2	-10	40	0.8	TN..2204..	MSPTN22	STF04	PER03	VT16
S40UMTFNR/L22	40	350	63	27	2	-10	50	0.8	TN..2204..	MSPTN22	STF04	PER03	VT16
S50WMTFNR/L22	50	450	70	35	2	-10	63	0.8	TN..2204..	MSPTN22	STF04	PER03	VT16

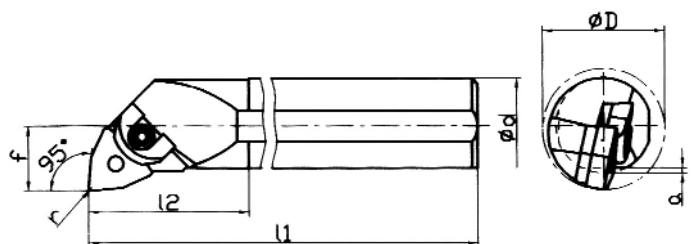
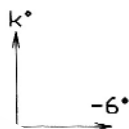
MWLN

Code N.	d	l1	l2	f	a	K°	D	r	Inserts N.	Support pad	Clamp	Pin
S25SMWLN/L08	25	250	42	17	2	-12	32	0.8	WN..0804..			
S32UMWLN/L08	32	350	49	22	2	-12	40	0.8	WN..0804..	-	STF10	PER08
S40VMWLN/L08	40	400	56	27	2	-10	50	0.8	WN..0804..	MSPWN08	STF10	PER08
S50WMWLN/L08	50	450	63	35	2	-10	63	0.8	WN..0804..	MSPWN08	STF10	PER08

PCLN

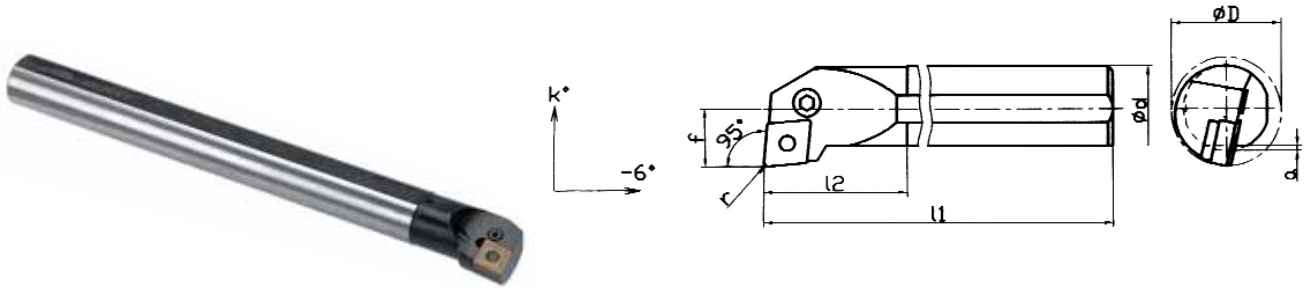

Code N.	d	l1	l2	f	a	K°	D	r	Inserts N.	Support pad	Shim pin	Lever	Screw
A32SPCLNR/L12 ◦	32	250	50	22	-	-10	40	0.8	CNM..1204..				
A40TPCLNR/L12 ◦	40	300	60	27	-	-10	50	0.8	CNM..1204..	SPCN12	SP02	LV02	VT02
S25TPCLNR/L12	25	300	45	17	2	-12	32	0.8	CNM..1204..	-	-	LV11	VT10
S32UPCLNR/L12	32	350	50	22	2	-10	40	0.8	CNM..1204..	SPCN12	SP02	LV02	VT02
S40VPCLNR/L12	40	400	60	27	2	-10	50	0.8	CNM..1204..	SPCN12	SP02	LV02	VT02
S40VPCLNR/L16	40	400	60	27	2	-10	50	1.2	CNM..1606..	SPCN16	SP03	LV03	VT03
S50WPCLNR/L16	50	450	75	35	2	- 8	63	1.2	CNM..1606..	SPCN16	SP03	LV03	VT03
S50WPCLNR/L19	50	450	75	35	2	- 8	63	1.2	CNM..1906..	SPCN19	SP04	LV04	VT04

◦ : Mit Kühlmittelzufuhr - With oil hole
 Avec trou pour refrigerant - Con foro per refrigerante
 С отверстием для СОЖ

PDUN

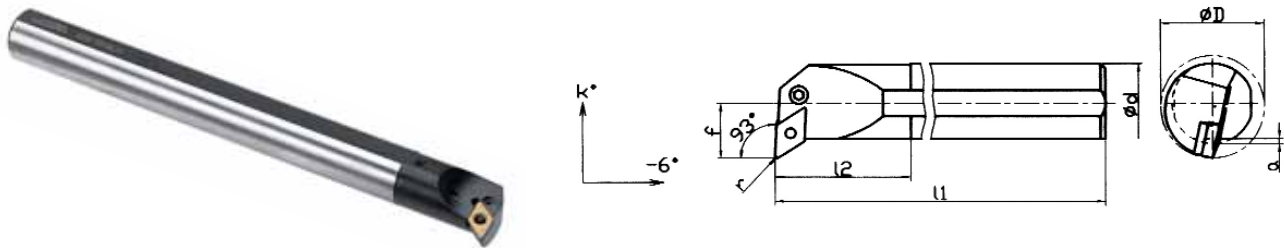

Code N.	d	l1	l2	f	a	K°	D	r	Inserts N.	Support pad	Shim pin	Lever	Screw
A32SPDUNR/L15 ◦	32	250	60	22	-	-15	40	0.8	DN..1506..				
A40TPDUNR/L15 ◦	40	300	60	27	-	-12	50	0.8	DN..1506..	SPDN15	SP02	LV05	VT05
S32UPDUNR/L15	32	350	60	22	2	-15	40	0.8	DN..1506..	SPDN15	SP02	LV05	VT05
S40VPDUNR/L15	40	400	60	27	2	-12	50	0.8	DN..1506..	SPDN15	SP02	LV05	VT05
S50WPDUNR/L15	50	450	70	35	2	- 8	63	0.8	DN..1506..	SPDN15	SP02	LV05	VT05

◦ : Mit Kühlmittelzufuhr - With oil hole
 Avec trou pour refrigerant - Con foro per refrigerante
 С отверстием для СОЖ

PSKN

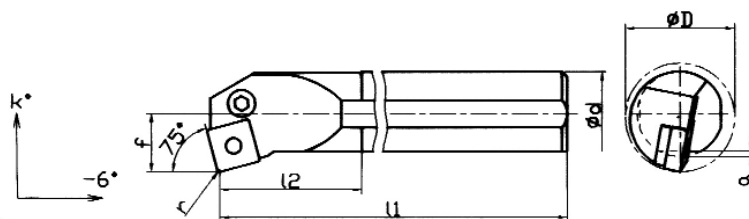

Code N.	d	l1	l2	f	a	K°	D	r	Inserts N.	Support pad	Shim pin	Lever	Screw
A32SPSKNR/L12	32	250	57	22	-	-10	40	0.8	SN..1204..	SPSN12	SP02	LV02	VT02
A40TPSKNR/L12	40	300	57	27	-	-10	50	0.8	SN..1204..	SPSN12	SP02	LV02	VT02
S32UPSKNR/L12	32	350	57	22	2	-10	40	0.8	SN..1204..	SPSN12	SP02	LV02	VT02
S40VPSKNR/L12	40	400	57	27	2	-10	50	0.8	SN..1204..	SPSN12	SP02	LV02	VT02
S40VPSKNR/L15	40	400	57	27	2	-10	50	1.2	SN..1506..	SPSN15	SP03	LV03	VT03
S50WPSKNR/L15	50	450	70	35	2	-10	63	1.2	SN..1506..	SPSN15	SP03	LV03	VT03
S50WPSKNR/L19	50	450	70	35	2	-10	63	1.2	SN..1906..	SPSN19	SP09	LV04	VT04

- : Mit Kühlmittelzufuhr - With oil hole
Avec trou pour refrigerant - Con foro per refrigerante
С отверстием для СОЖ

SCLC

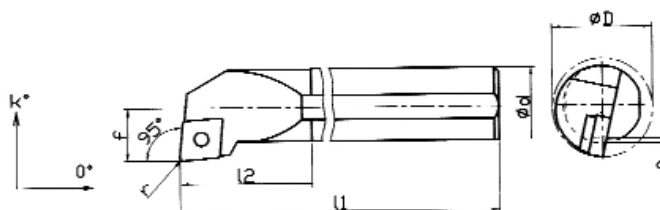

Code N.	d	l1	l2	f	a	K°	D	r	Inserts N.	Support pad	Bush	Screw
S08HSCLCR/L06	8	100	25	6	0.5	-12	11	0.4	CC..0602..	-	-	TR1
S10KSCLCR/L06	10	125	25	7	0.5	-10	13	0.4	CC..0602..	-	-	TR1
S12MSCLCR/L06	12	150	30	9	0.5	-10	16	0.4	CC..0602..	-	-	TR1
S16RSCLCR/L06	16	200	40	11	1	-10	20	0.4	CC..0602..	-	-	TR1
S16RSCLCR/L09	16	200	40	11	1	-10	20	0.8	CC..09T3..	-	-	TR12
S20SSCLCR/L09	20	250	40	13	1.5	-8	25	0.8	CC..09T3..	-	-	TR14
S25TSCLCR/L12	25	300	50	17	2	-5	32	0.8	CC..1204..	-	-	TR13
S32USCLCR/L12	32	350	60	22	2	-5	40	0.8	CC..1204..	SPCC12	VTA01	TR4
S40VSCLCR/L12	40	400	60	27	2	-5	50	0.8	CC..1204..	SPCC12	VTA01	TR4

- : Mit Kühlmittelzufuhr - With oil hole
Avec trou pour refrigerant - Con foro per refrigerante
С отверстием для СОЖ

SDUC

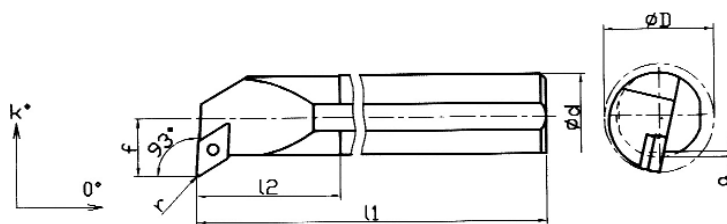

Code N.	d	l1	l2	f	a	K°	D	r	Inserts N.	Support pad	Bush	Screw
S10KSDUCR/L07	10	125	25	7	0.5	-10	13	0.4	DC..0702..			TR1
S12MSDUCR/L07	12	150	25	9	0.5	-10	16	0.4	DC..0702..	-	-	TR1
S16RSDUCR/L07	16	200	40	11	1	-10	20	0.4	DC..0702..	-	-	TR1
S20SSDUCR/L11	20	250	40	13	1.5	- 8	25	0.8	DC..11T3..	-	-	TR12
S25TSDUCR/L11	25	300	45	17	2	- 5	32	0.8	DC..11T3..	-	-	TR14
S32USDUCR/L11	32	350	60	22	2	- 5	40	0.8	DC..11T3..	SPDC11	VTA02	TR8

- : Mit Kühlmittelzufuhr - *With oil hole*
Avec trou pour refrigerant - *Con foro per refrigerante*
С отверстием для СОЖ

STFC

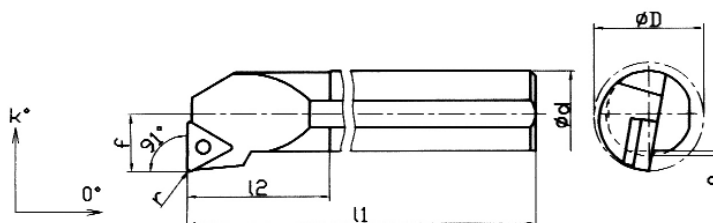

Code N.	d	l1	l2	f	a	K°	D	r	Inserts N.	Support pad	Bush	Screw
S10KSTFCR/L09	10	125	25	7	0.5	-12	13	0.4	TC..0902..			TR6
S10KSTFCR/L11	10	125	28	7	0.5	-12	13	0.4	TC..1102..	-	-	TR1
S16RSTFCR/L11	16	200	40	11	1	- 8	20	0.4	TC..1102..	-	-	TR1
S20SSTFCR/L16	20	250	45	13	1.5	- 8	25	0.8	TC..16T3..	-	-	TR14
S25TSTFCR/L16	25	300	50	17	2	- 5	32	0.8	TC..16T3..	-	-	TR14
S32USTFCR/L16	32	350	50	22	2	- 5	40	0.8	TC..16T3..	SPTC16	VTA02	TR8
S40VSTFCR/L16	40	400	60	27	2	- 5	50	0.8	TC..16T3..	SPTC16	VTA02	TR8

- : Mit Kühlmittelzufuhr - *With oil hole*
Avec trou pour refrigerant - *Con foro per refrigerante*
С отверстием для СОЖ





Die in diesem Katalog angegebenen Abmessungen können ohne Voranzeige an den Kunden geändert werden.

Les dimensions et les mesures sur ce catalogue peuvent être changées à n'importe quel moment sans l'obligation de renseigner les clients.

Tool dimensions and tool sizes on this catalogue could be changed in every moment without duty to advice customer.

Le dimensioni e le misure riportate in questo catalogo possono essere variate in qualsiasi momento senza obbligo di darne notizia.

Размеры инструмента могут быть изменены без предварительного уведомления.

stampa
la grafica - cantù